

Elementary Particles II

3 – Flavor Physics and CP Violation

Quark Mixing – CKM – K^0 Strangeness oscillations
CP violation – Extension to Bottom and Charm
FCNC and Physics Beyond the Standard Model

Quark Mixing - I

Reminder:

Fermi constant from μ decay \simeq Fermi constant from β decay

Tiny difference:

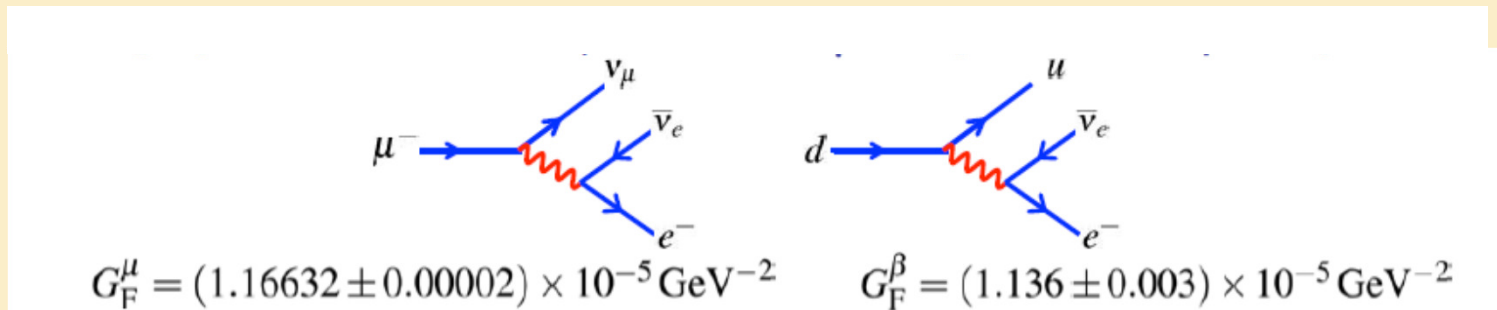

Kaon decay suppressed by a factor ~ 20 as compared to π decay

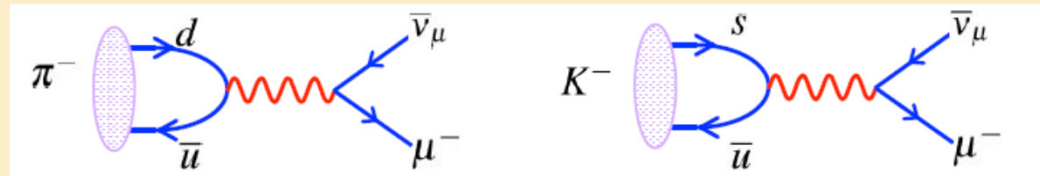

Quark Mixing - II

Cabibbo explanation:

Weak eigenstates

Strong (mass) eigenstates

$$\begin{pmatrix} d' \\ s' \end{pmatrix} = \begin{pmatrix} \cos \theta_c & \sin \theta_c \\ -\sin \theta_c & \cos \theta_c \end{pmatrix} \begin{pmatrix} d \\ s \end{pmatrix}$$

Weak charged currents: Linear combinations of different flavors

$$\theta_c \approx 13.1^\circ$$

Unique value for Cabibbo angle explaining many strange particle decays

Strong support for universality of weak interaction

Quark Mixing - III

Another mystery

$$BR(K^0 \rightarrow \mu^+ \mu^-) \sim 10^{-8} BR(K^+ \rightarrow \mu^+ \nu_\mu)$$

GIM explanation:

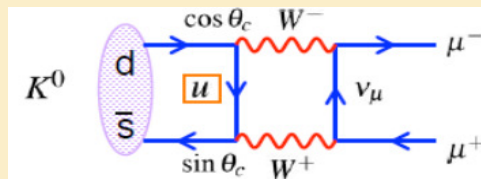
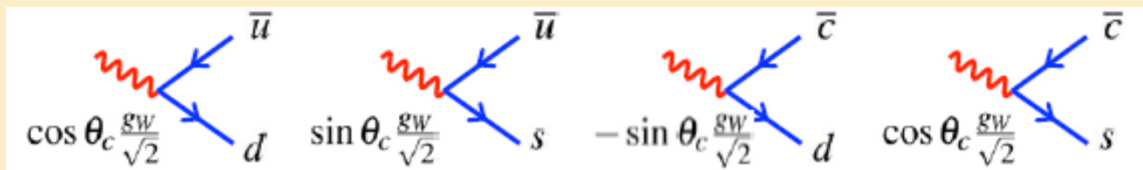

$$M_1 \propto g_W^4 \cos \theta_c \sin \theta_c$$

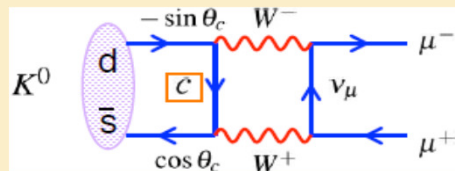

$$M_2 \propto -g_W^4 \cos \theta_c \sin \theta_c$$

Tiny BR left due to $m_c \neq m_u$ in the virtual quark propagator

Quark Mixing - IV

Extend mixing to 3 families:

$$\begin{pmatrix} d' \\ s' \\ b' \end{pmatrix} = V_{(d)}^\dagger \begin{pmatrix} d \\ s \\ b \end{pmatrix} = \begin{pmatrix} V_{ud} & V_{us} & V_{ub} \\ V_{cd} & V_{cs} & V_{cb} \\ V_{td} & V_{ts} & V_{tb} \end{pmatrix} \begin{pmatrix} d \\ s \\ b \end{pmatrix}, \quad \begin{pmatrix} u' \\ c' \\ t' \end{pmatrix} = V_{(u)}^\dagger \begin{pmatrix} u \\ c \\ t \end{pmatrix}$$

→ Conventionally: Mixing of d -like quarks only

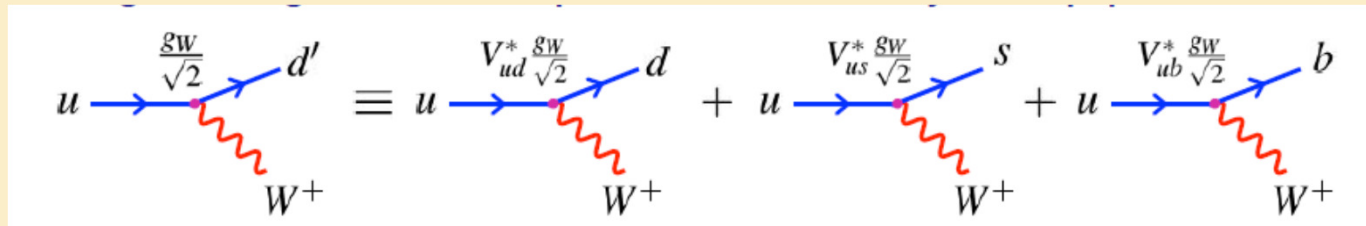

Quark Mixing - V

Encode mixing CKM matrix element into charged current

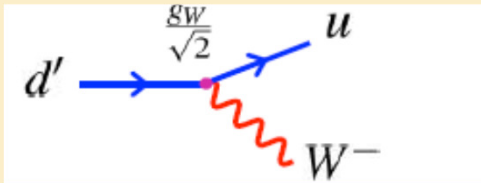

$$j_{d'u} = \bar{u} \left[-i \frac{g_W}{\sqrt{2}} \gamma^\mu \frac{1}{2} (1 - \gamma^5) \right] d'$$

$$j_{du} = \bar{u} \left[-i \frac{g_W}{\sqrt{2}} \gamma^\mu \frac{1}{2} (1 - \gamma^5) \right] V_{ud} d$$

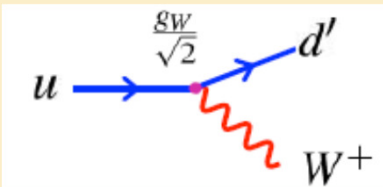

$$j_{ud'} = \bar{d}' \left[-i \frac{g_W}{\sqrt{2}} \gamma^\mu \frac{1}{2} (1 - \gamma^5) \right] u$$

$$\bar{d}' = d'^{\dagger} \gamma^0 \rightarrow (V_{ud} d)^{\dagger} \gamma^0 = V_{ud}^* d^{\dagger} \gamma^0 = V_{ud}^* \bar{d}$$

$$j_{ud} = \bar{d} V_{ud}^* \left[-i \frac{g_W}{\sqrt{2}} \gamma^\mu \frac{1}{2} (1 - \gamma^5) \right] u$$

Quark Mixing - VI

Charged current : $qq, \bar{q}\bar{q}, q\bar{q}$

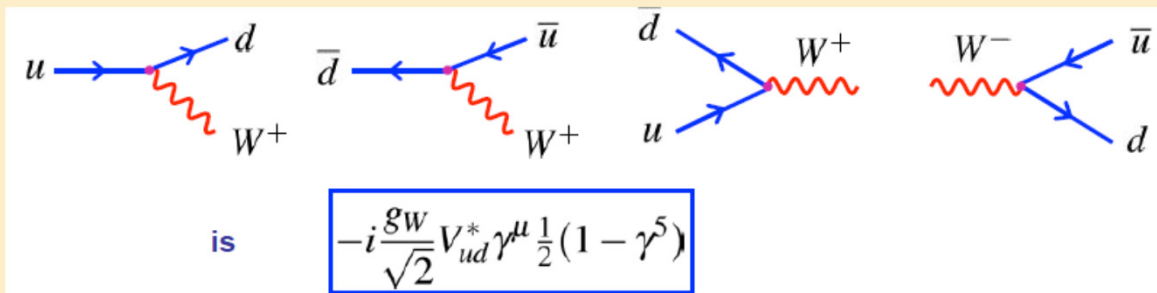
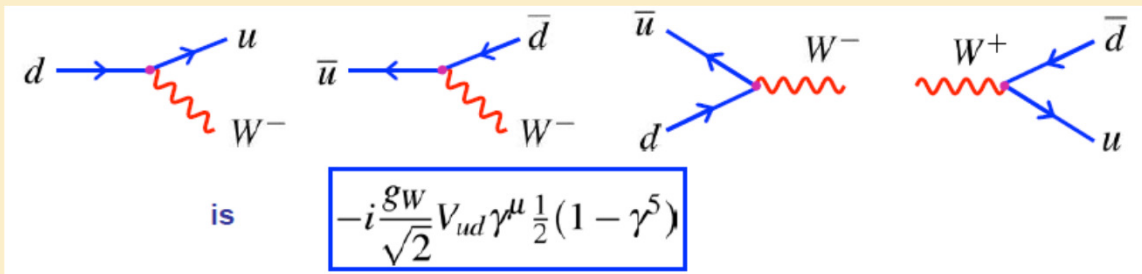

CKM - I

Generic mixing matrix:

Mixing weak eigenstates into mass eigenstates (or the opposite)

3×3 Unitary matrix:

9 complex parameters \rightarrow 18 real parameters

$$9 \text{ unitarity conditions: } \left. \begin{array}{l} UU^\dagger = 1 \\ (U^\dagger)_{ij} = U_{ji}^* \end{array} \right\} \rightarrow \sum_{j=1}^3 a_{ij} a_{jk}^* = \delta_{ik}, \quad i, k = 1, \dots, 3$$

$\rightarrow 18 - 9 = 9$ free, real parameters

CKM - II

Mixing matrix definition for 'up'- and 'down'-like quarks:

$$\begin{pmatrix} u \\ c \\ t \end{pmatrix} = V_{(u)} \begin{pmatrix} u_1' \\ u_2' \\ u_3' \end{pmatrix}; \quad \begin{pmatrix} d \\ s \\ b \end{pmatrix} = V_{(d)} \begin{pmatrix} d_1' \\ d_2' \\ d_3' \end{pmatrix}$$

$$\rightarrow \begin{pmatrix} u_1' \\ u_2' \\ u_3' \end{pmatrix} = V_{(u)}^{-1} \begin{pmatrix} u \\ c \\ t \end{pmatrix} = V_{(u)}^\dagger \begin{pmatrix} u \\ c \\ t \end{pmatrix} \rightarrow (u \quad c \quad t) = (u_1' \quad u_2' \quad u_3') (V_{(u)}^\dagger)^\dagger = (u_1' \quad u_2' \quad u_3') V_{(u)}$$

$$\rightarrow \begin{pmatrix} d_1' \\ d_2' \\ d_3' \end{pmatrix} = V_{(d)}^{-1} \begin{pmatrix} d \\ s \\ b \end{pmatrix} = V_{(d)}^\dagger \begin{pmatrix} d \\ s \\ b \end{pmatrix}$$

$$\rightarrow V_{CKM} = V_{(u)} V_{(d)}^\dagger \equiv V = \begin{pmatrix} V_{ud} & V_{us} & V_{ub} \\ V_{cd} & V_{cs} & V_{cb} \\ V_{td} & V_{ts} & V_{tb} \end{pmatrix}$$

CKM - III

Re-define (arbitrary) phases of quark mass eigenstates:

$$\begin{pmatrix} u \\ c \\ t \end{pmatrix} \rightarrow \begin{pmatrix} e^{i\varphi_u} & 0 & 0 \\ 0 & e^{i\varphi_c} & 0 \\ 0 & 0 & e^{i\varphi_t} \end{pmatrix} \begin{pmatrix} u \\ c \\ t \end{pmatrix}, \quad \begin{pmatrix} d \\ s \\ b \end{pmatrix} \rightarrow \begin{pmatrix} e^{i\varphi_d} & 0 & 0 \\ 0 & e^{i\varphi_s} & 0 \\ 0 & 0 & e^{i\varphi_b} \end{pmatrix} \begin{pmatrix} d \\ s \\ b \end{pmatrix}$$

Translate into redefinition of weak eigenstates:

$$\begin{pmatrix} u' \\ c' \\ t' \end{pmatrix} \rightarrow V_u^\dagger \begin{pmatrix} e^{i\varphi_u} & 0 & 0 \\ 0 & e^{i\varphi_c} & 0 \\ 0 & 0 & e^{i\varphi_t} \end{pmatrix} \begin{pmatrix} u \\ c \\ t \end{pmatrix}, \quad \begin{pmatrix} d' \\ s' \\ b' \end{pmatrix} \rightarrow V_d^\dagger \begin{pmatrix} e^{i\varphi_d} & 0 & 0 \\ 0 & e^{i\varphi_s} & 0 \\ 0 & 0 & e^{i\varphi_b} \end{pmatrix} \begin{pmatrix} d \\ s \\ b \end{pmatrix}$$

Redefinition of weak eigenstates equivalent to *CKM* redefinition:

$$V_{CKM} \rightarrow \begin{pmatrix} e^{-i\varphi_u} & 0 & 0 \\ 0 & e^{-i\varphi_c} & 0 \\ 0 & 0 & e^{-i\varphi_t} \end{pmatrix} V_{CKM} \begin{pmatrix} e^{i\varphi_d} & 0 & 0 \\ 0 & e^{i\varphi_s} & 0 \\ 0 & 0 & e^{i\varphi_b} \end{pmatrix} = \begin{pmatrix} V_{ud} e^{i(\varphi_d - \varphi_u)} & V_{us} e^{i(\varphi_s - \varphi_u)} & V_{ub} e^{i(\varphi_b - \varphi_u)} \\ V_{cd} e^{i(\varphi_d - \varphi_c)} & V_{cs} e^{i(\varphi_s - \varphi_c)} & V_{cb} e^{i(\varphi_b - \varphi_c)} \\ V_{td} e^{i(\varphi_d - \varphi_t)} & V_{ts} e^{i(\varphi_s - \varphi_t)} & V_{tb} e^{i(\varphi_b - \varphi_t)} \end{pmatrix}$$

CKM - IV

Factorize one (any) phase:

$$\rightarrow V_{CKM} = e^{-i\varphi_u} \begin{pmatrix} V_{ud} e^{i\varphi_d} & V_{us} e^{i\varphi_s} & V_{ub} e^{i\varphi_b} \\ V_{cd} e^{i(\varphi_u + \varphi_d - \varphi_c)} & V_{cs} e^{i(\varphi_u + \varphi_s - \varphi_c)} & V_{cb} e^{i(\varphi_u + \varphi_b - \varphi_c)} \\ V_{td} e^{i(\varphi_u + \varphi_d - \varphi_t)} & V_{ts} e^{i(\varphi_u + \varphi_s - \varphi_t)} & V_{tb} e^{i(\varphi_u + \varphi_b - \varphi_t)} \end{pmatrix}$$

Global field phase not relevant: Can't be used to fix one free V parameter

5 free relative phases

$\rightarrow 9 - 5 = 4$ real free parameters

Encode as:

3 'rotation angles' (\leftarrow Euler angles)

[In order to understand this:

Suppose the matrix is real \rightarrow Any 3×3 real, unitary matrix = Orthogonal

Any 3×3 orthogonal matrix = 3D Rotation \rightarrow 3 angles]

1 complex (irreducible) phase factor

CKM - V

→ Generally CKM matrix *must* be complex, 3x3 real would require just 3 parameters

Standard form : → Will have 5 complex V_{ij}

Parameters:

$\theta_{12}, \theta_{13}, \theta_{23}$ Rotation angles

δ Irreducible phase

$$s_{ij} = \sin \theta_{ij}$$

$$c_{ij} = \cos \theta_{ij}$$

$$V = \begin{pmatrix} c_{12}c_{13} & s_{12}c_{13} & s_{13}e^{-i\delta} \\ -s_{12}c_{23} - c_{12}s_{23}e^{+i\delta} & c_{12}c_{23} - s_{12}s_{23}s_{13}e^{+i\delta} & s_{23}c_{13} \\ s_{12}s_{23} - c_{12}c_{23}s_{13}e^{+i\delta} & -c_{12}s_{23} - s_{12}c_{23}s_{13}e^{+i\delta} & c_{13}c_{23} \end{pmatrix}$$

Experiment:

$$\sin \theta_{13} \ll \sin \theta_{23} \ll \sin \theta_{12} \ll 1$$

CKM - VI

Visualizing CKM in standard representation:

Product of 3 independent 2D rotations + 1 Phase

$$U_{12} = \begin{bmatrix} c_{12} & s_{12} & 0 \\ -s_{12} & c_{12} & 0 \\ 0 & 0 & 1 \end{bmatrix}$$

$$U_{13} = \begin{bmatrix} c_{13} & 0 & s_{13} \\ 0 & 1 & 0 \\ -s_{13} & 0 & c_{13} \end{bmatrix}$$

$$U_{23} = \begin{bmatrix} 1 & 0 & 0 \\ 0 & c_{23} & s_{23} \\ 0 & -s_{23} & c_{23} \end{bmatrix}$$

$$U_{\delta} = \begin{bmatrix} 1 & 0 & 0 \\ 0 & 1 & 0 \\ 0 & 0 & e^{-i\delta_{13}} \end{bmatrix}$$

$$V_{\text{CKM}} = U_{23}U_{\delta}^{\dagger}U_{13}U_{\delta}U_{12}$$

CKM - VII

Wolfenstein parametrization of V_{CKM} :

Based on experimental evidence of some hierarchy among angles

Define:

$$\lambda = \sin \theta_{12}$$

$$A\lambda^2 = \sin \theta_{23}$$

$$A\lambda^3(\rho - i\eta) = \sin \theta_{13}e^{-i\delta}$$

Then:

$$\cos \theta_{12} = \sqrt{1 - \lambda^2} \simeq 1 - \frac{\lambda^2}{2} - \frac{\lambda^4}{8}$$

$$\rightarrow V_{CKM} \simeq \begin{pmatrix} 1 - \frac{\lambda^2}{2} & \lambda & A\lambda^3(\rho - i\eta) \\ -\lambda & 1 - \frac{\lambda^2}{2} & A\lambda^2 \\ A\lambda^3(1 - \rho - i\eta) & -A\lambda^2 & 1 \end{pmatrix}$$

$$\lambda = 0.2259 \pm 0.0021 \approx \sin \theta_C$$

$$A = 0.82 \pm 0.02$$

$$\eta \neq 0 \rightarrow \mathcal{CP}$$

Filling CKM - I

Filling CKM (PDG 2013)

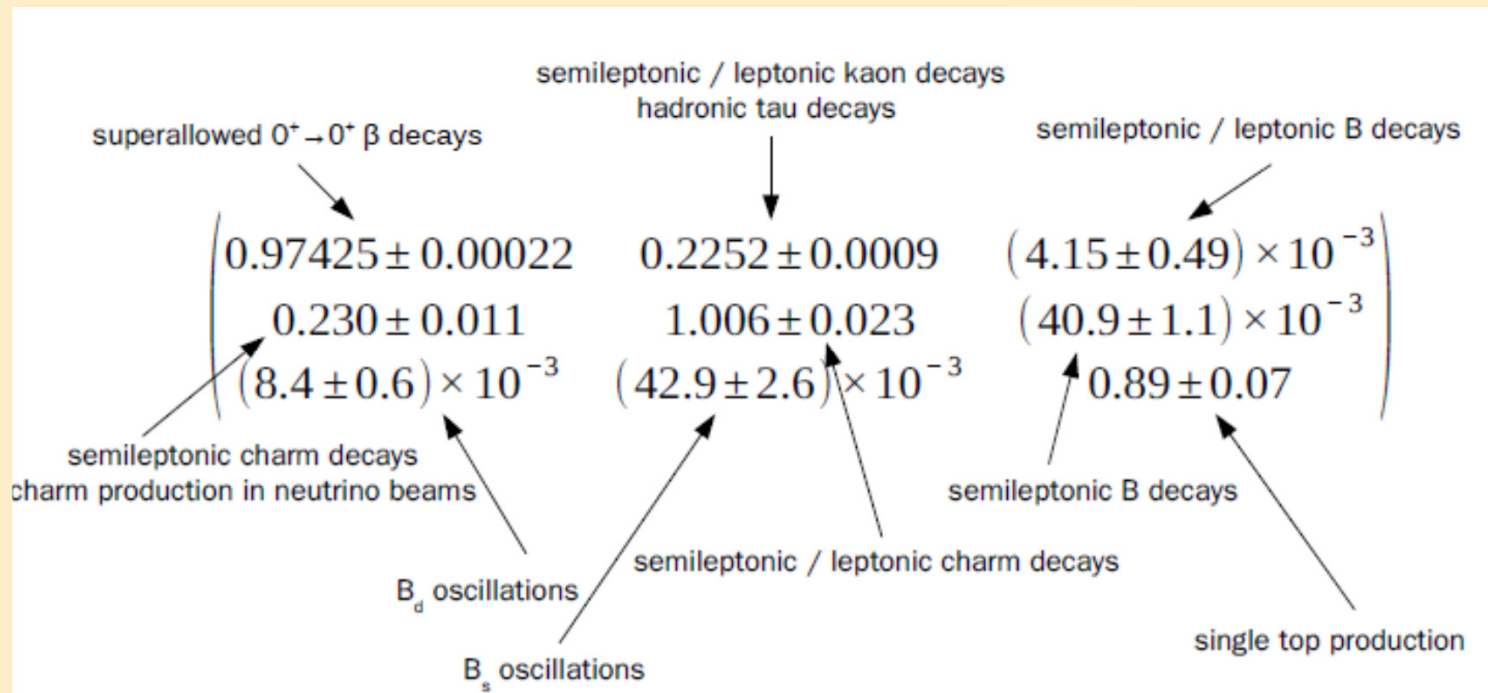

CKM elements involving t quark less well known

Filling CKM - II

$|V_{ud}|$

from nuclear beta decay

$\begin{pmatrix} \times \dots \\ \dots \\ \dots \end{pmatrix}$

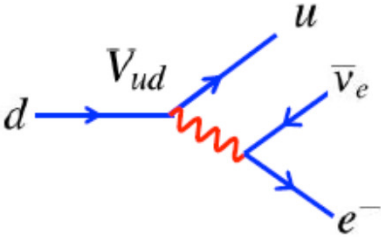

Super-allowed $0^+ \rightarrow 0^+$ beta decays are relatively free from theoretical uncertainties

$\Gamma \propto |V_{ud}|^2$

$|V_{ud}| = 0.97377 \pm 0.00027$

$(\approx \cos \theta_c)$

Superaligned β transition: $\Delta J = 0, \Delta P = 0$

+ Same level structure for both initial and final nucleus, just $n \leftrightarrow p$

Global level shift, only due to Coulomb energy \rightarrow No theoretical corrections!

Example: $n \rightarrow p + e^- + \bar{\nu}_e$

\rightarrow High precision measurement of V_{ud} from transition rate

Filling CKM - III

$|V_{us}|$

from semi-leptonic kaon decays

$\begin{pmatrix} \cdot & \times & \cdot \\ \cdot & \cdot & \cdot \\ \cdot & \cdot & \cdot \end{pmatrix}$

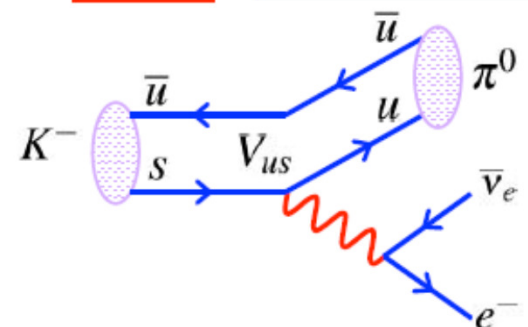

$\Gamma \propto |V_{us}|^2$

$|V_{us}| = 0.2257 \pm 0.0021$

$(\approx \sin \theta_c)$

Differential decay rate:

$$\frac{d\Gamma(\overline{K}^0 \rightarrow \pi^+ e^- \overline{\nu}_e)}{dx_\pi} = \underbrace{\frac{G_F^2 m_K^5}{192\pi^2}}_{\text{Standard 3-body total rate}} |V_{us}|^2 \underbrace{f(q^2)^2}_{\text{Form factor}} \underbrace{\left(x_\pi^2 - 4 \frac{m_\pi^2}{m_K^2}\right)^{3/2}}_{\text{Phase space factor}}, x_\pi = \frac{2E_\pi}{m_K}$$

Filling CKM - IV

$|V_{cd}|$

from neutrino scattering

$$\nu_\mu + N \rightarrow \mu^+ \mu^- X$$

$$\begin{pmatrix} \cdots \\ \times \\ \cdots \end{pmatrix}$$

Look for opposite charge di-muon events in ν_μ scattering from production and decay of a $D^+(c\bar{d})$ meson

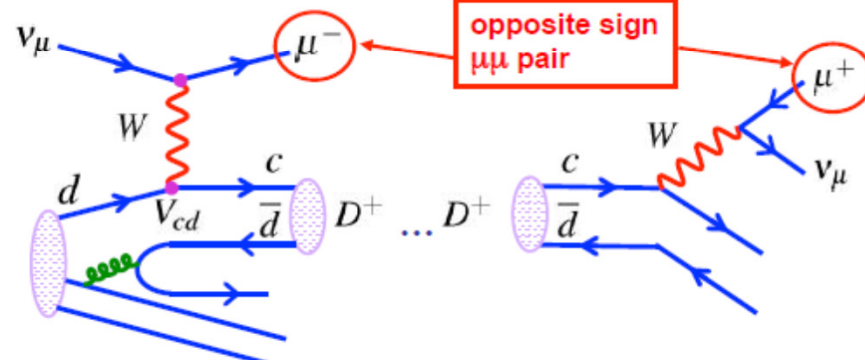

$$\text{Rate} \propto |V_{cd}|^2 \text{Br}(D^+ \rightarrow X \mu^+ \nu_\mu)$$

Measured in various collider experiments

$$\Rightarrow |V_{cd}| = 0.230 \pm 0.011$$

Filling CKM - V

$|V_{cs}|$

from semi-leptonic charmed meson decays

$\begin{pmatrix} \cdot & \cdot & \cdot \\ \cdot & \times & \cdot \\ \cdot & \cdot & \cdot \end{pmatrix}$

e.g.

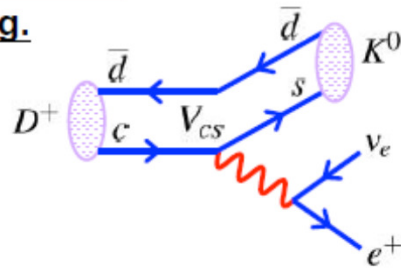

$$\Gamma \propto |V_{cs}|^2$$

• Precision limited by theoretical uncertainties

$$|V_{cs}| = 0.957 \pm 0.017 \pm 0.093$$

experimental error

theory uncertainty

Make D^+D^- pairs from $e^+e^- \rightarrow \psi(3770) \rightarrow D^+D^-$

BR $D^+ \rightarrow K^0 e^+ \nu_e = (8.83 \pm 0.22) \%$

Filling CKM - VI

$|V_{cb}|$

from semi-leptonic B hadron decays

$\begin{pmatrix} \cdots & \cdots \\ \cdots & \times \\ \cdots & \cdots \end{pmatrix}$

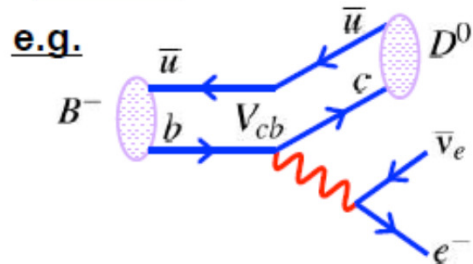

$$\Gamma \propto |V_{cb}|^2$$

$$|V_{cb}| = 0.0416 \pm 0.0006$$

$\bar{D}^0 \ell^+ \nu_\ell$

[a] (2.23 ± 0.11) %

$$\frac{d\Gamma(b \rightarrow c \ell^+ \bar{\nu}_\ell)}{dx} = \frac{G_F^2 m_b^5}{192\pi^2} |V_{cb}|^2 \left(2x^2 \left(\frac{1-x-\zeta}{1-x} \right)^2 \left(3 - 2x + \zeta + \frac{2\zeta}{1-x} \right) \right), \zeta = \frac{m_c^2}{m_b^2}, x = \frac{2E_\ell}{m_b}$$

$$L = 10^{33} \text{ cm}^{-2} \text{ s}^{-1} \rightarrow L_{\text{int}} \sim 10^{38} \text{ cm}^{-2} \text{ d}^{-1}$$

$$\sigma_{B\bar{B}} \sim 1 \text{ nb} = 10^{-33} \text{ cm}^2 \rightarrow R \sim 10^5 B\bar{B} \text{ d}^{-1}$$

$$\rightarrow R_{\text{dec}} \sim 10^3 D^0 e^+ \bar{\nu}_e \text{ d}^{-1} \rightarrow \frac{\sqrt{\sigma_{\text{stat}}}}{|V_{cb}|} \sim \frac{3\%}{\sqrt{T(\text{days})}}$$

Filling CKM - VII

$|V_{ub}|$

from semi-leptonic B hadron decays

$\begin{pmatrix} \dots & \times \\ \dots & \\ \dots & \end{pmatrix}$

e.g.

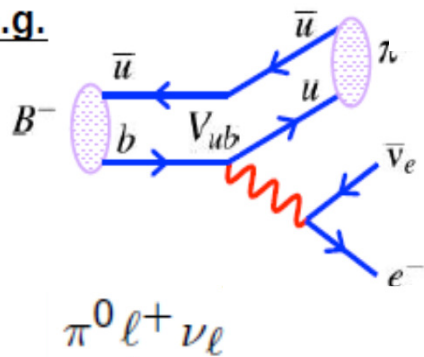

$$\Gamma \propto |V_{ub}|^2$$

$$|V_{ub}| = 0.0043 \pm 0.0003$$

$$(7.7 \pm 1.2) \times 10^{-5}$$

$$\frac{\Gamma(b \rightarrow ul^- \bar{\nu}_l)}{\Gamma(b \rightarrow cl^- \bar{\nu}_l)} = \frac{|V_{ub}|^2}{|V_{cb}|^2} \left(\frac{f(m_u^2 / m_b^2)}{f(m_c^2 / m_b^2)} \right), \text{ compare rates}$$

$$L = 10^{33} \text{ cm}^{-2} \text{ s}^{-1} \rightarrow L_{\text{int}} \sim 10^{38} \text{ cm}^{-2} \text{ d}^{-1}$$

$$\sigma_{B\bar{B}} \sim 1 \text{ nb} = 10^{-33} \text{ cm}^2 \rightarrow R \sim 10^5 B\bar{B} \text{ d}^{-1}$$

$$\rightarrow R_{\text{dec}} \sim 10 \pi^0 e^- \bar{\nu}_e \text{ d}^{-1} \rightarrow \frac{\sigma_{\text{stat}}}{|V_{ub}|} \sim \frac{30\%}{\sqrt{T(\text{days})}}$$

Filling CKM - VIII

$$|V_{tb}|$$

from single top production

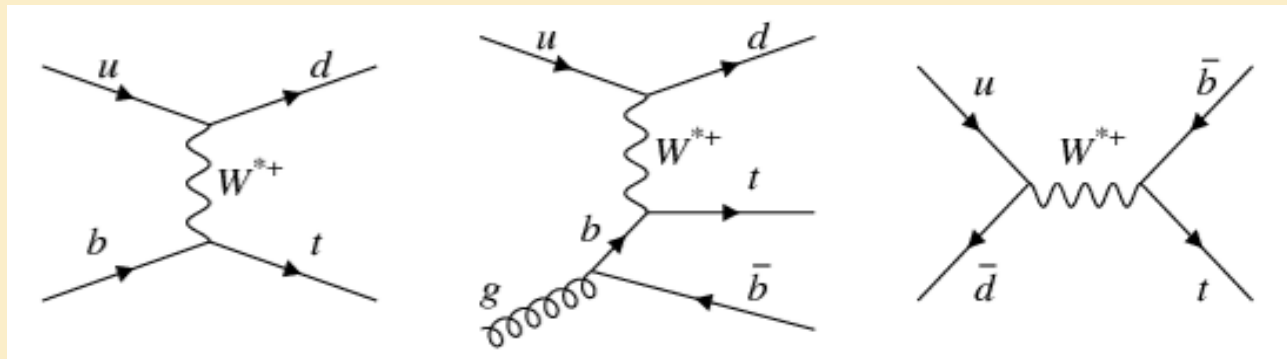

Filling CKM - IX

$$|V_{td}|, |V_{ts}|$$

from B_d, B_s oscillations

Cannot rely on direct measurements of V_{td}, V_{ts} from t decays: Too small

Rather use loop diagrams of B_d, B_s oscillations

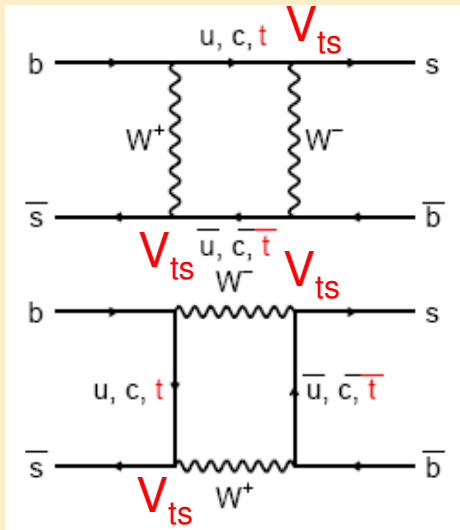

+ Similar for B_d , yielding V_{td}

CKM Triangles - I

V_{CKM} unitary: 9 unitarity conditions

Take 6 'off-diagonal' conditions:

$$(1) \quad V_{ud}V_{us}^* + V_{cd}V_{cs}^* + V_{td}V_{ts}^* = 0;$$

$$(2) \quad V_{ud}V_{ub}^* + V_{cd}V_{cb}^* + V_{td}V_{tb}^* = 0;$$

$$(3) \quad V_{us}V_{ub}^* + V_{cs}V_{cb}^* + V_{ts}V_{tb}^* = 0;$$

$$(4) \quad V_{ud}^*V_{cd} + V_{us}^*V_{cs} + V_{ub}^*V_{cb} = 0;$$

$$(5) \quad V_{ud}^*V_{td} + V_{us}^*V_{ts} + V_{ub}^*V_{tb} = 0;$$

$$(6) \quad V_{cd}^*V_{td} + V_{cs}^*V_{ts} + V_{cb}^*V_{tb} = 0;$$

Each condition:

Sum of 3 complex numbers = 0

Complex number $\hat{=}$ Vector in the complex plane

→ Each condition \sim 3 numbers should add to a closed triangle

CKM Triangles - II

Sides & Angles from experiment

Area: Same for all 6

$$A_{\text{triangle}} = \frac{1}{2} J_{CP} = \frac{1}{2} \text{Im}(V_{ij} V_{kl} V_{il}^* V_{kj}^*); \quad i \neq k, j \neq l; \text{Im}$$

$$J_{CP} = s_{12} s_{13} s_{23} c_{12} c_{13}^2 c_{23} s_{\delta_{13}} \approx A^2 \lambda^6 \eta$$

→ J_{CP} = Nice measure of \mathcal{CP}

Example: Most common unitary triangle

$$V_{ud} V_{ub}^* + V_{cd} V_{cb}^* + V_{td} V_{tb}^* = 0$$

Wolfenstein approximation:

$$A\lambda^3 \left(1 - \frac{\lambda^2}{2}\right) (\rho + i\eta) - A\lambda^3 [1 + A^2 \lambda^4 (\rho + i\eta)] + A\lambda^3 \left[1 - (\rho + i\eta) \left(1 - \frac{\lambda^2}{2}\right)\right] = 0$$

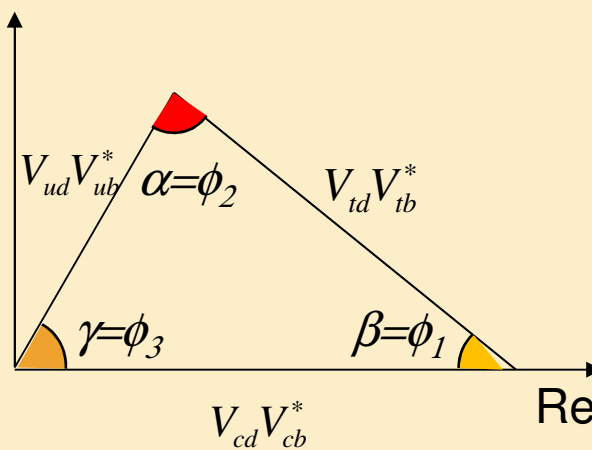

CKM Triangles - III

$$\begin{cases} V_{ud}V_{ub}^* = A\lambda^3 \left(1 - \frac{\lambda^2}{2}\right) (\rho + i\eta) \\ V_{cd}V_{cb}^* = -A\lambda^3 \\ V_{td}V_{tb}^* = A\lambda^3 [1 - (\rho + i\eta)] \end{cases}$$

Normalize to $V_{cd}V_{cb}^* = -A\lambda^3 \equiv 1$;

Ignore overall - signs

$$V_{ud}V_{ub}^* = \left(1 - \frac{\lambda^2}{2}\right) (\rho + i\eta) \approx \rho + i\eta$$

$$V_{cd}V_{cb}^* = 1$$

$$V_{td}V_{tb}^* \approx 1 - (\rho + i\eta)$$

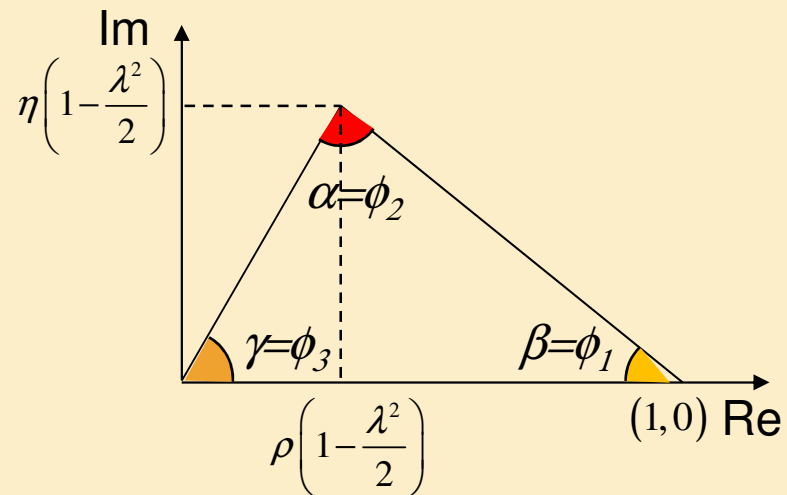

CKM Triangles - IV

Recent fit by CKMFitter group:

Observable	Central $\pm 1 \sigma$	$\pm 2 \sigma$	$\pm 3 \sigma$
A	0.812 [+0.015 -0.022]	0.812 [+0.025 -0.031]	0.812 [+0.035 -0.039]
λ	0.22543 [+0.00059 -0.00095]	0.2254 [+0.0010 -0.0019]	0.2254 [+0.0013 -0.0027]
ρ_{bar}	0.145 [+0.027 -0.027]	0.145 [+0.046 -0.040]	0.145 [+0.057 -0.050]
η_{bar}	0.343 [+0.015 -0.015]	0.343 [+0.030 -0.026]	0.343 [+0.044 -0.035]
J [10^{-5}]	2.96 [+0.18 -0.14]	2.96 [+0.32 -0.19]	2.96 [+0.46 -0.23]
α [deg]	91.1 [+4.3 -4.3]	91.1 [+7.1 -6.2]	91.1 [+8.8 -7.8]
α [deg] (meas. not in the fit)	95.9 [+2.2 -5.6]	95.9 [+3.6 -10.9]	95.9 [+5.0 -12.8]
α [deg] (dir. meas.)	88.7 [+4.6 -4.2]	88.7 [+9.4 -8.5]	89 [+21 -13]
β [deg]	21.85 [+0.80 -0.77]	21.9 [+1.6 -1.3]	21.9 [+2.5 -1.8]
β [deg] (meas. not in the fit)	27.5 [+1.2 -1.4]	27.5 [+1.9 -3.9]	27.5 [+2.6 -6.8]
β [deg] (dir. meas.)	21.38 [+0.79 -0.77]	21.4 [+1.6 -1.5]	21.4 [+2.4 -2.3]
γ [deg]	67.1 [+4.3 -4.3]	67.1 [+6.1 -7.0]	67.1 [+7.6 -8.5]
γ [deg] (meas. not in the fit)	67.2 [+4.4 -4.6]	67.2 [+6.1 -7.2]	67.2 [+7.6 -8.7]
γ [deg] (dir. meas.)	66 [+12 -12]	66 [+23 -22]	66 [+36 -30]

K Oscillations - I

First among a host of astonishing quantum mechanical oddities

$$|K^0\rangle = |d\bar{s}\rangle \quad S = +1$$

$$|\bar{K}^0\rangle = |\bar{d}s\rangle \quad S = -1$$

$$P|K^0\rangle = -|K^0\rangle \quad \text{Pseudoscalar}$$

$$P|\bar{K}^0\rangle = -|\bar{K}^0\rangle \quad \text{Pseudoscalar}$$

$$C|K^0\rangle = |\bar{K}^0\rangle \quad \text{Not a C eigenstate}$$

$$C|\bar{K}^0\rangle = |K^0\rangle \quad \text{Not a C eigenstate}$$

→ Make C eigenstates:

$$|K_1^0\rangle = \frac{1}{\sqrt{2}}(|K^0\rangle - |\bar{K}^0\rangle) \rightarrow C|K_1^0\rangle = C\left[\frac{1}{\sqrt{2}}(|K^0\rangle - |\bar{K}^0\rangle)\right] = \frac{1}{\sqrt{2}}(|\bar{K}^0\rangle - |K^0\rangle) = -|K_1^0\rangle$$

$$|K_2^0\rangle = \frac{1}{\sqrt{2}}(|K^0\rangle + |\bar{K}^0\rangle) \rightarrow C|K_2^0\rangle = |K_2^0\rangle$$

K Oscillations - II

Kaons : Just weak decays (\leftarrow Lightest strange hadron)

C, P not conserved by weak processes

CP almost conserved by weak processes \rightarrow Take it as good for the moment

\rightarrow Focus on CP as a symmetry for weak processes

CP eigenstates:

$$CP|K_1^0\rangle = CP\left[\frac{1}{\sqrt{2}}(|K^0\rangle - |\bar{K}^0\rangle)\right] = C\left[\frac{1}{\sqrt{2}}(-|K^0\rangle + |\bar{K}^0\rangle)\right] = +|K_1^0\rangle \quad CP = +1$$

$$CP|K_2^0\rangle = -|K_2^0\rangle \quad CP = -1$$

Observe : K_1^0, K_2^0 CP eigenstates, like photon, π^0

\rightarrow Different particles

K Oscillations - III

K^0 : Many different decay modes, including weak decays into pions

Consider first decays into 2 π 's:

$K^0 \rightarrow \pi^0 \pi^0$

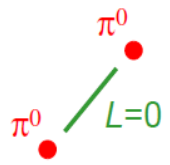

$J^P: 0^- \rightarrow 0^- + 0^-$
Ang. mom. conservation
 $\Rightarrow L=0$

$\Rightarrow P(\pi^0 \pi^0) = -1 \cdot -1 \cdot (-1)^L = (-1)^L = +1$

π^0 is eigenstate of C : $\hat{C}|\pi^0\rangle = +|\pi^0\rangle$

$\Rightarrow C(\pi^0 \pi^0) = +1 \cdot +1 = +1$

$K^0 \rightarrow \pi^+ \pi^-$

Still have $L=0$
 $\Rightarrow P(\pi^+ \pi^-) = -1 \cdot -1 \cdot (-1)^L = (-1)^L = +1$

C and P operations have identical effect :

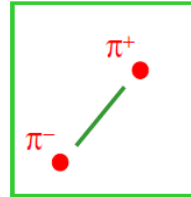

$\xrightarrow{\hat{C}}$
 $\xrightarrow{\hat{P}}$

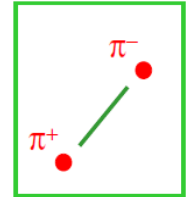

(no spins involved)

$\Rightarrow C(\pi^+ \pi^-) = P(\pi^+ \pi^-) = (-1)^L = +1$

\Rightarrow **CP = +1** for both $\pi^+ \pi^-$ and $\pi^0 \pi^0$

K Oscillations - IV

Consider then decays into 3 π 's:

$$K^0 \rightarrow \pi^0 \pi^0 \pi^0$$

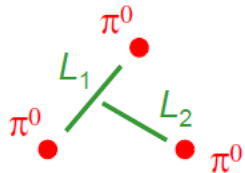

$$J^P: 0^- \rightarrow 0^- + 0^- + 0^-$$

Ang. mom. conservation

$$\Rightarrow L_1 \oplus L_2 = 0$$

$$\Rightarrow L_1 = L_2$$

$$\Rightarrow P(\pi^0 \pi^0 \pi^0) = -1 \cdot -1 \cdot -1 \cdot (-1)^{L_1} \cdot (-1)^{L_2} = -1$$

$$C(\pi^0 \pi^0 \pi^0) = +1 \cdot +1 \cdot +1 = +1$$

$$K^0 \rightarrow \pi^+ \pi^- \pi^0$$

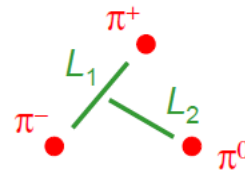

As above: $L_1 = L_2$

$$\Rightarrow P(\pi^+ \pi^- \pi^0) = -1 \cdot -1 \cdot -1 \cdot (-1)^{L_1} \cdot (-1)^{L_2} = -1$$

$$C(\pi^+ \pi^- \pi^0) = +1 \cdot C(\pi^+ \pi^-) = +1 \cdot (-1)^{L_1} = +1$$

Experimentally: $L_1 = 0$ from study
of angular distributions of π^+ , π^-

$$\Rightarrow \text{CP} = -1 \quad \text{for both } \pi^+ \pi^- \pi^0 \text{ and } \pi^0 \pi^0 \pi^0$$

K Oscillations - V

If CP is conserved in weak processes:

$$\left. \begin{array}{l} K_1^0 \rightarrow \pi\pi \\ K_2^0 \rightarrow \pi\pi\pi \end{array} \right\} \textit{Exclusively}$$

Summary so far about neutral K states:

Production (by strong interaction): $|K^0\rangle, |\bar{K}^0\rangle$

Decay (by weak interaction): $|K_1^0\rangle, |K_2^0\rangle$

$$m_{|K^0\rangle} = m_{|\bar{K}^0\rangle} \approx m_{|K_1^0\rangle} \approx m_{|K_2^0\rangle} \approx 498 \text{ MeV}$$

Expect, and find:

$$K_1^0 \rightarrow \pi\pi \quad \text{Fast: Larger phase space etc} \quad \rightarrow \tau_1 = 0.9 \cdot 10^{-10} \text{ s } \textit{'K short'}$$

$$K_2^0 \rightarrow \pi\pi\pi \quad \text{Slow: Smaller phase space etc} \quad \rightarrow \tau_2 = 0.5 \cdot 10^{-7} \text{ s } \textit{'K long'}$$

K Oscillations - VI

Provisionally identify:

$$K_S \equiv K_1^0 (\rightarrow \pi\pi) \quad \tau_S = 0.9 \cdot 10^{-10} \text{ s} \quad \text{'K short'} \quad CP = +1$$

$$K_L \equiv K_2^0 (\rightarrow \pi\pi\pi) \quad \tau_L = 0.5 \cdot 10^{-7} \text{ s} \quad \text{'K long'} \quad CP = -1$$

Therefore:

$$K_S \equiv K_1^0, K_L \equiv K_2^0 : \begin{array}{ll} \text{Different} & CP \\ \text{Different} & \text{lifetime} \end{array}$$

Also: Different mass!

Old fashioned (but simple) argument:

Different virtual weak couplings, 2π vs 3π

→ Different corrections to the mass

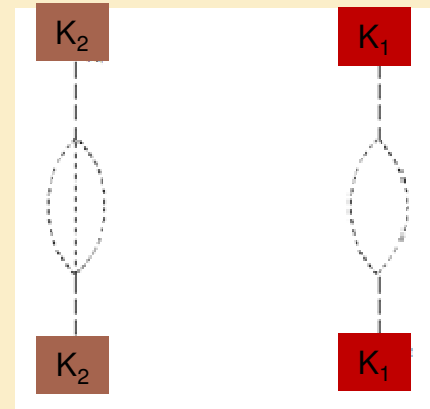

K Oscillations - VII

Taking a neutral K beam produced by strong interaction, expect qualitatively

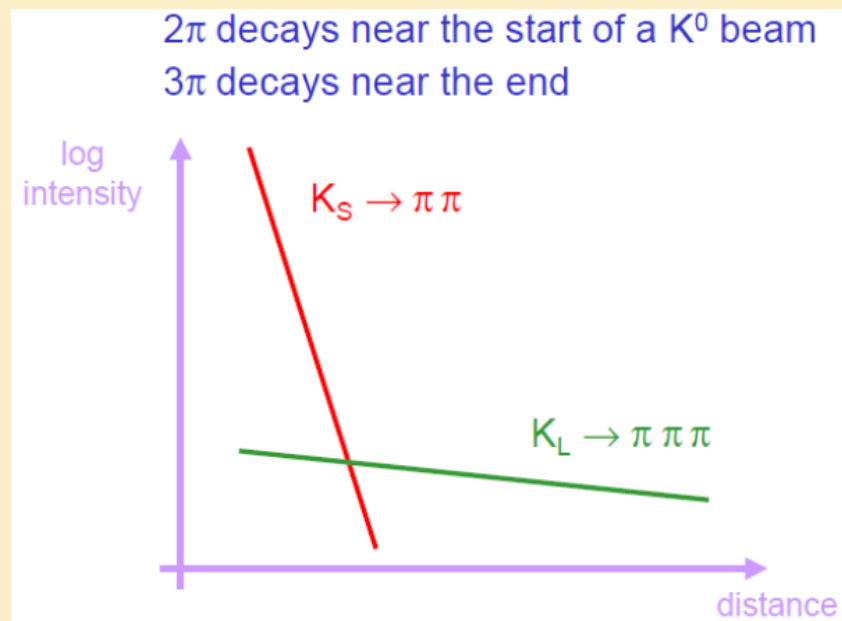

K Oscillations - VIII

Production: Strong interaction \rightarrow Strangeness conserved

Neglect weak interaction in production process

Strongly produced neutral K either K^0 or \bar{K}^0

\rightarrow Either K^0 or \bar{K}^0 as *initial condition* for the K wave function

Time evolution : Weak interaction \rightarrow Strangeness *not* conserved

Neglect strong interaction in time evolution

Neither P or C conserved by weak interaction; CP (*provisionally*) conserved

\rightarrow Propagate CP eigenstates K_S, K_L

Take a definite production process:

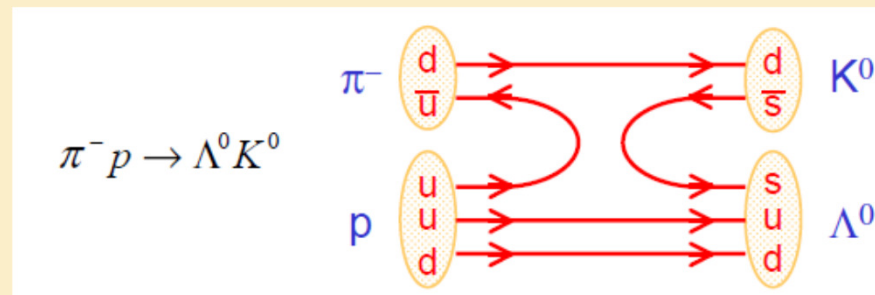

K Oscillations - IX

$$\psi(t=0): |K^0\rangle = \frac{1}{\sqrt{2}}(|K_L^0\rangle + |K_S^0\rangle)$$

$$\begin{cases} |K_L^0(t)\rangle = |K_L^0\rangle e^{-i(m_L - i\frac{\Gamma_L}{2})t}, & \Gamma_L = \frac{1}{\tau_L} \\ |K_S^0(t)\rangle = |K_S^0\rangle e^{-i(m_S - i\frac{\Gamma_S}{2})t}, & \Gamma_S = \frac{1}{\tau_S} \end{cases}$$

$$\rightarrow \psi(t) = \frac{1}{\sqrt{2}} \left(|K_L^0\rangle e^{-i(m_L - i\frac{\Gamma_L}{2})t} + |K_S^0\rangle e^{-i(m_S - i\frac{\Gamma_S}{2})t} \right)$$

$$\rightarrow \psi(t) = \frac{1}{\sqrt{2}} \left[\left[\frac{1}{\sqrt{2}} (|K^0\rangle + |\bar{K}^0\rangle) \right] e^{-i(m_L - i\frac{\Gamma_L}{2})t} + \frac{1}{\sqrt{2}} (|K^0\rangle - |\bar{K}^0\rangle) \frac{1}{\sqrt{2}} e^{-i(m_S - i\frac{\Gamma_S}{2})t} \right]$$

$$\rightarrow \psi(t) = \frac{1}{2} \left(|K^0\rangle \left[e^{-i(m_L - i\frac{\Gamma_L}{2})t} + e^{-i(m_S - i\frac{\Gamma_S}{2})t} \right] + |\bar{K}^0\rangle \left[e^{-i(m_L - i\frac{\Gamma_L}{2})t} - e^{-i(m_S - i\frac{\Gamma_S}{2})t} \right] \right)$$

K Oscillations - X

Time evolution of strangeness content of the beam:

Initial condition K^0

$$\Delta m = m_L - m_S$$

$$\rightarrow \begin{cases} I(K^0) = \frac{1}{4} \left| e^{-i\left(m_L - i\frac{\Gamma_L}{2}\right)t} + e^{-i\left(m_S - i\frac{\Gamma_S}{2}\right)t} \right|^2 = \frac{1}{4} \left[e^{-\Gamma_L t} + e^{-\Gamma_S t} + 2e^{-\frac{(\Gamma_L + \Gamma_S)}{2}t} \cos \Delta m t \right] \\ I(\bar{K}^0) = \frac{1}{4} \left| e^{-i\left(m_L - i\frac{\Gamma_L}{2}\right)t} - e^{-i\left(m_S - i\frac{\Gamma_S}{2}\right)t} \right|^2 = \frac{1}{4} \left[e^{-\Gamma_L t} + e^{-\Gamma_S t} - 2e^{-\frac{(\Gamma_L + \Gamma_S)}{2}t} \cos \Delta m t \right] \end{cases}$$

→ Strangeness oscillations

Detected in many ways, for example by semileptonic modes:

$$\begin{array}{l} K^0 \rightarrow \pi^- e^+ \nu_e \\ \bar{K}^0 \rightarrow \pi^+ e^- \bar{\nu}_e \end{array}$$

$\Delta Q = \Delta S$ rule: Unambiguous strangeness assignment from decay products

K Oscillations - XI

Interference!

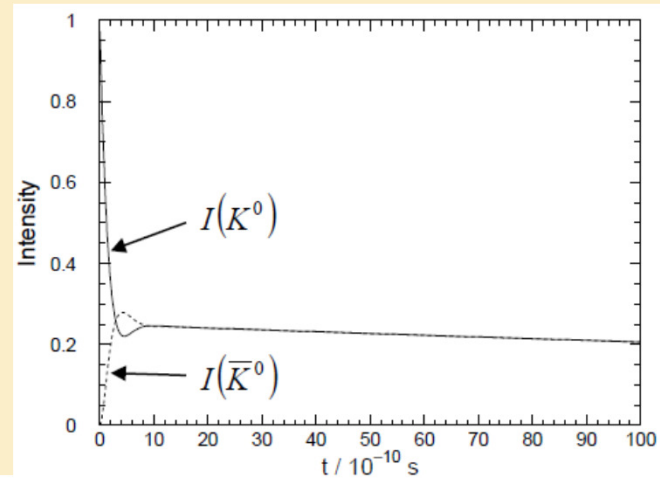

Expanded timescale:

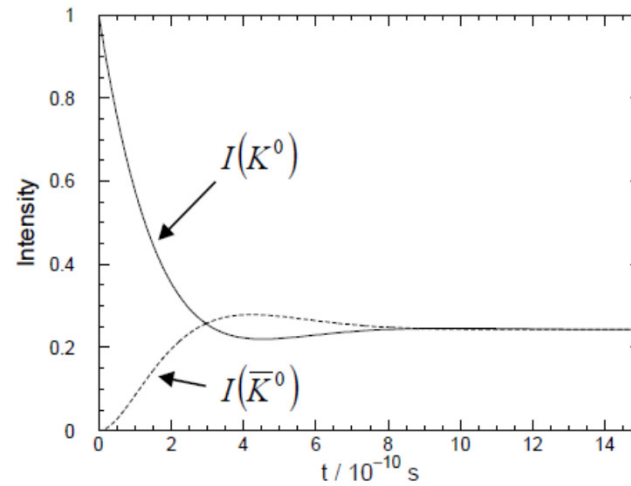

K Oscillations - XII

...And it's true!

Semileptonic decays

$$\frac{N_{\pi^+} - N_{\pi^-}}{N_{\pi^+} + N_{\pi^-}}$$

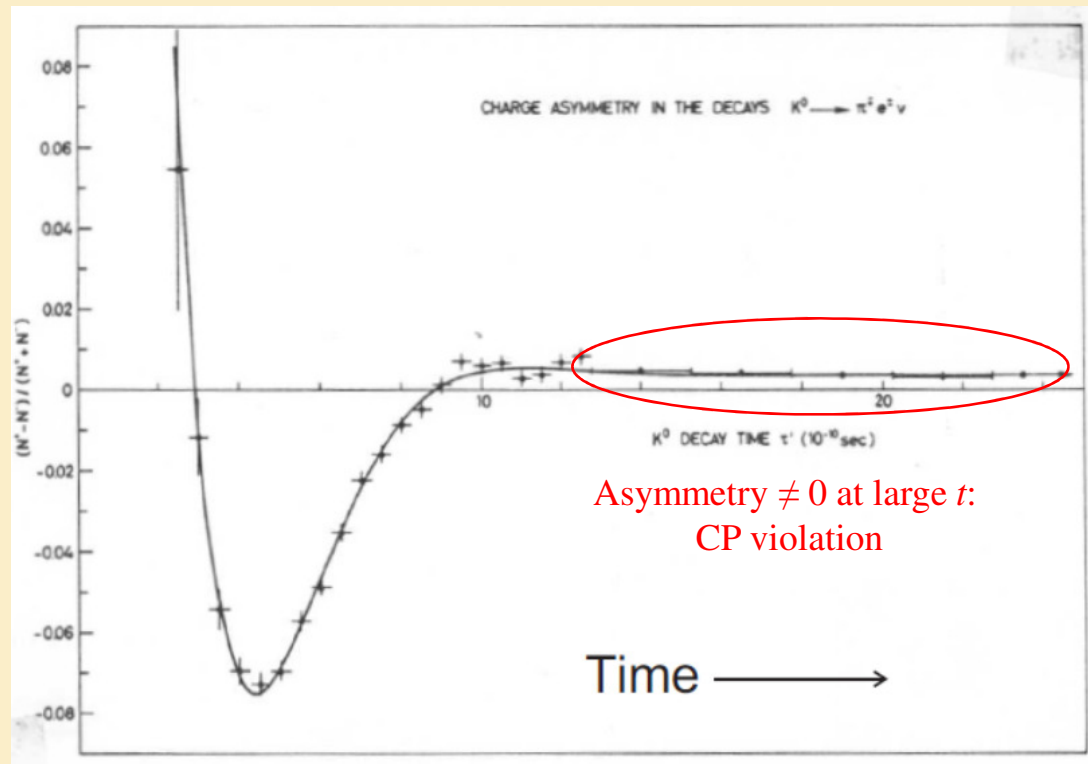

!!!

K Oscillations - XIII

CPLEAR experiment fit to Δm

$$R_+ \equiv \Gamma(K_{t=0}^0 \rightarrow \pi^- e^+ \nu_e)$$

$$R_- \equiv \Gamma(K_{t=0}^0 \rightarrow \pi^+ e^- \bar{\nu}_e)$$

$$\bar{R}_- \equiv \Gamma(\bar{K}_{t=0}^0 \rightarrow \pi^+ e^- \bar{\nu}_e)$$

$$\bar{R}_+ \equiv \Gamma(\bar{K}_{t=0}^0 \rightarrow \pi^- e^+ \nu_e)$$

$$A_{\Delta m} = \frac{(R_+ + \bar{R}_-) - (R_- + \bar{R}_+)}{(R_+ + \bar{R}_-) + (R_- + \bar{R}_+)}$$

$$A_{\Delta m} = \frac{2e^{-(\Gamma_S + \Gamma_L)t/2} \cos \Delta m t}{e^{-\Gamma_S t} + e^{-\Gamma_L t}}$$

$$\Delta m = 3.485 \times 10^{-15} \text{ GeV}$$

!!!

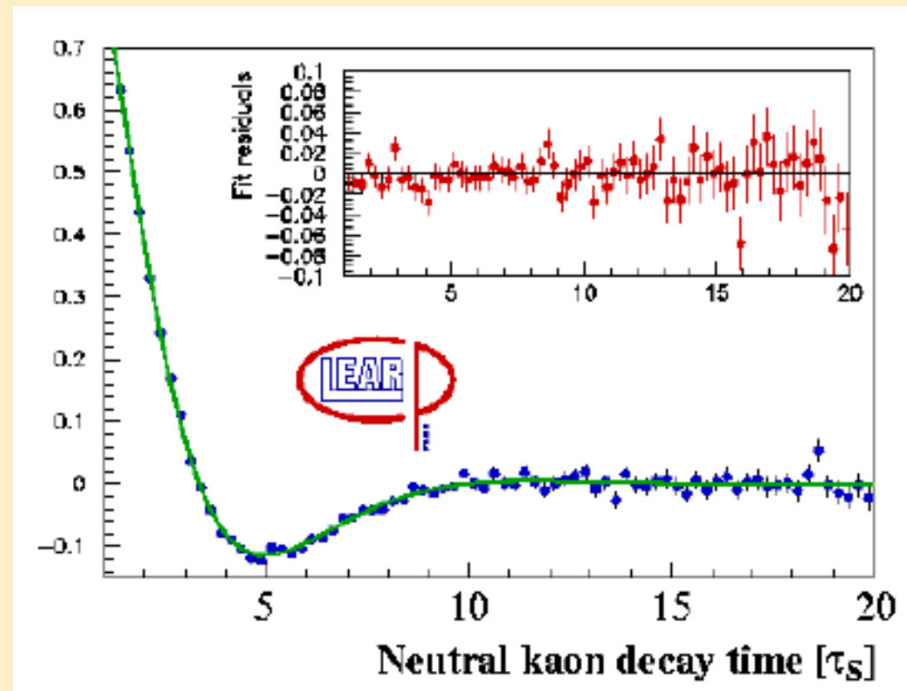

K Oscillations - XIV

Observe:

$$T(K^0 \leftrightarrow \bar{K}^0) = \frac{2\pi}{\Delta m}$$

$$\rightarrow T(K^0 \leftrightarrow \bar{K}^0) = \frac{2\pi}{3.49 \cdot 10^{-12} \text{ MeV}} = \frac{2\pi}{3.49 \cdot 10^{-12} \text{ MeV}} \underbrace{6.5810^{-22} \text{ MeVs}}_{\hbar} \simeq 1.18 \text{ ns}$$

$$\tau_S \simeq 8.9510^{-11} \text{ s}$$

$$\rightarrow \frac{T}{\tau_S} \approx 13.3$$

→ Just a fraction of a single oscillation within a K_S lifetime

K Oscillations - XV

Summary of decay rates (CP conserved):

2 lifetimes ($2\pi, 3\pi$)

Strangeness oscillations (Semileptonic)

2 masses ($2\pi, 3\pi$)

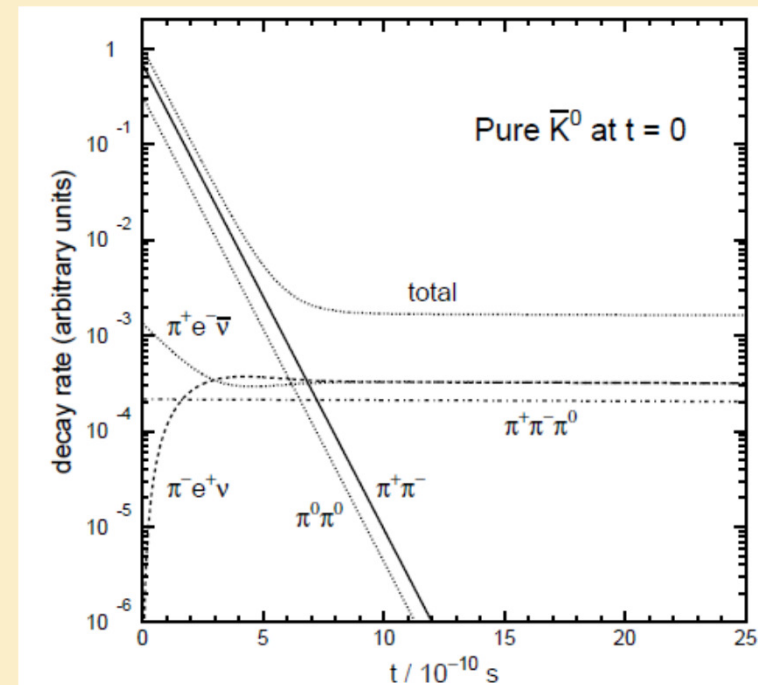
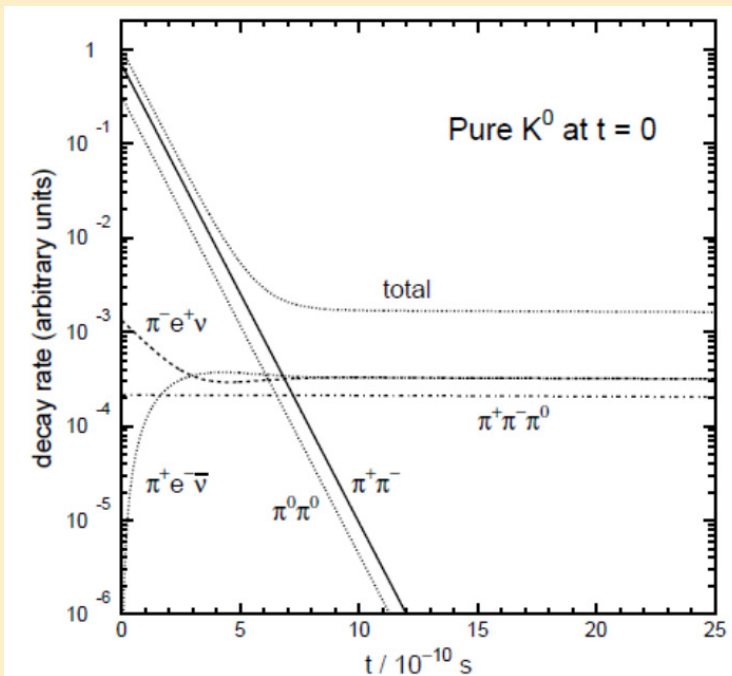

K_S Regeneration - I

Production reactions (e.g. at low energy):

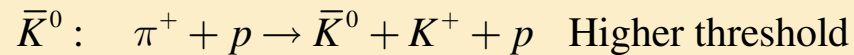
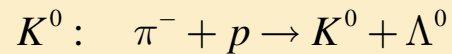

Take first reaction \rightarrow Initially pure K^0 beam

After several τ_s : K_S component off \rightarrow Pure K_L beam

Introduce some material in the beam path: Funny effect!

K_S Regeneration - II

Total cross section different for K^0, \bar{K}^0 :

Indeed, e.g.

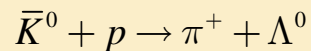

is strictly forbidden for K^0

$$\rightarrow \sigma_{K^0} \neq \sigma_{\bar{K}^0}$$

Remembering the "OpticalTheorem":

$$\sigma_{tot} = \frac{4\pi}{k} \text{Im } f(0), \quad f(0) \text{ forward scattering amplitude}$$

$$\rightarrow f_{K^0}(0) \neq f_{\bar{K}^0}(0)$$

Take forward scattering (= *propagation*) of our pure K_L beam:

$$|K_L\rangle = \frac{1}{\sqrt{2}}(|K^0\rangle + |\bar{K}^0\rangle) \rightarrow \frac{1}{\sqrt{2}}(A(f_{K^0})|K^0\rangle + B(f_{\bar{K}^0})|\bar{K}^0\rangle) \neq |K_L\rangle$$

$$|K_L\rangle \rightarrow a|K_L\rangle + b|K_S\rangle, \quad |a|^2 + |b|^2 = 1$$

\rightarrow A $|K_S\rangle$ component has been regenerated by the material!

K_S Regeneration - III

Piccioni et al. – Berkeley \approx 1956

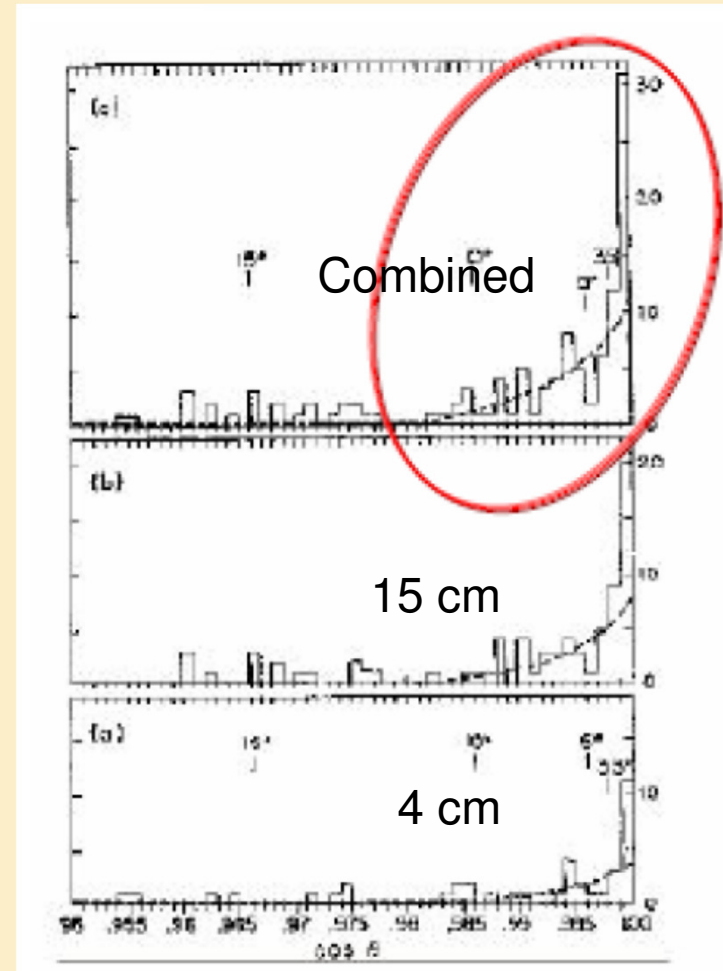
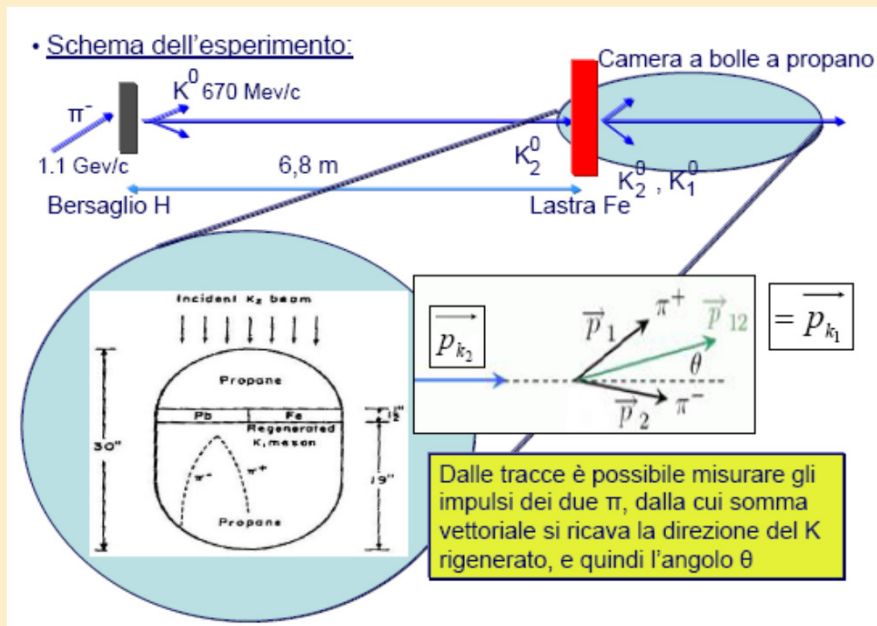

K_S Regeneration - IV

KTEV - Fermilab ≈ 2000

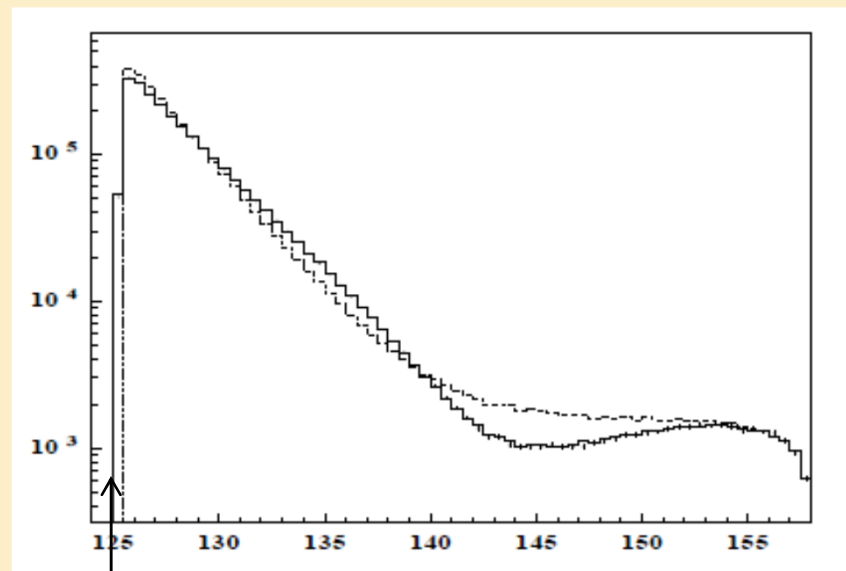
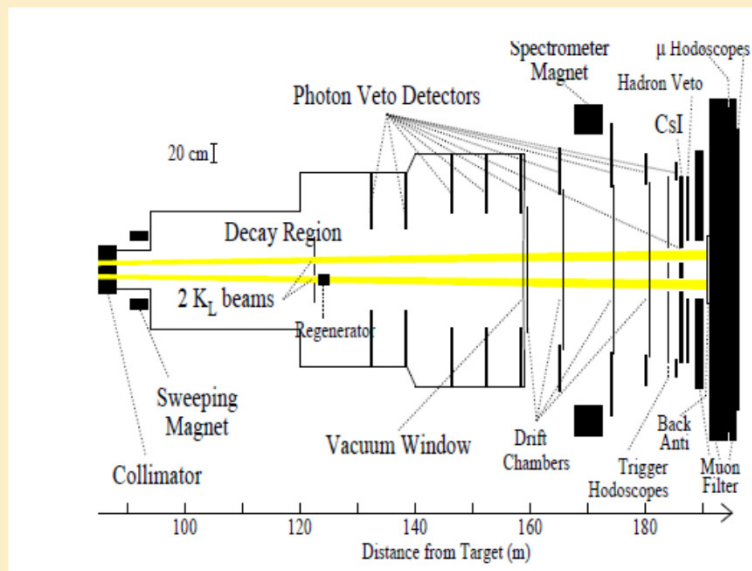

Regenerator

Strong K_S regeneration signalled by 2π decays with τ_s lifetime

[Large interference observed in 2π rate:

Regenerated K_S component interfering with CP violating, 2π decay of K_L beam]

K CP Violation - I

$K_2 \rightarrow \pi^+\pi^-$ decay observed in 1964; $K_2 \rightarrow \pi^0\pi^0$ decay also observed

Small $BR \sim 10^{-3}$

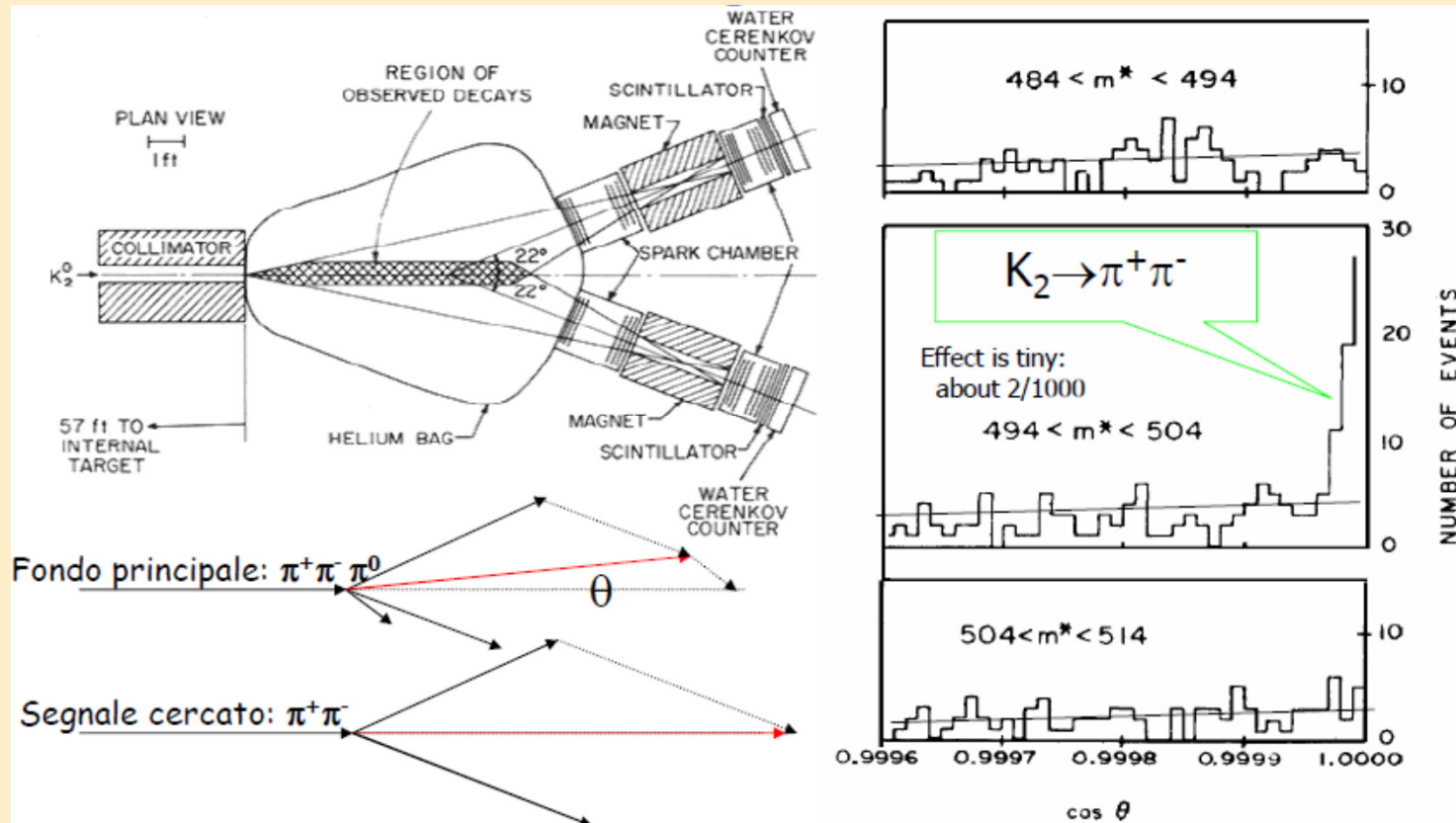

K CP Violation - II

Three possible mechanisms:

1) K_L, K_S not CP eigenstates - Decay CP conserving

$$\rightarrow |K_L^0\rangle = \frac{1}{\sqrt{1+|\varepsilon|^2}} (|K_2^0\rangle + \varepsilon |K_1^0\rangle), |K_S^0\rangle = \frac{1}{\sqrt{1+|\varepsilon|^2}} (|K_1^0\rangle - \varepsilon |K_2^0\rangle)$$

$K_L^0 \rightarrow \pi\pi$ accounted for by

$$|K_L^0\rangle = \frac{1}{\sqrt{1+|\varepsilon|^2}} \left(\begin{array}{c} |K_2^0\rangle + \varepsilon |K_1^0\rangle \\ \downarrow \pi\pi \quad \downarrow \pi\pi \end{array} \right) \quad \text{Mixing } \cancel{CP}: \text{ Measured by small parameter } \varepsilon$$

2) Decay CP violating - K_L, K_S CP eigenstates

$$|K_L^0\rangle = |K_2^0\rangle \quad \text{Direct } \cancel{CP}: \text{ Measured by very small parameter } \varepsilon'$$

3) Interference between mixing and decay

K CP Violation - III

Define:

$$|\eta_{+-}| \equiv \frac{\Gamma(K_L^0 \rightarrow \pi^+ \pi^-)}{\Gamma(K_S^0 \rightarrow \pi^+ \pi^-)} = (2.276 \pm 0.017) \times 10^{-3}$$

$$|\eta_{00}| \equiv \frac{\Gamma(K_L^0 \rightarrow \pi^0 \pi^0)}{\Gamma(K_S^0 \rightarrow \pi^0 \pi^0)} = (2.262 \pm 0.017) \times 10^{-3}$$

Expect:

$$\text{Case 1) } \rightarrow \eta_{+-} = \eta_{00}$$

$$\text{Case 2) } \rightarrow \eta_{+-} \neq \eta_{00}$$

Generally (see later):

$$\eta_{+-} = \varepsilon + \varepsilon'$$

$$\eta_{+-} = \varepsilon - 2\varepsilon'$$

$\rightarrow \varepsilon' \ll \varepsilon$, must be very small

K CP Violation - IV

Focus on mixing \mathcal{CP} , ignore direct \mathcal{CP} for the moment

$\varepsilon = |\varepsilon|e^{i\varphi}$ Measuring mixing \mathcal{CP}

For a neutral beam initially pure K^0 / \bar{K}^0 :

$\pi\pi$ decay rate as a function of distance

$$I(K^0; t) = \frac{N}{2}(1 - 2\text{Re}(\varepsilon)) \left[e^{-\Gamma_S t} + \underbrace{|\varepsilon|^2 e^{-\Gamma_L t}}_{K_L \text{ contribution}} + \underbrace{2|\varepsilon| e^{-\frac{\Gamma_L + \Gamma_S}{2} t} \cos(\Delta m t - \varphi)}_{\text{Interference}} \right]$$
$$I(\bar{K}^0; t) = \frac{N}{2}(1 + 2\text{Re}(\varepsilon)) \left[e^{-\Gamma_S t} + |\varepsilon|^2 e^{-\Gamma_L t} - 2|\varepsilon| e^{-\frac{\Gamma_L + \Gamma_S}{2} t} \cos(\Delta m t - \varphi) \right]$$

→ Get $|\varepsilon|, \varphi, \Delta m$

$$|\varepsilon| = (2.285 \pm 0.019) \times 10^{-3}$$
$$\phi = (43.5 \pm 0.6)^\circ$$

K CP Violation - V

...Quite correct!

Pure interference term

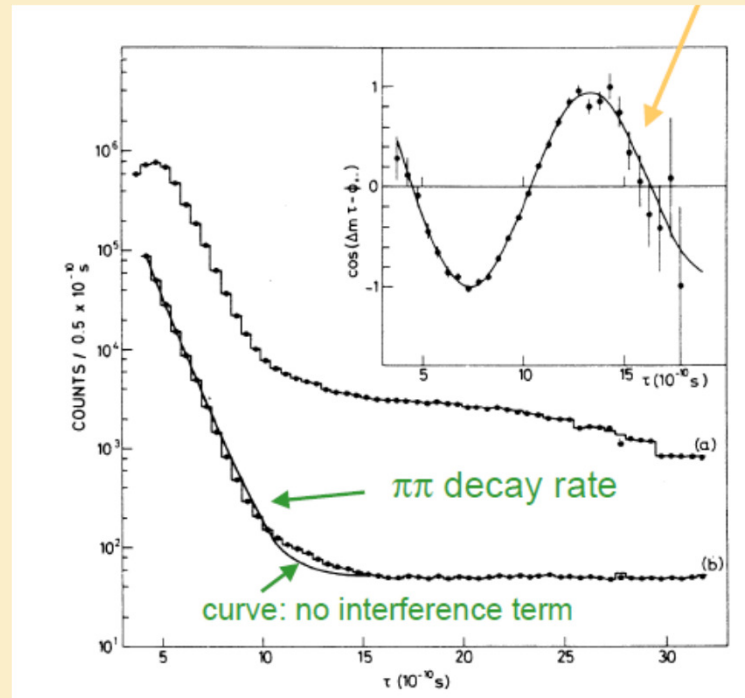

Similar to regeneration data, but : No regenerator !

Interference between K_L and K_S in 2π decay

→ K_L and K_S states not orthogonal: Both have a K_1 component

K *CP* Violation - VI

Neutral beam at large distance from production target: Pure K_L

$$|K_L^0\rangle = \frac{1}{\sqrt{1+|\varepsilon|^2}} (|K_2^0\rangle + \varepsilon |K_1^0\rangle)$$

$$\rightarrow |K_L^0\rangle = \frac{1}{\sqrt{2(1+|\varepsilon|^2)}} [(1+\varepsilon)|K^0\rangle + (1-\varepsilon)|\bar{K}^0\rangle]$$

$$\rightarrow |K_S^0\rangle = \frac{1}{\sqrt{2(1+|\varepsilon|^2)}} [(1+\varepsilon)|K^0\rangle - (1-\varepsilon)|\bar{K}^0\rangle]$$

Take semileptonic decays, e.g. K_{e3} :

$$K^0 \rightarrow \pi^- e^+ \nu_e$$

$$\bar{K}^0 \rightarrow \pi^+ e^- \bar{\nu}_e$$

Observe:

$$CP|K^0\rangle = |\bar{K}^0\rangle$$

$$CP|\pi^- e^+ \nu_e\rangle = |\pi^+ e^- \bar{\nu}_e\rangle$$

→ No *CP* eigenstates

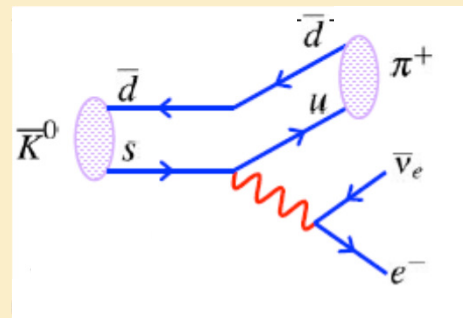

K CP Violation - VII

Define CP violation asymmetry for semileptonic decays (K_{e3})

$$\delta = \frac{\Gamma(K_L \rightarrow \pi^- e^+ \nu_e) - \Gamma(K_L \rightarrow \pi^+ e^- \bar{\nu}_e)}{\Gamma(K_L \rightarrow \pi^- e^+ \nu_e) + \Gamma(K_L \rightarrow \pi^+ e^- \bar{\nu}_e)}$$

$$\Gamma(K_L \rightarrow \pi^+ e^- \bar{\nu}_e) \propto |\langle K^0 | K_L \rangle|^2 \propto |1 - \varepsilon|^2$$

$$\Gamma(K_L \rightarrow \pi^- e^+ \nu_e) \propto |\langle \bar{K}^0 | K_L \rangle|^2 \propto |1 + \varepsilon|^2$$

$$|1 \pm \varepsilon|^2 = (1 \pm \varepsilon)(1 \pm \varepsilon^*) \approx 1 + \varepsilon + \varepsilon^* = 1 \pm 2 \operatorname{Re} \varepsilon$$

$$\rightarrow \delta \approx \frac{(1 + 2 \operatorname{Re} \varepsilon) - (1 - 2 \operatorname{Re} \varepsilon)}{(1 + 2 \operatorname{Re} \varepsilon) + (1 - 2 \operatorname{Re} \varepsilon)} = \frac{4 \operatorname{Re} \varepsilon}{2} = 2 \operatorname{Re} \varepsilon = 2 |\varepsilon| \cos \phi$$

$$\rightarrow \delta \approx 3.2110^{-3} \text{ calculated by taking } \varepsilon \text{ from } \pi\pi$$

Measured: $(3.27 \pm 0.012)10^{-3}$

K *CP* Violation - VIII

CPLEAR – CERN '90s

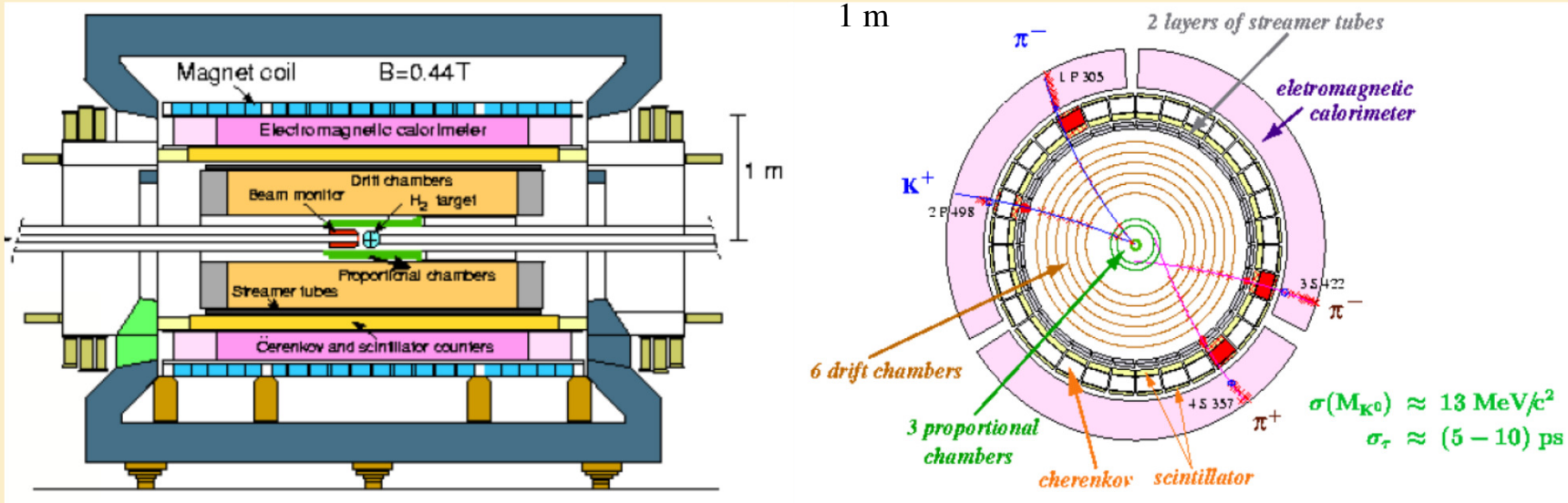

K CP Violation - IX

Experiment CPLEAR

(CERN \bar{p} Low Energy Accumulator Ring - LEAR) $\rightarrow \sim 1995$

Use reactions:

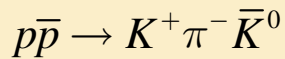
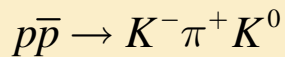

and semileptonic decays

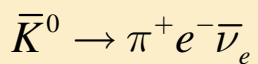
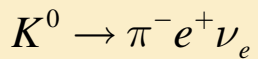

Strangeness of *produced* K state: Tagged *unambiguously*
of *decaying*

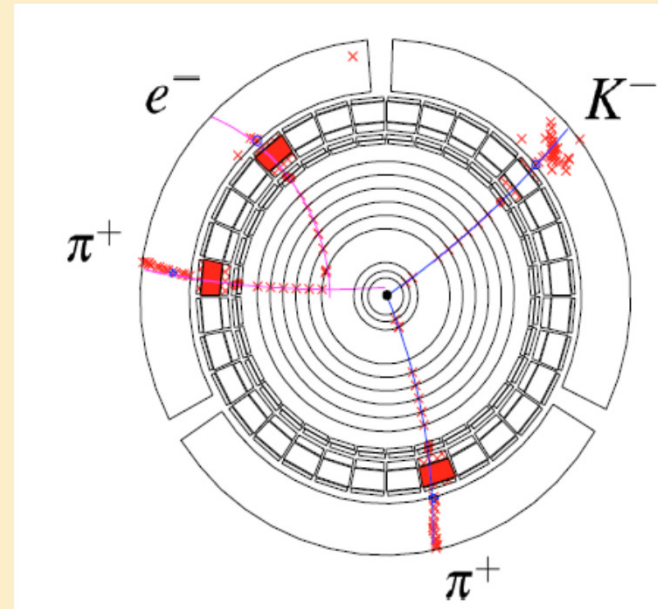

K CP Violation - X

Strangeness oscillations in presence of \mathcal{CP} :

$$R_+ = \Gamma(K_{t=0}^0 \rightarrow \pi^- e^+ \nu_e) = N \frac{1}{4} \left[e^{-\Gamma_S t} + e^{-\Gamma_L t} + 2e^{-\frac{\Gamma_S + \Gamma_L}{2} t} \cos \Delta m t \right]$$

$$R_- = \Gamma(K_{t=0}^0 \rightarrow \pi^+ e^- \bar{\nu}_e) = N(1 - 4\text{Re}\epsilon) \frac{1}{4} \left[e^{-\Gamma_S t} + e^{-\Gamma_L t} - 2e^{-\frac{\Gamma_S + \Gamma_L}{2} t} \cos \Delta m t \right]$$

$$\bar{R}_+ = \Gamma(\bar{K}_{t=0}^0 \rightarrow \pi^- e^+ \nu_e) = N(1 + 4\text{Re}\epsilon) \frac{1}{4} \left[e^{-\Gamma_S t} + e^{-\Gamma_L t} - 2e^{-\frac{\Gamma_S + \Gamma_L}{2} t} \cos \Delta m t \right]$$

$$\bar{R}_- = \Gamma(\bar{K}_{t=0}^0 \rightarrow \pi^+ e^- \bar{\nu}_e) = N \frac{1}{4} \left[e^{-\Gamma_S t} + e^{-\Gamma_L t} + 2e^{-\frac{\Gamma_S + \Gamma_L}{2} t} \cos \Delta m t \right]$$

$$A_{\Delta m} = \frac{(R_+ + \bar{R}_-) - (R_- + \bar{R}_+)}{(R_+ + \bar{R}_-) + (R_- + \bar{R}_+)} = \frac{2e^{-\frac{\Gamma_S + \Gamma_L}{2} t} \cos \Delta m t}{e^{-\Gamma_S t} + e^{-\Gamma_L t}}$$

$$\rightarrow A_{\Delta m}(\mathcal{CP}) = A_{\Delta m}(CP)$$

Asymmetry not sensitive to CP violation

K CP Violation - XI

Decays into 2 π 's: Time dependent asymmetry

$$A(\pi\pi) = \frac{\Gamma(\bar{K}^0 \rightarrow \pi\pi) - \Gamma(K^0 \rightarrow \pi\pi)}{\Gamma(\bar{K}^0 \rightarrow \pi\pi) + \Gamma(K^0 \rightarrow \pi\pi)}$$

$$I(K^0; t) = \frac{N}{2} (1 - 2\text{Re}(\varepsilon)) \left[e^{-\Gamma_s t} + |\varepsilon|^2 e^{-\Gamma_L t} + 2|\varepsilon| e^{-\frac{\Gamma_L + \Gamma_s}{2} t} \cos(\Delta m t - \varphi) \right]$$

$$I(\bar{K}^0; t) = \frac{N}{2} (1 + 2\text{Re}(\varepsilon)) \left[e^{-\Gamma_s t} + |\varepsilon|^2 e^{-\Gamma_L t} - 2|\varepsilon| e^{-\frac{\Gamma_L + \Gamma_s}{2} t} \cos(\Delta m t - \varphi) \right]$$

$$I(\bar{K}^0; t) \approx \frac{N}{2} \left[e^{-\Gamma_s t} + |\varepsilon|^2 e^{-\Gamma_L t} - 2|\varepsilon| e^{-\frac{\Gamma_L + \Gamma_s}{2} t} \cos(\Delta m t - \varphi) + 2\text{Re}(\varepsilon) e^{-\Gamma_s t} - 4\text{Re}(\varepsilon)|\varepsilon| e^{-\frac{\Gamma_L + \Gamma_s}{2} t} \cos(\Delta m t - \varphi) \right]$$

$$I(K^0; t) \approx \frac{N}{2} \left[e^{-\Gamma_s t} + |\varepsilon|^2 e^{-\Gamma_L t} + 2|\varepsilon| e^{-\frac{\Gamma_L + \Gamma_s}{2} t} \cos(\Delta m t - \varphi) - 2\text{Re}(\varepsilon) e^{-\Gamma_s t} - 4\text{Re}(\varepsilon)|\varepsilon| e^{-\frac{\Gamma_L + \Gamma_s}{2} t} \cos(\Delta m t - \varphi) \right]$$

$$I(\bar{K}^0; t) - I(K^0; t) \approx N \left[-2|\varepsilon| e^{-\frac{\Gamma_L + \Gamma_s}{2} t} \cos(\Delta m t - \varphi) + 2\text{Re}(\varepsilon) e^{-\Gamma_s t} \right]$$

$$I(\bar{K}^0; t) + I(K^0; t) \approx N \left[e^{-\Gamma_s t} + |\varepsilon|^2 e^{-\Gamma_L t} - 4\text{Re}(\varepsilon)|\varepsilon| e^{-\frac{\Gamma_L + \Gamma_s}{2} t} \right]$$

K CP Violation - XII

$$A(\pi\pi) \approx \frac{-2|\varepsilon|e^{-\frac{\Gamma_L+\Gamma_S}{2}t} \cos(\Delta mt - \varphi) + 2\text{Re}(\varepsilon)e^{-\Gamma_S t}}{e^{-\Gamma_S t} + |\varepsilon|^2 e^{-\Gamma_L t} - 4\text{Re}(\varepsilon)|\varepsilon|e^{-\frac{\Gamma_L+\Gamma_S}{2}t}}$$

Keeping only terms linear in $|\varepsilon|$:

$$A \approx \frac{4\text{Re}(\varepsilon)e^{-\Gamma_S t} - 4|\varepsilon|e^{-\frac{\Gamma_L+\Gamma_S}{2}t} \cos(\Delta mt - \varphi)}{2e^{-\Gamma_S t}} = 2\text{Re}(\varepsilon) - 2|\varepsilon|e^{\frac{\Gamma_S-\Gamma_L}{2}t} \cos(\Delta mt - \varphi)$$

$$\rightarrow A(\pi\pi) \approx 2 \left[\text{Re}(\varepsilon) - |\varepsilon|e^{\frac{(\Gamma_S-\Gamma_L)}{2}t} \cos(\Delta mt - \phi) \right]$$

K CP Violation - XIII

CPLEAR on 2π decays

Expected decay rates
for K^0 , \bar{K}^0 initial state

Observed decay rates
for K^0 , \bar{K}^0 initial state

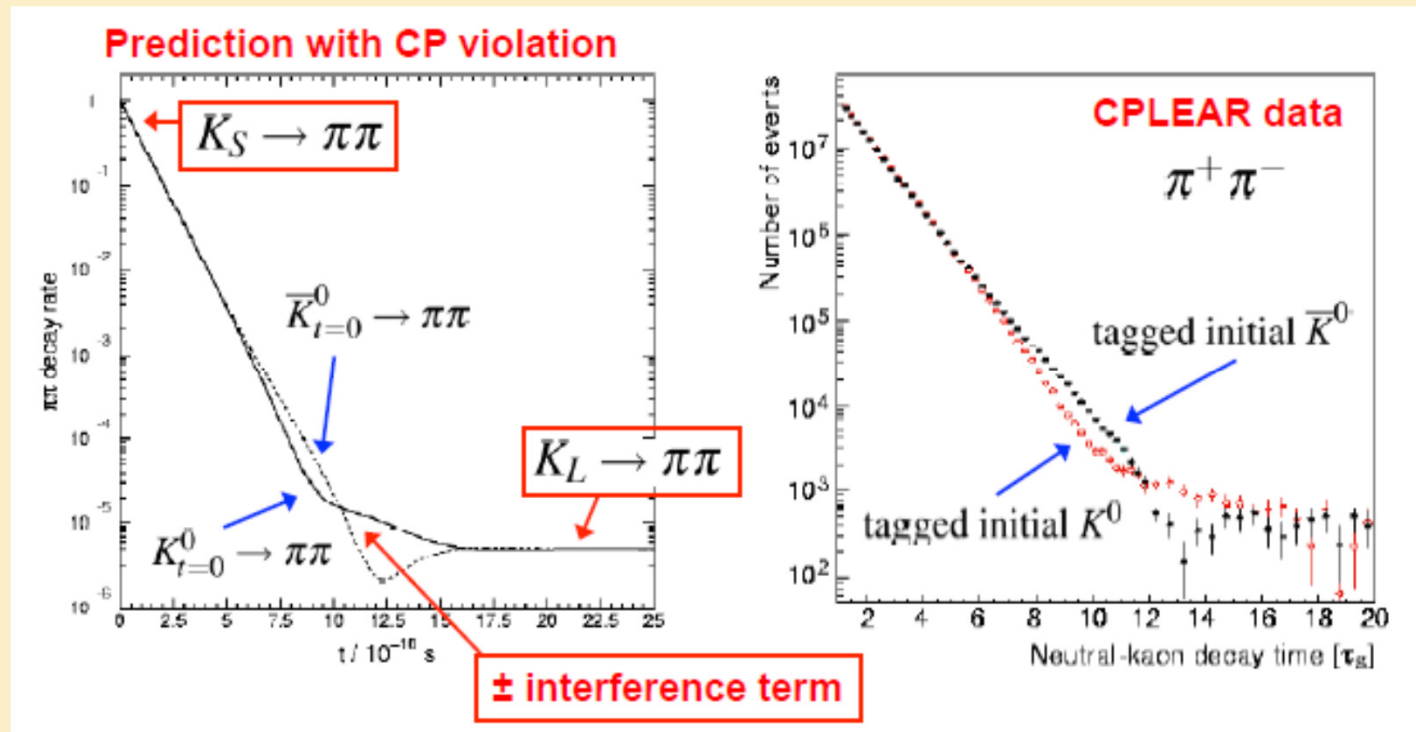

K CP Violation - XIV

Time dependent asymmetry:

$$A(\pi\pi) = \frac{\Gamma(\bar{K}^0) - \Gamma(K^0)}{\Gamma(\bar{K}^0) + \Gamma(K^0)}$$

$$\rightarrow A(\pi\pi) \approx 2\text{Re}(\varepsilon) - 2|\varepsilon| e^{\frac{(\Gamma_S - \Gamma_L)t}{2}} \cos(\Delta mt - \phi)$$

$$\rightarrow \begin{cases} |\varepsilon| = (2.264 \pm 0.035)10^{-3} \\ \varphi = (43.19 \pm 0.073)^\circ \\ \Delta m = (3.4852 \pm 0.013)10^{-15} \text{ GeV} \end{cases}$$

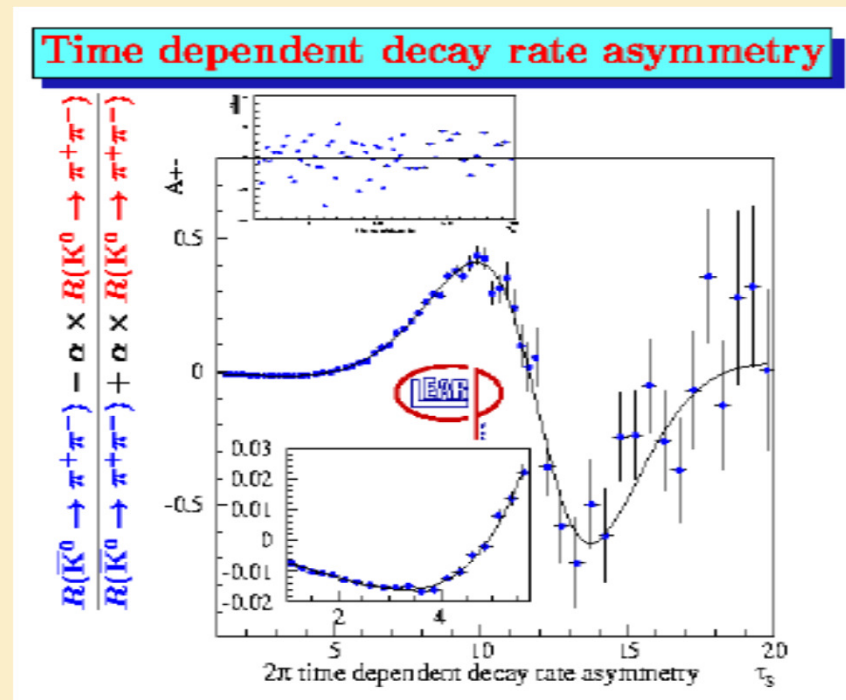

K *CP* Violation - XV

CP violation in 3π decays

Expect, by swapping $K_S \leftrightarrow K_L$:

$$I(K^0; t) = \frac{N'}{2} (1 - 2\text{Re}(\varepsilon)) \left[e^{-\Gamma_L t} + |\varepsilon|^2 e^{-\Gamma_S t} + 2|\varepsilon| e^{-\frac{\Gamma_L + \Gamma_S}{2} t} \cos(\Delta m t - \varphi) \right]$$

Very different experimental conditions as compared to 2π :

Lots of *CP* conserving 3π decays from K_L component of the beam

(Compare: No *CP* conserving 2π from K_S component, which just dies out at large distance)

→ Measurement difficult, large errors

K CP Violation - XVI

Summary of decay rates (CP violated)

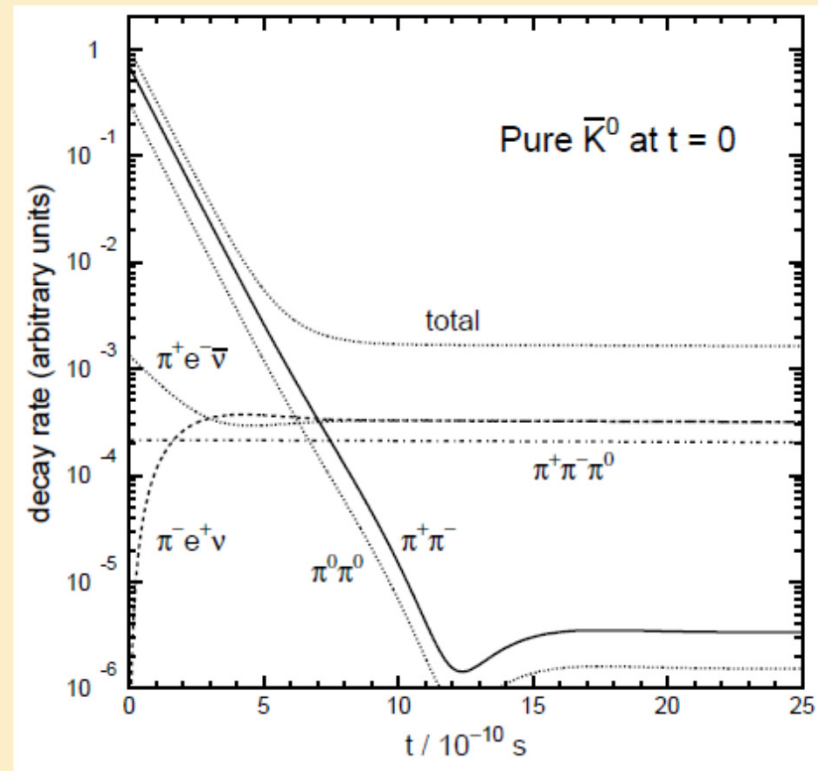
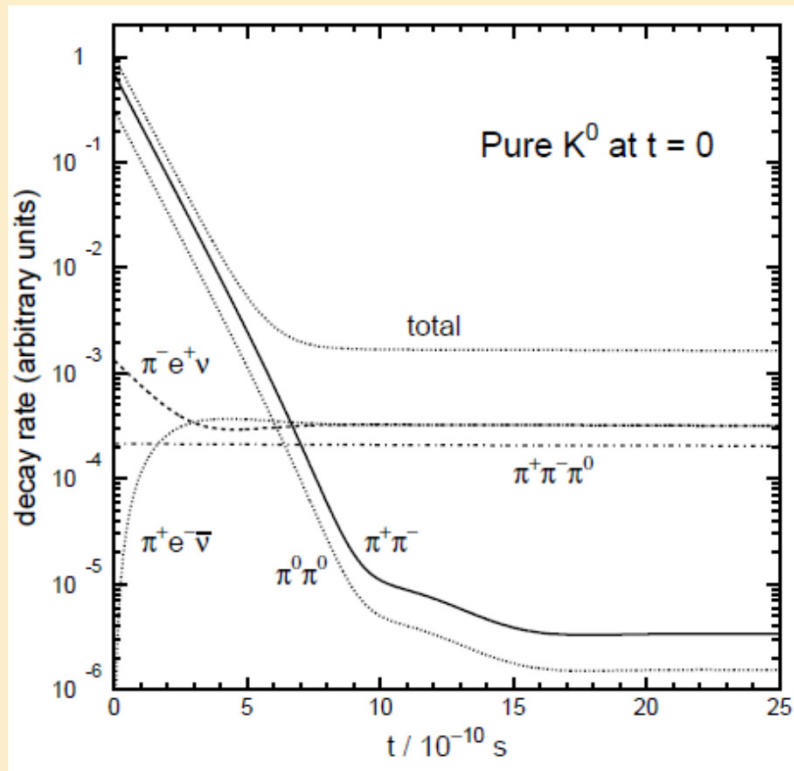

K^0, CPT Tests - I

From previous conclusions on CP violation:

$$R_- = \Gamma(K_{t=0}^0 \rightarrow \pi^+ e^- \bar{\nu}_e) = N(1 - 4\text{Re}\varepsilon) \frac{1}{4} \left[e^{-\Gamma_S t} + e^{-\Gamma_L t} - 2e^{-\frac{\Gamma_S + \Gamma_L}{2} t} \cos \Delta m t \right]$$

$$\bar{R}_+ = \Gamma(\bar{K}_{t=0}^0 \rightarrow \pi^- e^+ \nu_e) = N(1 + 4\text{Re}\varepsilon) \frac{1}{4} \left[e^{-\Gamma_S t} + e^{-\Gamma_L t} - 2e^{-\frac{\Gamma_S + \Gamma_L}{2} t} \cos \Delta m t \right]$$

$$\rightarrow \Gamma(K_{t=0}^0 \rightarrow \bar{K}^0) \neq \Gamma(\bar{K}_{t=0}^0 \rightarrow K^0)$$

\rightarrow Amplitude of direct process \neq Amplitude of reverse process

\rightarrow CP violation \leftrightarrow *Time Reversal* violation

To be expected if CPT is a good symmetry

Define T asymmetry:

$$A_T = \frac{\Gamma(\bar{K}_{t=0}^0 \rightarrow K^0) - \Gamma(K_{t=0}^0 \rightarrow \bar{K}^0)}{\Gamma(\bar{K}_{t=0}^0 \rightarrow K^0) + \Gamma(K_{t=0}^0 \rightarrow \bar{K}^0)}$$

K T, CPT Tests - II

Measure by taking semileptonic:

$$A_T = \frac{\Gamma(\bar{K}_{t=0}^0 \rightarrow \pi^- e^+ \nu_e) - \Gamma(K_{t=0}^0 \rightarrow \pi^+ e^- \bar{\nu}_e)}{\Gamma(\bar{K}_{t=0}^0 \rightarrow \pi^- e^+ \nu_e) + \Gamma(K_{t=0}^0 \rightarrow \pi^+ e^- \bar{\nu}_e)}$$

$$A_T \approx 4 \operatorname{Re}(\varepsilon) = 4|\varepsilon| \cos \phi \text{ Time independent constant}$$

→ Expect from $\pi\pi$ CP violation

$$A_T \approx 6.6 \cdot 10^{-3}$$

Measure:

$$A_T = (6.2 \pm 1.7) \cdot 10^{-3}$$

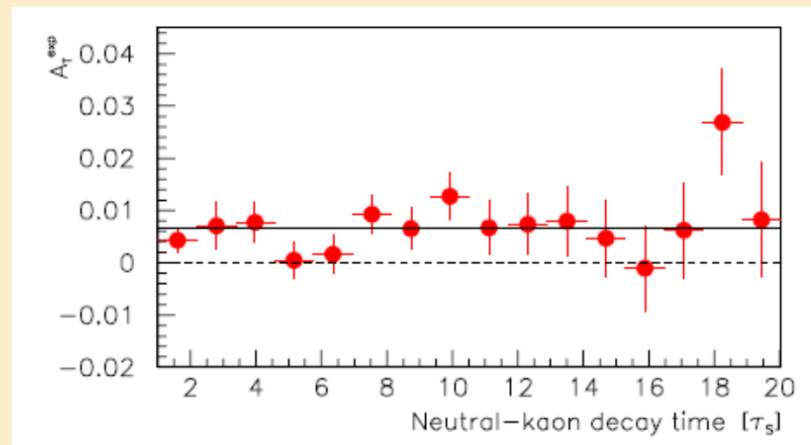

K T , CPT Tests - III

Semileptonic decays also used to test CPT

Simple test:

$$\Gamma(K^0 \rightarrow K^0) = \Gamma(\bar{K}^0 \rightarrow \bar{K}^0)$$

Define CPT asymmetry :

$$A_{CPT} = \frac{\Gamma(K^0 \rightarrow K^0) - \Gamma(\bar{K}^0 \rightarrow \bar{K}^0)}{\Gamma(K^0 \rightarrow K^0) + \Gamma(\bar{K}^0 \rightarrow \bar{K}^0)}$$

Measure by:

$$A_{CPT} = \frac{\Gamma(K_{t=0}^0 \rightarrow \pi^- e^+ \nu_e) - \Gamma(\bar{K}_{t=0}^0 \rightarrow \pi^+ e^- \bar{\nu}_e)}{\Gamma(K_{t=0}^0 \rightarrow \pi^- e^+ \nu_e) + \Gamma(\bar{K}_{t=0}^0 \rightarrow \pi^+ e^- \bar{\nu}_e)}$$

K T, CPT Tests - IV

Since:

$$\Gamma(K_{t=0}^0 \rightarrow \pi^- e^+ \nu_e) = N \frac{1}{4} \left[e^{-\Gamma_S t} + e^{-\Gamma_L t} + 2e^{-\frac{\Gamma_S + \Gamma_L}{2} t} \cos \Delta m t \right]$$

$$\Gamma(\bar{K}_{t=0}^0 \rightarrow \pi^+ e^- \bar{\nu}_e) = N \frac{1}{4} \left[e^{-\Gamma_S t} + e^{-\Gamma_L t} + 2e^{-\frac{\Gamma_S + \Gamma_L}{2} t} \cos \Delta m t \right]$$

→ Expect:

$A_{CPT} = 0$, t independent

Measure:

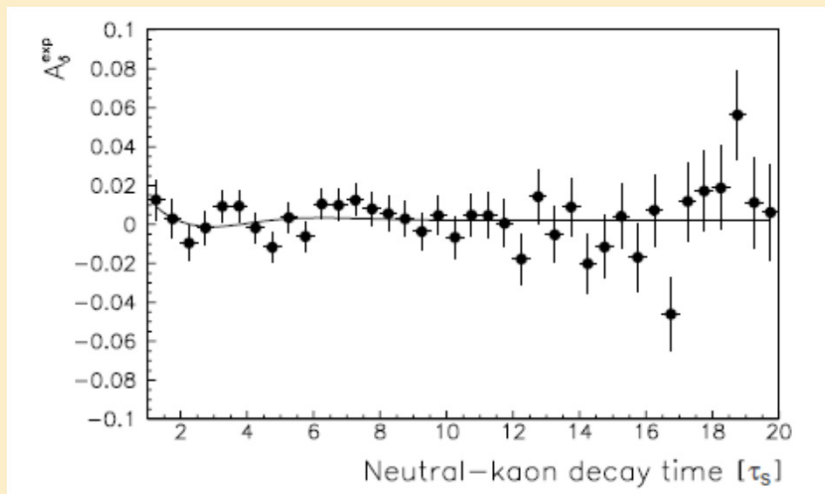

K Direct CP Violation - I

Another side of \mathcal{CP} : K^0 decays CP violating

→ Direct \mathcal{CP}

Amplitude ratios :

$$\eta_{+-} = \frac{\langle \pi^+ \pi^- | T | K_L^0 \rangle}{\langle \pi^+ \pi^- | T | K_S^0 \rangle} = |\eta_{+-}| e^{i\phi_{+-}}, \quad \eta_{00} = \frac{\langle \pi^0 \pi^0 | T | K_L^0 \rangle}{\langle \pi^0 \pi^0 | T | K_S^0 \rangle} = |\eta_{00}| e^{i\phi_{00}}$$

In order to relate η, ϕ parameters to ϵ, ϵ'

a) Decompose 2π states into isospin eigenstates:

$$\begin{cases} \langle \pi^+ \pi^- | = \frac{1}{\sqrt{3}} \langle I=2 | + \sqrt{\frac{2}{3}} \langle I=0 | \\ \langle \pi^0 \pi^0 | = \sqrt{\frac{2}{3}} \langle I=2 | - \frac{1}{\sqrt{3}} \langle I=0 | \end{cases} \quad I=1 \text{ absent due to Bose statistics of } \pi\text{'s in a } S\text{-wave}$$

K Direct CP Violation - II

Full 2π states should include proper phase factors
originating from S -wave $\pi\pi$ scattering

$$\langle \pi^+ \pi^- | = \frac{1}{\sqrt{3}} \langle 2 | e^{i\delta_2} + \sqrt{\frac{2}{3}} \langle 0 | e^{i\delta_0}$$

$$\langle \pi^0 \pi^0 | = \sqrt{\frac{2}{3}} \langle 2 | e^{i\delta_2} - \frac{1}{\sqrt{3}} \langle 0 | e^{i\delta_0}$$

Define decay amplitudes into isospin states:

$$A_0 = \langle 0 | H_w | K^0 \rangle$$

$$A_2 = \langle 2 | H_w | K^0 \rangle$$

K Direct CP Violation - III

$$CP|\pi\pi\rangle = +1 \rightarrow CPT|0\rangle = \langle 0|, CPT|2\rangle = \langle 2|$$

$$CP|K^0\rangle = -|\bar{K}^0\rangle \rightarrow CPT|K^0\rangle = -\langle \bar{K}^0|$$

$$[H_w, CPT] = 0$$

$$\rightarrow \begin{cases} \langle 0|H_w|\bar{K}^0\rangle \xrightarrow{CPT} -\langle K^0|H_w|0\rangle = -A_0^* \\ \langle 2|H_w|\bar{K}^0\rangle \xrightarrow{CPT} -\langle K^0|H_w|2\rangle = -A_2^* \end{cases}$$

$$|K_L^0\rangle = \frac{1}{\sqrt{2(1+|\varepsilon|^2)}} \left[(1+\varepsilon)|K^0\rangle + (1-\varepsilon)|\bar{K}^0\rangle \right]$$

$$|K_S^0\rangle = \frac{1}{\sqrt{2(1+|\varepsilon|^2)}} \left[(1+\varepsilon)|K^0\rangle - (1-\varepsilon)|\bar{K}^0\rangle \right]$$

K Direct CP Violation - IV

Transition matrix elements:

$$\langle \pi^+ \pi^- | H | K_L^0 \rangle = \frac{2}{\sqrt{3}} \frac{1}{\sqrt{2(1+|\epsilon|^2)}} \epsilon \left[\text{Re } A_2 e^{i\delta_2} + \sqrt{2} A_0 e^{i\delta_0} \right] + \text{Im } A_2 e^{i\delta_2}$$

$$\langle \pi^+ \pi^- | H | K_S^0 \rangle = \frac{2}{\sqrt{3}} \frac{1}{\sqrt{2(1+|\epsilon|^2)}} \left[\text{Re } A_2 e^{i\delta_2} + \sqrt{2} A_0 e^{i\delta_0} + \epsilon \text{Im } A_2 e^{i\delta_2} \right]$$

$$\langle \pi^0 \pi^0 | H | K_L^0 \rangle = \frac{2}{\sqrt{3}} \frac{1}{\sqrt{2(1+|\epsilon|^2)}} \epsilon \left[\sqrt{2} \text{Re } A_2 e^{i\delta_2} - A_0 e^{i\delta_0} \right] + \sqrt{2} \text{Im } A_2 e^{i\delta_2}$$

$$\langle \pi^0 \pi^0 | H | K_S^0 \rangle = \frac{2}{\sqrt{3}} \frac{1}{\sqrt{2(1+|\epsilon|^2)}} \left[\sqrt{2} \text{Re } A_2 e^{i\delta_2} - A_0 e^{i\delta_0} + \epsilon \sqrt{2} \text{Im } A_2 e^{i\delta_2} \right]$$

After some complex algebra:

$$\eta_{+-} = \frac{\langle \pi^+ \pi^- | T | K_L^0 \rangle}{\langle \pi^+ \pi^- | T | K_S^0 \rangle} \simeq \epsilon + \underbrace{\frac{1}{\sqrt{2}} \frac{\text{Im } A_2}{A_0} e^{i(\delta_2 - \delta_0)}}_{\epsilon'} = \epsilon + \epsilon'$$

$$\eta_{00} = \frac{\langle \pi^0 \pi^0 | T | K_L^0 \rangle}{\langle \pi^0 \pi^0 | T | K_S^0 \rangle} \simeq \epsilon - \underbrace{\sqrt{2} \frac{\text{Im } A_2}{A_0} e^{i(\delta_2 - \delta_0)}}_{2\epsilon'} = \epsilon - 2\epsilon'$$

K Direct CP Violation - V

Double ratio magic:

$$\eta_{+-} = \frac{\langle \pi^+ \pi^- | T | K_L^0 \rangle}{\langle \pi^+ \pi^- | T | K_S^0 \rangle} \simeq \varepsilon + \varepsilon'$$

$$\eta_{00} = \frac{\langle \pi^0 \pi^0 | T | K_L^0 \rangle}{\langle \pi^0 \pi^0 | T | K_S^0 \rangle} \simeq \varepsilon - 2\varepsilon'$$

$$\rightarrow \left| \frac{\eta_{00}}{\eta_{+-}} \right|^2 \simeq \frac{|\varepsilon - 2\varepsilon'|^2}{|\varepsilon + \varepsilon'|^2} = \frac{(\varepsilon - 2\varepsilon')(\varepsilon - 2\varepsilon')^*}{(\varepsilon + \varepsilon')(\varepsilon + \varepsilon')^*} \simeq \frac{|\varepsilon|^2 - 4\text{Re}(\varepsilon'\varepsilon)}{|\varepsilon|^2 + 2\text{Re}(\varepsilon'\varepsilon)}$$

$$\rightarrow \left| \frac{\eta_{00}}{\eta_{+-}} \right|^2 \approx \frac{1 - 4 \frac{\text{Re}(\varepsilon'\varepsilon)}{|\varepsilon|^2}}{1 + 2 \frac{\text{Re}(\varepsilon'\varepsilon)}{|\varepsilon|^2}} \approx \left[1 - 2 \frac{\text{Re}(\varepsilon'\varepsilon)}{|\varepsilon|^2} \right] \left[1 - 4 \frac{\text{Re}(\varepsilon'\varepsilon)}{|\varepsilon|^2} \right] \approx 1 - 6 \frac{\text{Re}(\varepsilon'\varepsilon)}{|\varepsilon|^2}$$

$$\rightarrow \left| \frac{\eta_{00}}{\eta_{+-}} \right|^2 = \frac{N_L^{00}}{N_S^{00}} \frac{N_L^{+-}}{N_S^{+-}} \approx 1 - 6 \text{Re} \frac{(\varepsilon')}{|\varepsilon|}$$

K Direct CP Violation - VI

Actually a very important question:

Does weak interaction violate CP ?

$\varepsilon' \neq 0$ yes

$\varepsilon' = 0$ don't know

'80s:

$$\operatorname{Re}\left(\frac{\varepsilon'}{\varepsilon}\right) = (23.0 \pm 6.5) \times 10^{-4} (NA31) \quad >3\sigma$$

$$\operatorname{Re}\left(\frac{\varepsilon'}{\varepsilon}\right) = (7.4 \pm 5.9) \times 10^{-4} (E731) \quad \sim 1.5\sigma$$

Mostly systematics

'90s:

$$\operatorname{Re}\left(\frac{\varepsilon'}{\varepsilon}\right) = (15.3 \pm 2.6) \times 10^{-4} (NA48) \quad \sim 6\sigma$$

$$\operatorname{Re}\left(\frac{\varepsilon'}{\varepsilon}\right) = (20.7 \pm 2.8) \times 10^{-4} (KTEV) \quad >7\sigma$$

K Direct CP Violation - VII

NA48 technique

- Employ two almost collinear neutral beams
- Collect the four decay modes simultaneously, in the same detector and from the same decay region
- Keep the acceptance correction small by weighting the K_L events according to the ratio of K_S/K_L decay intensities as a function of proper time
- Distinguish K_S and K_L events by tagging the protons upstream of the K_S target
- Use precise and stable liquid krypton (LKr) calorimetry to control the relative momentum scale

K Direct CP Violation - VIII

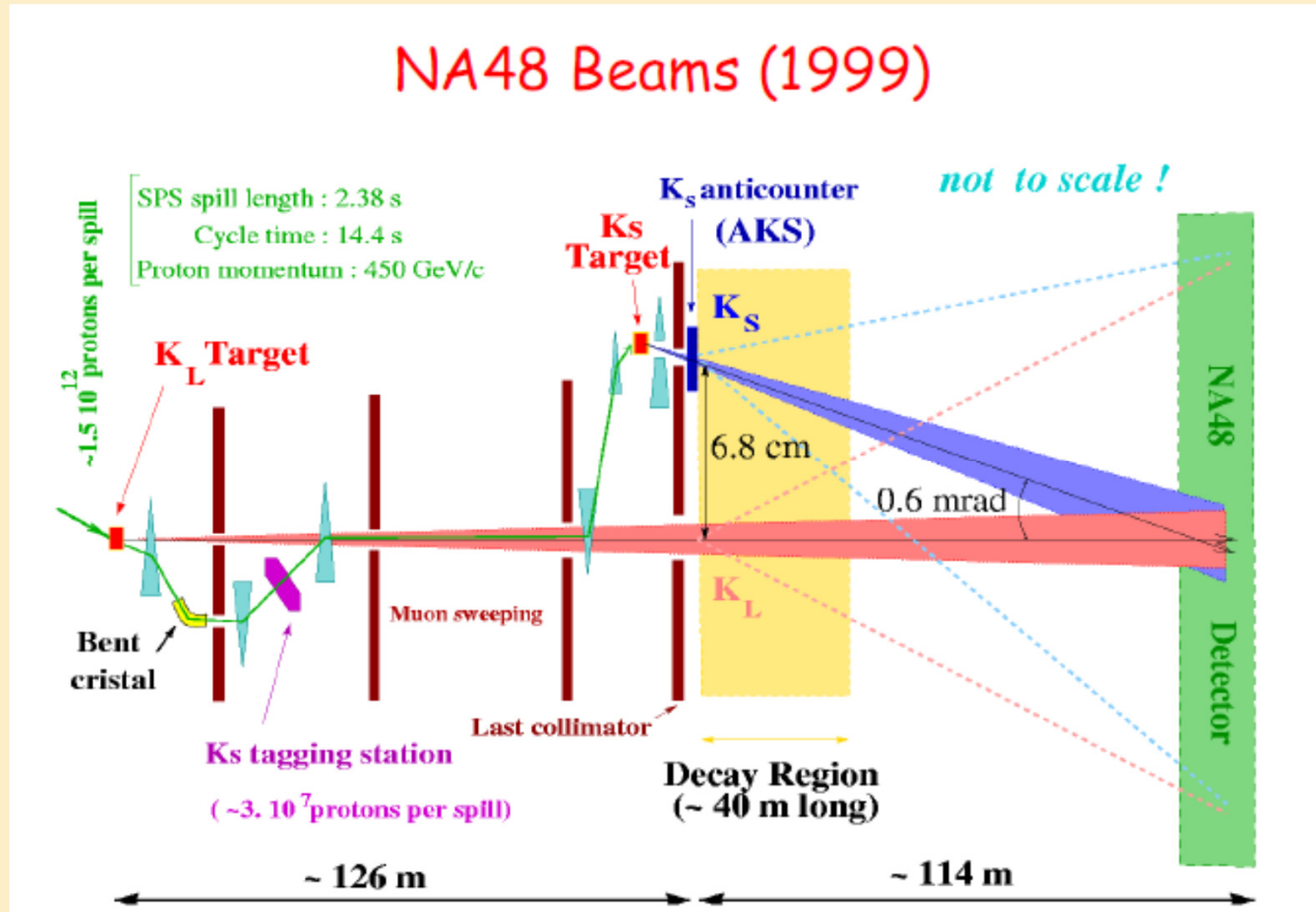

K Direct CP Violation - IX

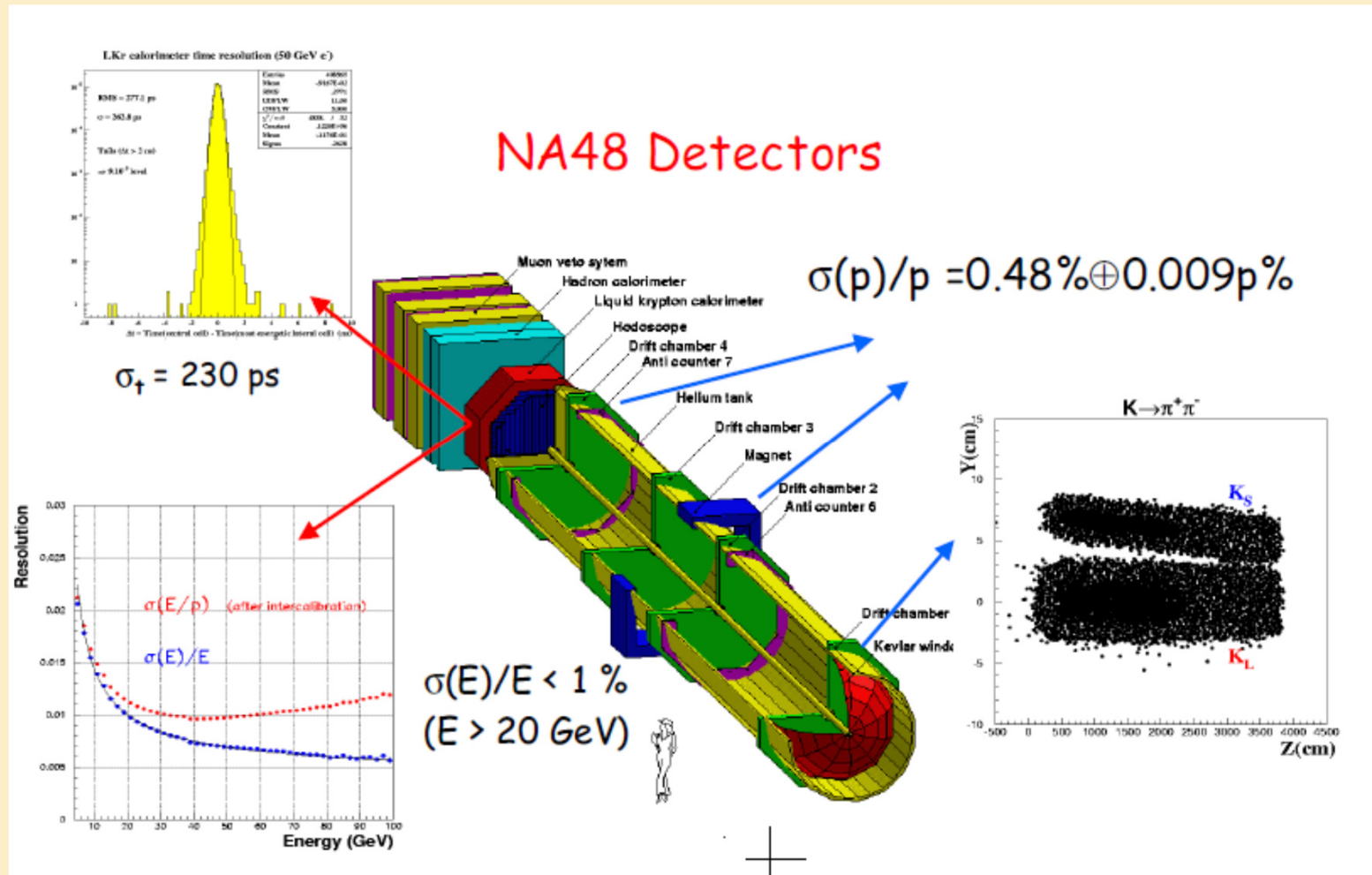

K Direct CP Violation - X

Systematics Checks and Result

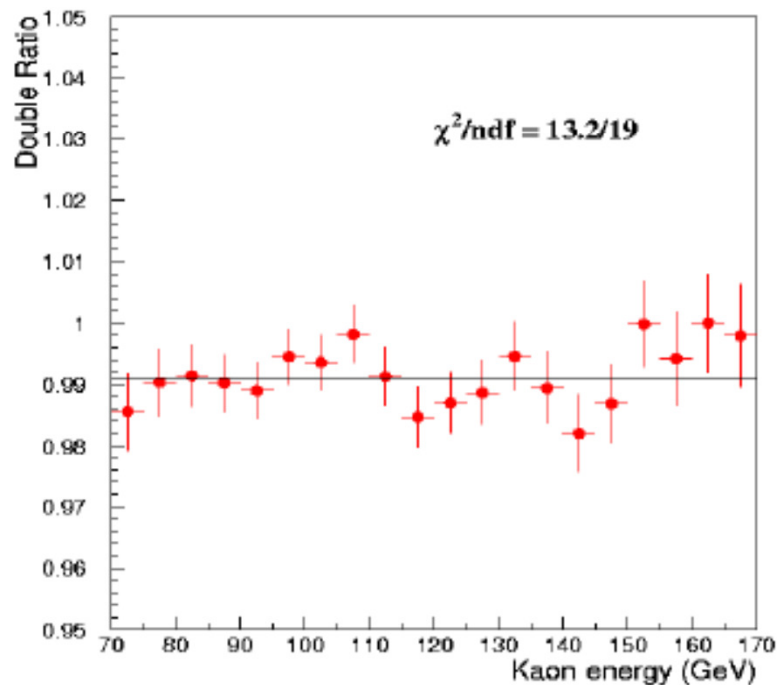

R stability against cut variations

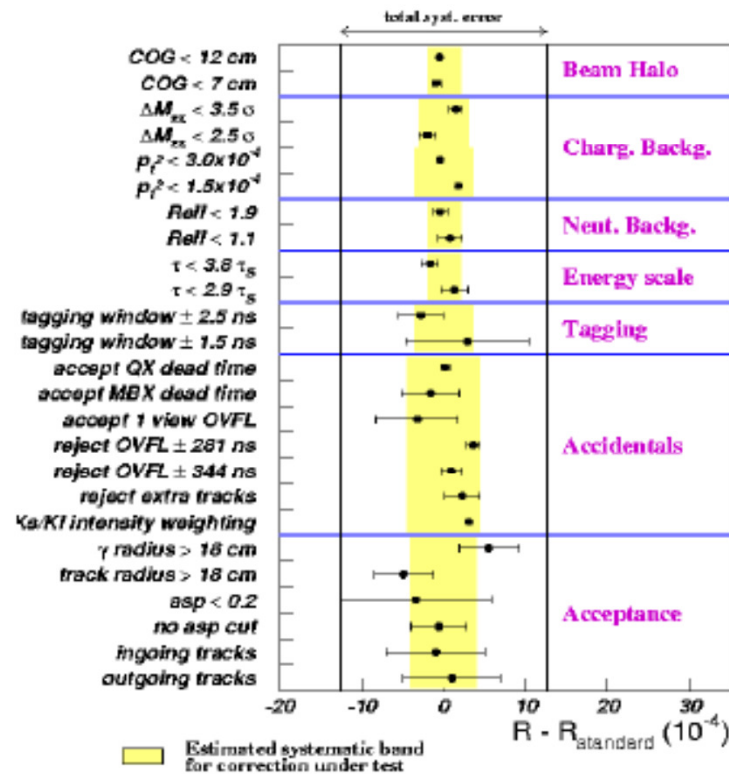

Mixing and Oscillations - I

Two-state system: Electron in a magnetic field \mathbf{B} along \hat{z}

$$H = -\boldsymbol{\mu} \cdot \mathbf{B} = \frac{1}{2} a \boldsymbol{\sigma} \cdot \mathbf{B} \quad \mathbf{B} = B \hat{k}, \quad \boldsymbol{\sigma} = (\sigma_x, \sigma_y, \sigma_z): \text{Pauli spin matrices}$$

$$\rightarrow H = \frac{1}{2} a \sigma_z B = \begin{pmatrix} \frac{1}{2} a B & 0 \\ 0 & -\frac{1}{2} a B \end{pmatrix} = \begin{pmatrix} +E & 0 \\ 0 & -E \end{pmatrix}$$

2 state system: Choose as base states

$$|+\rangle \equiv \begin{pmatrix} 1 \\ 0 \end{pmatrix}, |-\rangle \equiv \begin{pmatrix} 0 \\ 1 \end{pmatrix} \quad \text{Eigenstates of } \sigma_z \rightarrow \text{Generic state: } |\psi\rangle = \begin{pmatrix} \psi_+ \\ \psi_- \end{pmatrix} \rightarrow \sigma_z |\psi\rangle = \begin{pmatrix} \psi_+ \\ -\psi_- \end{pmatrix}$$

Schrodinger equation:

$$i\hbar \frac{\partial |\psi\rangle}{\partial t} = H |\psi\rangle \rightarrow |\psi(t)\rangle = e^{-i\frac{Ht}{\hbar}} |\psi\rangle = e^{-i\frac{aB}{2\hbar} t \sigma_z} |\psi\rangle \rightarrow i\hbar \frac{\partial}{\partial t} \begin{pmatrix} \psi_+ \\ \psi_- \end{pmatrix} = \frac{1}{2} a B \sigma_z \begin{pmatrix} \psi_+ \\ \psi_- \end{pmatrix} = \frac{1}{2} a B \begin{pmatrix} \psi_+ \\ -\psi_- \end{pmatrix}$$

Uncoupled equations:

$$\rightarrow \begin{cases} i\hbar \frac{\partial \psi_+}{\partial t} = \frac{1}{2} a B \psi_+ \\ i\hbar \frac{\partial \psi_-}{\partial t} = -\frac{1}{2} a B \psi_- \end{cases} \rightarrow \begin{cases} \psi_+(t) = A_+ e^{-i\frac{aB}{2\hbar} t} \\ \psi_-(t) = A_- e^{+i\frac{aB}{2\hbar} t} \end{cases}, \quad |A_+|^2 + |A_-|^2 = 1 \rightarrow \begin{cases} |+,t\rangle = \begin{pmatrix} \psi_+(t) \\ 0 \end{pmatrix} \\ |-,t\rangle = \begin{pmatrix} 0 \\ \psi_-(t) \end{pmatrix} \end{cases} \quad \text{Stationary states}$$

Mixing and Oscillations - II

Introduce another \mathbf{B} component along x :

$$\mathbf{B} = B\hat{\mathbf{k}} + B'\hat{\mathbf{i}}$$

$$H = -\boldsymbol{\mu} \cdot \mathbf{B} = \frac{1}{2}a\boldsymbol{\sigma} \cdot \mathbf{B} = \frac{1}{2}a(\sigma_z B + \sigma_x B')$$

$$\rightarrow H = \begin{pmatrix} \frac{1}{2}aB & 0 \\ 0 & -\frac{1}{2}aB \end{pmatrix} + \begin{pmatrix} 0 & \frac{1}{2}aB' \\ \frac{1}{2}aB' & 0 \end{pmatrix} = \begin{pmatrix} +E & E' \\ E' & -E \end{pmatrix}$$

$$\rightarrow i\hbar \frac{\partial}{\partial t} \begin{pmatrix} \psi_+ \\ \psi_- \end{pmatrix} = \frac{1}{2}a(B\sigma_z + B'\sigma_x) \begin{pmatrix} \psi_+ \\ \psi_- \end{pmatrix} = \frac{1}{2}a \left[B \begin{pmatrix} \psi_+ \\ -\psi_- \end{pmatrix} + B' \begin{pmatrix} \psi_- \\ \psi_+ \end{pmatrix} \right]$$

Coupled equations:

$$\rightarrow \begin{cases} i\hbar \frac{\partial \psi_+}{\partial t} = \frac{1}{2}aB\psi_+ + aB'\psi_- \\ i\hbar \frac{\partial \psi_-}{\partial t} = -\frac{1}{2}aB\psi_- + aB'\psi_+ \end{cases} \rightarrow \begin{cases} |+,t\rangle \\ |-,t\rangle \end{cases} \text{ Non-stationary states}$$

Mixing and Oscillations - III

Build a phenomenological framework suitable to describe flavor oscillations

Use symbol M^0 for neutral, flavored mesons: Most of the formalism suitable for K^0, D^0, B^0, B_s^0

Neutral meson time evolution: Two-state system

$$|M^0\rangle = \begin{pmatrix} 1 \\ 0 \end{pmatrix}, |\bar{M}^0\rangle = \begin{pmatrix} 0 \\ 1 \end{pmatrix}$$

$$i \frac{\partial}{\partial t} \psi = H \psi \quad \text{Schrodinger equation}$$

$$\psi(t) = a(t)|M^0\rangle + b(t)|\bar{M}^0\rangle \equiv \begin{pmatrix} a(t) \\ b(t) \end{pmatrix} \quad \text{Two-component state vector}$$

Just free evolution for both components, no decay:

$$H = \underbrace{\begin{pmatrix} M & 0 \\ 0 & M \end{pmatrix}}_{\text{hermitian}} \quad \text{Effective Hamiltonian, } M = \text{mass}$$

Free evolution for both components, with decay:

$$H = \underbrace{\begin{pmatrix} M & 0 \\ 0 & M \end{pmatrix}}_{\text{hermitian}} - \frac{i}{2} \underbrace{\begin{pmatrix} \Gamma & 0 \\ 0 & \Gamma \end{pmatrix}}_{\text{hermitian}}, \quad \Gamma = \text{total decay width}$$

Mixing and Oscillations - IV

Observe:

$$H^\dagger = \begin{pmatrix} M & 0 \\ 0 & M \end{pmatrix}^\dagger + \frac{i}{2} \begin{pmatrix} \Gamma & 0 \\ 0 & \Gamma \end{pmatrix}^\dagger = \begin{pmatrix} M & 0 \\ 0 & M \end{pmatrix} + \frac{i}{2} \begin{pmatrix} \Gamma & 0 \\ 0 & \Gamma \end{pmatrix} \neq H$$

$\rightarrow H$ non-Hermitian $\rightarrow e^{-iHt}$ non-unitary \rightarrow State norm not conserved: Decreasing $\leftrightarrow \Gamma > 0$

$$H = \underbrace{\begin{pmatrix} M & A \\ B & M \end{pmatrix}}_{\text{hermitian}} - \frac{i}{2} \underbrace{\begin{pmatrix} \Gamma & C \\ D & \Gamma \end{pmatrix}}_{\text{hermitian}} \quad \text{Include mixing}$$

$$\begin{pmatrix} M & A \\ B & M \end{pmatrix}^\dagger = \begin{pmatrix} M & A \\ B & M \end{pmatrix} \rightarrow \begin{pmatrix} M & B^* \\ A^* & M \end{pmatrix} = \begin{pmatrix} M & A \\ B & M \end{pmatrix} \rightarrow A^* = B, \text{ same for } \Gamma$$

$$\rightarrow H = \underbrace{\begin{pmatrix} M & M_{12} \\ M_{12}^* & M \end{pmatrix}}_{\text{hermitian}} - \frac{i}{2} \underbrace{\begin{pmatrix} \Gamma & \Gamma_{12} \\ \Gamma_{12}^* & \Gamma \end{pmatrix}}_{\text{hermitian}}$$

$$\rightarrow i \frac{\partial}{\partial t} \psi(t) = \begin{pmatrix} M - \frac{i}{2} \Gamma & M_{12} - \frac{i}{2} \Gamma_{12} \\ M_{12}^* - \frac{i}{2} \Gamma_{12}^* & M - \frac{i}{2} \Gamma \end{pmatrix} \psi(t)$$

Mixing and Oscillations - V

Eigenvalues:

$$\text{Define } F \equiv \text{Re } F + i \text{Im } F = \sqrt{\left(M_{12} - \frac{i}{2}\Gamma_{12}\right)\left(M_{12}^* - \frac{i}{2}\Gamma_{12}^*\right)}$$

$$\begin{vmatrix} M - \frac{i}{2}\Gamma - \lambda & M_{12} - \frac{i}{2}\Gamma_{12} \\ M_{12}^* - \frac{i}{2}\Gamma_{12}^* & M - \frac{i}{2}\Gamma - \lambda \end{vmatrix} = 0 \rightarrow \begin{aligned} \lambda_1 &\equiv m_1 - i\frac{\Gamma_1}{2} = M - i\frac{\Gamma}{2} - F \\ \lambda_2 &\equiv m_2 - i\frac{\Gamma_2}{2} = M - i\frac{\Gamma}{2} + F \end{aligned}$$

$$\rightarrow \begin{cases} m_1 - i\frac{\Gamma_1}{2} = M - \text{Re}(F) - i\left(\frac{\Gamma}{2} + \text{Im}(F)\right) \\ m_2 - i\frac{\Gamma_2}{2} = M + \text{Re}(F) - i\left(\frac{\Gamma}{2} - \text{Im}(F)\right) \end{cases}$$

$$\rightarrow \begin{cases} \Delta m = m_2 - m_1 = 2\text{Re}(F) = 2\text{Re}\sqrt{\left(M_{12} - \frac{i}{2}\Gamma_{12}\right)\left(M_{12}^* - \frac{i}{2}\Gamma_{12}^*\right)} \\ \Delta\Gamma = \Gamma_2 - \Gamma_1 = 4\text{Im}(F) = 4\text{Im}\sqrt{\left(M_{12} - \frac{i}{2}\Gamma_{12}\right)\left(M_{12}^* - \frac{i}{2}\Gamma_{12}^*\right)} \end{cases}$$

Mixing and Oscillations - VI

Eigenvectors:

$$\begin{pmatrix} M - \frac{i}{2}\Gamma & M_{12} - \frac{i}{2}\Gamma_{12} \\ M_{12}^* - \frac{i}{2}\Gamma_{12}^* & M - \frac{i}{2}\Gamma \end{pmatrix} \begin{pmatrix} p \\ q \end{pmatrix} = \lambda_{1,2} \begin{pmatrix} p \\ q \end{pmatrix} \rightarrow \eta \equiv \frac{q}{p} = \sqrt{\frac{M_{12}^* - \frac{i}{2}\Gamma_{12}^*}{M_{12} - \frac{i}{2}\Gamma_{12}}}, |q|^2 + |p|^2 = 1$$

Mass eigenstates, similar to K_S, K_L :

Named "Heavy" and "Light" because for heavy quarks \cong same lifetime

$$\begin{cases} |M_H\rangle = p|M^0\rangle + q|\overline{M^0}\rangle, & m_H = m_1, \Gamma_H = \Gamma_1 \\ |M_L\rangle = p|M^0\rangle - q|\overline{M^0}\rangle, & m_L = m_2, \Gamma_L = \Gamma_2 \end{cases}$$

Flavor eigenstates:

$$\begin{cases} |M^0\rangle = \frac{1}{2p}(|M_H\rangle + |M_L\rangle) \\ |\overline{M^0}\rangle = \frac{1}{2q}(|M_H\rangle - |M_L\rangle) \end{cases}$$

Mixing and Oscillations - VII

Define:

$$\omega_+ = m_H - i\frac{\Gamma_H}{2}, \omega_- = m_L - i\frac{\Gamma_L}{2}$$

Time evolution of mass eigenstates:

$$\begin{cases} |M_H(t)\rangle = e^{-i\omega_+ t} |M_H(0)\rangle \\ |M_L(t)\rangle = e^{-i\omega_- t} |M_L(0)\rangle \end{cases}$$

→ Straightforward free propagation & decay

Observe:

$$\Gamma_H \cong \Gamma_L \rightarrow \tau_H \cong \tau_L$$

Generally true for heavy mesons, due to a large number of decay modes

Mixing and Oscillations - VIII

Time evolution of flavor eigenstates:

Flavor oscillations

$$|M^0(t)\rangle = \frac{1}{2p} \left[|M_H\rangle e^{-i\omega_+ t} + |M_L\rangle e^{-i\omega_- t} \right] = \frac{1}{2p} \left[(|M^0\rangle + \eta |\bar{M}^0\rangle) e^{-i\omega_+ t} + (|M^0\rangle - \eta |\bar{M}^0\rangle) e^{-i\omega_- t} \right]$$

$$|M^0(t)\rangle = \frac{1}{2p} \left[|M^0\rangle \frac{e^{-i\omega_+ t} + e^{-i\omega_- t}}{2} + \eta |\bar{M}^0\rangle \frac{e^{-i\omega_+ t} - e^{-i\omega_- t}}{2} \right]$$

Define: $g_{\pm}(t) = \frac{e^{-i\omega_+ t} \pm e^{-i\omega_- t}}{2}$

$$\rightarrow \begin{cases} |M^0(t)\rangle \propto g_+(t) |M^0\rangle + \frac{q}{p} g_-(t) |\bar{M}^0\rangle \\ |\bar{M}^0(t)\rangle \propto g_+(t) |\bar{M}^0\rangle + \frac{p}{q} g_-(t) |M^0\rangle \end{cases}$$

$$\rightarrow \begin{cases} |M^0(t)\rangle = \frac{1}{\sqrt{1+|\eta|^2}} (g_+(t) |M^0\rangle + \eta g_-(t) |\bar{M}^0\rangle) \\ |\bar{M}^0(t)\rangle = \frac{1}{\sqrt{1+|\eta|^2}} (\eta g_+(t) |\bar{M}^0\rangle + g_-(t) |M^0\rangle) \end{cases}$$

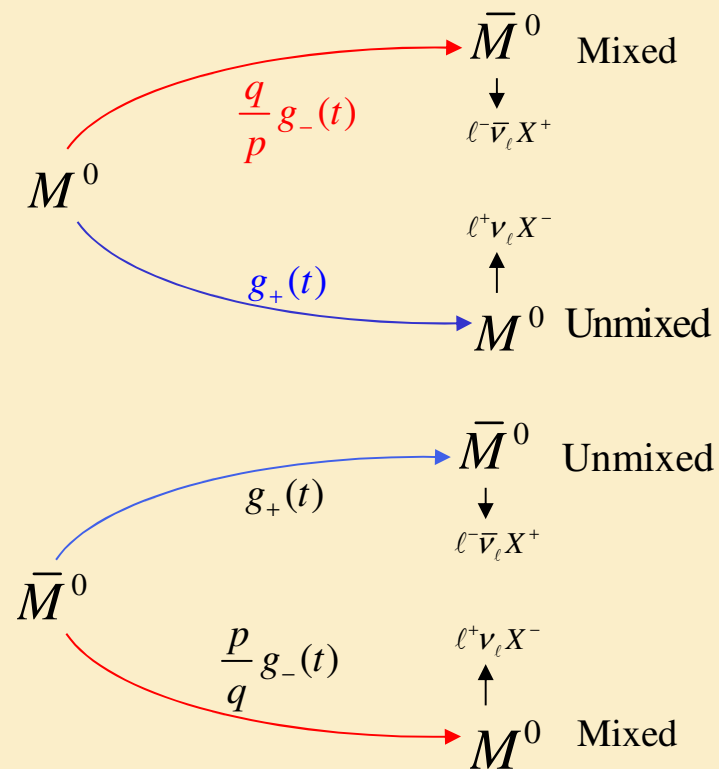

Mixing and Oscillations - IX

Compare different ratios

$$x = \frac{\Delta m}{\Gamma}$$

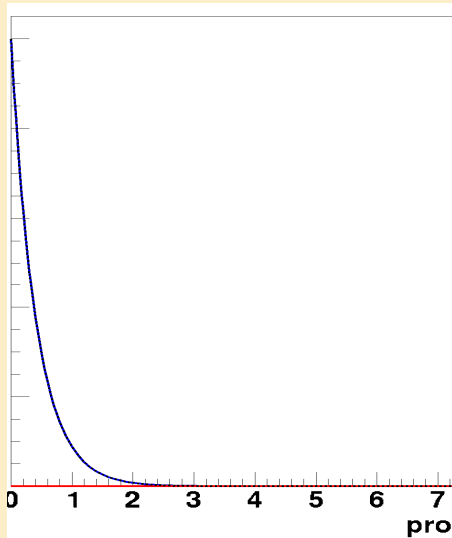

$$x \equiv \frac{\Delta m}{\Gamma} = 0$$

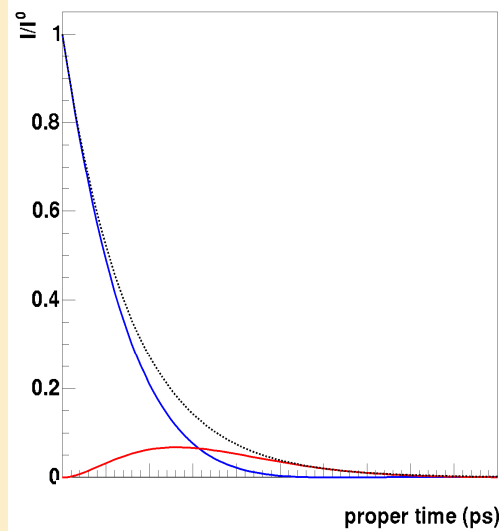

$$x \equiv \frac{\Delta m}{\Gamma} \approx 1$$

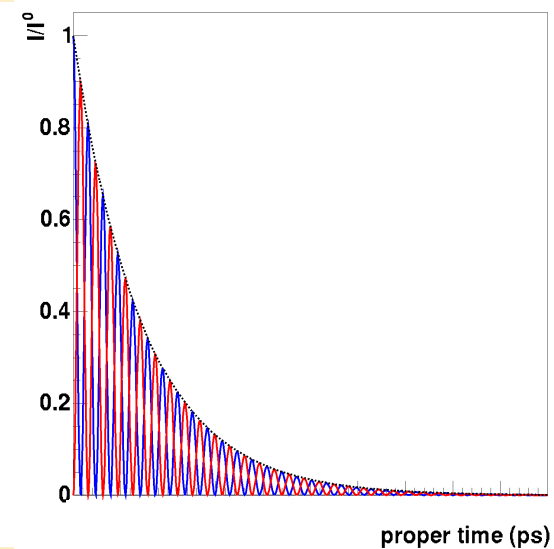

$$x \equiv \frac{\Delta m}{\Gamma} \gg 1$$

CP Violation and SM - I

So far: Phenomenological description \rightarrow ~ Just symmetries

Now: Try to connect to SM

K Mixing : *Box* diagrams

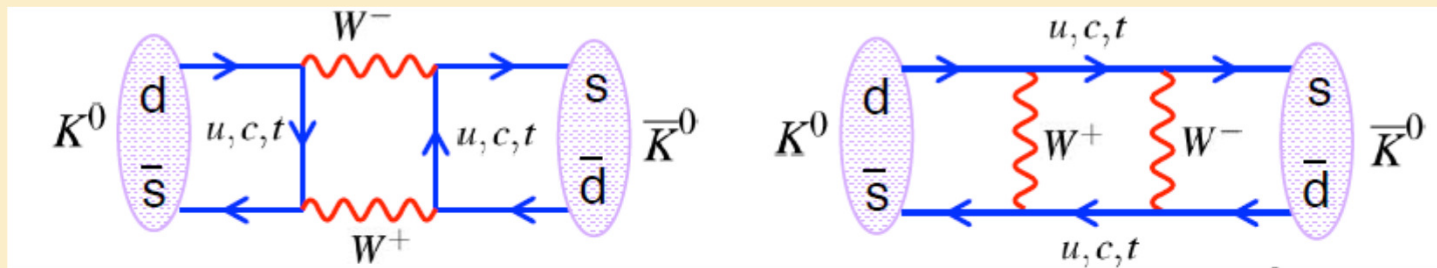

Mass difference between mass eigenstates:

$$\Delta m_K \approx \frac{G_F^2}{3\pi^2} f_K^2 m_K \left| V_{qd} V_{qs}^* V_{q'd} V_{q's}^* \right| m_q m_{q'}, \quad q, q' = u, c, t$$

CP Violation and SM - II

Go to *CKM*, find:

u, u	$\sin^2 \theta_c \cos^2 \theta_c m_u^2$	$\sim 0.048 m_u^2$	$\sim .005$
u, c	$\sin^2 \theta_c \cos^2 \theta_c m_u m_c$	$\sim 0.048 m_u m_c$	$\sim .022$
u, t	$ V_{td} V_{ts} \sin \theta_c \cos \theta_c m_u m_t$	$\sim 0.220 \cdot 4 \cdot 10^{-5} m_u m_t$	$\sim .0005$
c, c	$\sin^2 \theta_c \cos^2 \theta_c m_c^2$	$\sim 0.048 m_c^2$	$\sim .095$
c, t	$ V_{td} V_{ts} \sin \theta_c \cos \theta_c m_c m_t$	$\sim 0.220 \cdot 4 \cdot 10^{-5} m_c m_t$	$\sim .0021$
t, t	$ V_{td} ^2 V_{ts} ^2 m_t^2$	$\sim 1.610 \cdot 10^{-10} m_t^2$	~ 0

→ Diagrams with c quark : Most relevant

CP Violation and SM - III

Just for the fun: Oversimplify, take only charm contribution

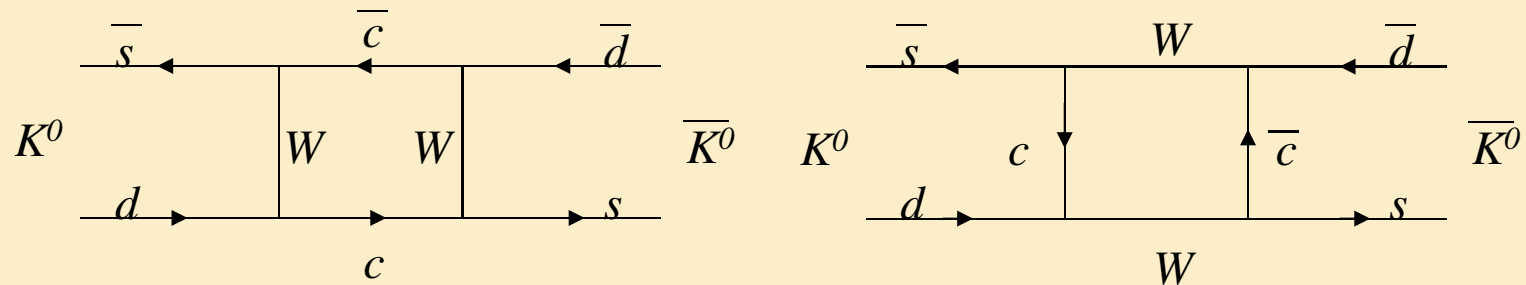

$$A_{box} \propto (V_{cs} V_{cd}^*)^2 m_c^2 \approx (\lambda^2 + i2A^2 \lambda^6 \eta) m_c^2$$

$$|\varepsilon| \approx \frac{\text{Im}(A_{box})}{\text{Re}(A_{box})} \approx \frac{2A^2 \lambda^6 \eta}{\lambda^2} = 2A^2 \lambda^4 \eta$$

$$|\varepsilon| \sim 2 \cdot 0.81 \cdot 0.0025 \cdot 0.343 \sim 1.410^{-3}$$

Not that bad...

CP Violation and SM - IV

Fun again: 2π decays and ε'
 Must take into account two diagrams:

'Tree'

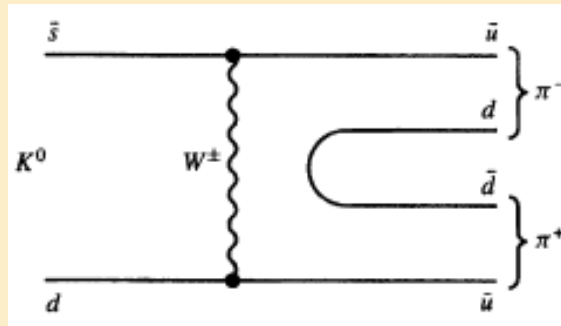

$$\propto |V_{us} V_{ud}|^2 \approx \lambda^2$$

'Penguin'

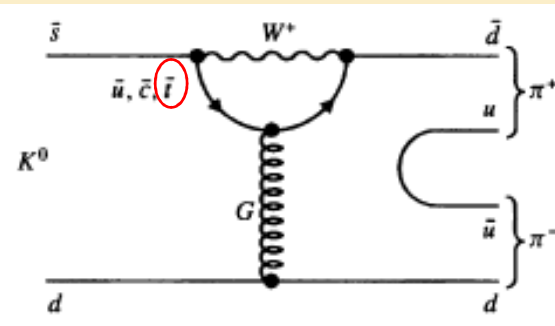

Top dominating:

$$\propto \text{Im}(V_{ts} V_{td}) \approx A^2 \lambda^5 \eta$$

$\varepsilon' \propto$ Interference between the two above $\sim \lambda^2 A^2 \lambda^5 \eta \sim \lambda^7$

$$\rightarrow \frac{\varepsilon'}{\varepsilon} \sim \frac{A^2 \lambda^7 \eta}{2A^2 \lambda^4 \eta} \sim \frac{\lambda^3}{2} \sim 510^{-3} \text{ Not that bad too...}$$

CP Violation and SM - V

Reconsidering box diagrams:

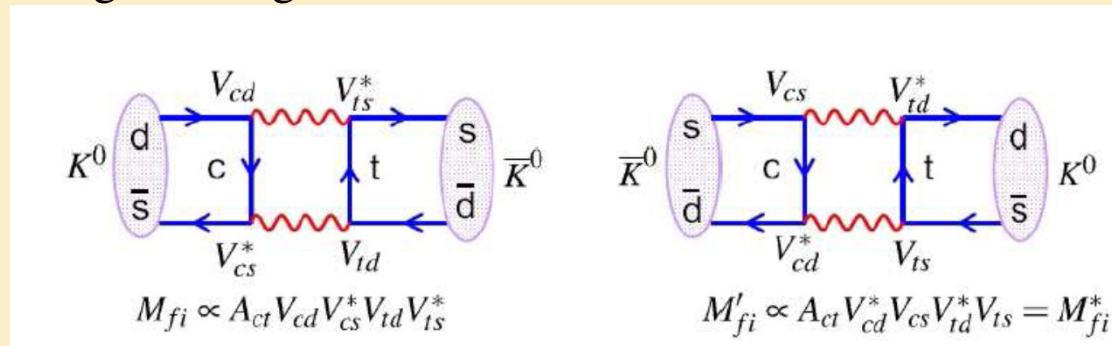

$$\Gamma(K_{t=0}^0 \rightarrow \bar{K}^0) - \Gamma(\bar{K}_{t=0}^0 \rightarrow K^0) \propto M_{fi} - M_{fi}^* = 2\text{Im}(M_{fi})$$

$$A_T \equiv \frac{\Gamma(\bar{K}^0 \rightarrow K^0) - \Gamma(K^0 \rightarrow \bar{K}^0)}{\Gamma(\bar{K}^0 \rightarrow K^0) + \Gamma(K^0 \rightarrow \bar{K}^0)}$$

Remembering:

$$A_T \approx 4\text{Re}(\varepsilon) \rightarrow 4\text{Re}(\varepsilon) \propto 2\text{Im} M_{fi}$$

→ No \mathcal{CP} from mixing unless some CKM elements are complex

CP Violation and SM - VI

Summary about neutral kaons:

Lifetime, width, mass:

$$m_1 \simeq m_2 \rightarrow \Delta m \simeq 4.1 \cdot 10^{-6} \text{ eV}$$

$$\tau_1 \ll \tau_2 \sim 0.09 - 52 \text{ ns}$$

$$\Gamma_2 \ll \Gamma_1 \sim 11.1 \text{ ns}^{-1} \sim 0.038 \cdot 10^{-3} \text{ eV}$$

$$\Gamma = \frac{\Gamma_1 + \Gamma_2}{2} \simeq \frac{\Gamma_1}{2}$$

$$x \equiv \frac{\Delta m}{\Gamma} \sim 0.5, \quad y \equiv \frac{\Delta \Gamma}{2\Gamma} \sim 0.5$$

$$\omega_+ = m_H - i \frac{\Gamma_H}{2}, \quad \omega_- = m_L - i \frac{\Gamma_L}{2}$$

$$\rightarrow g_+(t) = \frac{e^{-i(m_L + \Delta m - i \frac{\Gamma_H}{2})t} + e^{-i(m_L - i \frac{\Gamma_L}{2})t}}{2} = \frac{e^{-im_L t} e^{-\frac{\Gamma_L}{2}t} \left(e^{i\Delta m t} e^{-\frac{\Gamma_H - \Gamma_L}{2}t} + 1 \right)}{2} \approx e^{-imt} \frac{e^{i\Delta m t} e^{-\frac{\Gamma}{2}t} + 1}{2}$$

$$g_-(t) = \frac{e^{-i(m_L + \Delta m - i \frac{\Gamma_H}{2})t} - e^{-i(m_L - i \frac{\Gamma_L}{2})t}}{2} = \frac{e^{-im_L t} e^{-\frac{\Gamma_L}{2}t} \left(e^{i\Delta m t} e^{-\frac{\Gamma_H - \Gamma_L}{2}t} - 1 \right)}{2} \approx e^{-imt} \frac{e^{i\Delta m t} e^{-\frac{\Gamma}{2}t} - 1}{2}$$

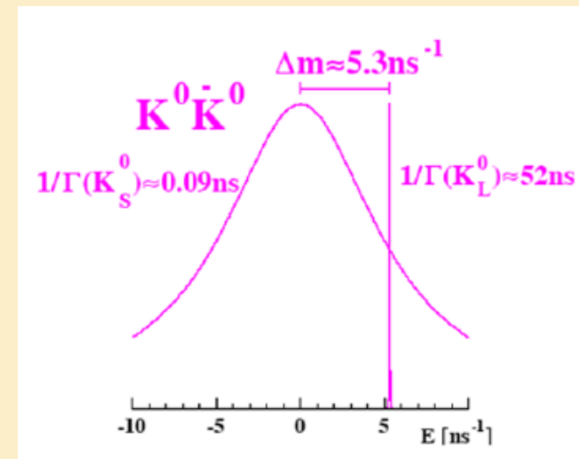

CP Violation and SM - VII

For K : $\Delta\Gamma = \Gamma_S - \Gamma_L \approx \Gamma_S, \left| \frac{q}{p} \right| = |\eta| \neq 1$

$$\left\{ \begin{array}{l} |K^0(t)\rangle = g_+(t)|K^0\rangle + \eta g_-(t)|\bar{K}^0\rangle \approx e^{-imt} \left[\frac{e^{i\Delta mt} e^{-\frac{\Gamma}{2}t} + 1}{2} |K^0\rangle + \eta \frac{e^{i\Delta mt} e^{-\frac{\Gamma}{2}t} - 1}{2} |\bar{K}^0\rangle \right] \\ |\bar{K}^0(t)\rangle = g_+(t)|\bar{K}^0\rangle + \frac{1}{\eta} g_-(t)|K^0\rangle \approx e^{-imt} \left[\frac{e^{i\Delta mt} e^{-\frac{\Gamma}{2}t} + 1}{2} |\bar{K}^0\rangle + \frac{1}{\eta} \frac{e^{i\Delta mt} e^{-\frac{\Gamma}{2}t} - 1}{2} |K^0\rangle \right] \end{array} \right.$$

$$P_{K^0}(K^0, t) = |g_+(t)|^2 = g_+ g_+^* \approx \frac{e^{i\Delta mt} e^{-\frac{\Gamma}{2}t} + 1}{2} \frac{e^{-i\Delta mt} e^{-\frac{\Gamma}{2}t} + 1}{2} = \frac{1}{4} \left(1 + e^{-\frac{\Gamma}{2}t} (1 + 2 \cos \Delta mt) \right)$$

$$P_{K^0}(\bar{K}^0, t) \approx \frac{e^{i\Delta mt} e^{-\frac{\Gamma}{2}t} - 1}{2} \frac{e^{-i\Delta mt} e^{-\frac{\Gamma}{2}t} - 1}{2} = \frac{1}{4} |\eta|^2 \left(1 + e^{-\frac{\Gamma}{2}t} (1 - 2 \cos \Delta mt) \right)$$

$$P_{\bar{K}^0}(K^0, t) \approx \frac{1}{4 |\eta|^2} \left(1 + e^{-\frac{\Gamma}{2}t} (1 - 2 \cos \Delta mt) \right)$$

$$P_{\bar{K}^0}(\bar{K}^0, t) \approx \frac{1}{4} \left(1 + e^{-\frac{\Gamma}{2}t} (1 + 2 \cos \Delta mt) \right)$$

CP Violation and SM - VIII

Transition probabilities

$$K^0 \rightarrow K^0 / \bar{K}^0 \rightarrow \bar{K}^0 :$$

Identical (CPT)

$$K^0 \rightarrow \bar{K}^0 / \bar{K}^0 \rightarrow K^0 :$$

Identical if $|\eta| = 1 \rightarrow$ No \mathcal{CP} in mixing: Full line

Different if $|\eta| \neq 1$: Dashed + Point lines

As shown prediction for $1 - |\eta| = 10 \times \text{Exp. value}$

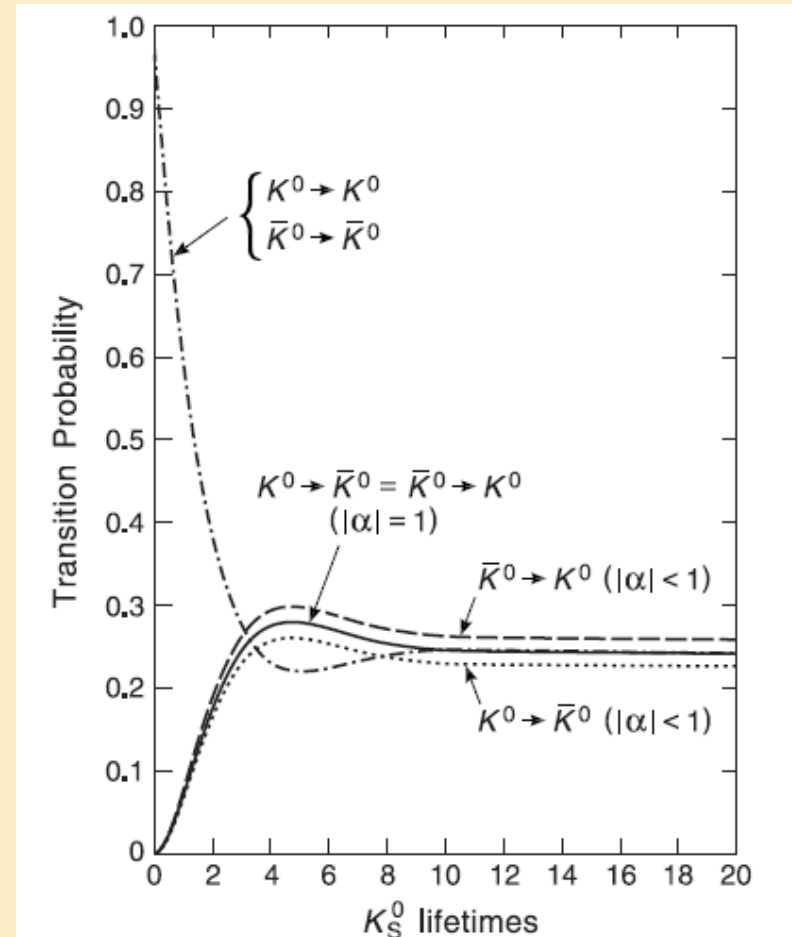

CP Violation and SM - IX

Rationale:

\mathcal{CP} observed in neutral kaon decays

Ascribed to mixing, decay, or both

Accounted for by a *single* complex phase in *CKM*

→ Expect \mathcal{CP} to occur in other neutral, flavored meson decays

→ Heavy quarks involved

Looking again at unitarity triangles:

$$\begin{aligned} (1) \quad V_{ud}V_{us}^* + V_{cd}V_{cs}^* + V_{td}V_{ts}^* &= 0; & (2) \quad V_{ud}V_{ub}^* + V_{cd}V_{cb}^* + V_{td}V_{tb}^* &= 0; \\ (3) \quad V_{us}V_{ub}^* + V_{cs}V_{cb}^* + V_{ts}V_{tb}^* &= 0; & (4) \quad V_{ud}^*V_{cd} + V_{us}^*V_{cs} + V_{ub}^*V_{cb} &= 0; \\ (5) \quad V_{ud}^*V_{td} + V_{us}^*V_{ts} + V_{ub}^*V_{tb} &= 0; & (6) \quad V_{cd}^*V_{td} + V_{cs}^*V_{ts} + V_{cb}^*V_{tb} &= 0 \end{aligned}$$

Not all equally useful: *Shape, Easy to measure*

CP Violation and SM - X

$$V_{ud}V_{ub}^* + V_{cd}V_{cb}^* + V_{td}V_{tb}^* = 0$$

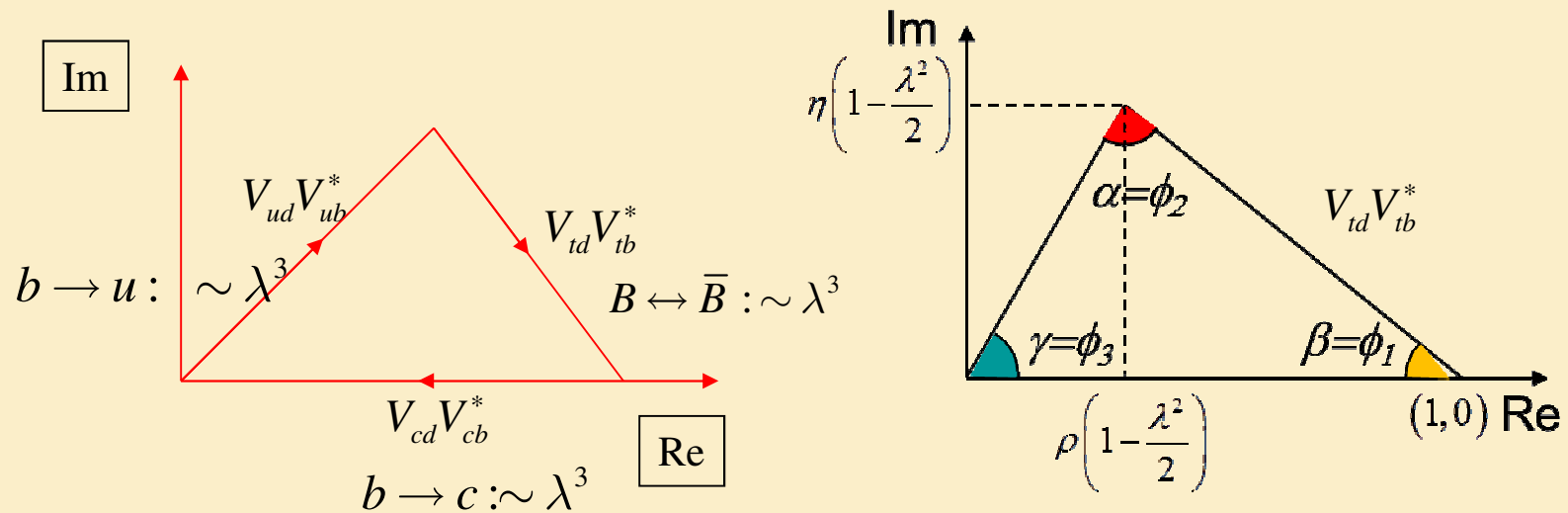

The unitarity triangle: Somewhat 'equilateral' \rightarrow Large angles

CP Violation and SM - XI

$$V_{ud}^* V_{td} + V_{us}^* V_{ts} + V_{ub}^* V_{tb} = \delta_{tu} = 0 \quad \hat{=} \quad tu \text{ triangle}$$

Another \approx equilateral one

Each side $\propto \lambda^3$

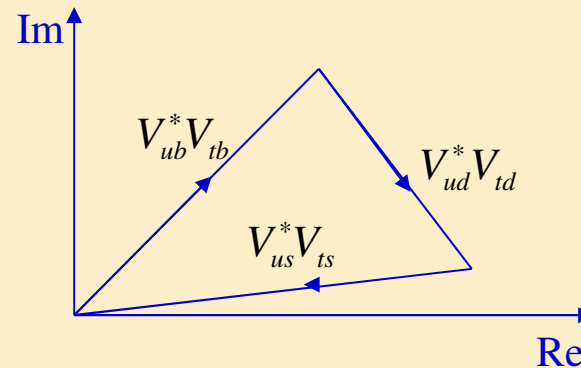

CP Violation and SM - XII

Two 'squashed' triangles...

2 sides $\propto \lambda^2$

1 side $\propto \lambda^4$

$$V_{us}^* V_{ub} + V_{cs}^* V_{cb} + V_{ts}^* V_{tb} = \delta_{bs} = 0 \quad \hat{=} \quad bs \text{ triangle}$$

$$V_{td}^* V_{cd} + V_{ts}^* V_{cs} + V_{tb}^* V_{cb} = \delta_{tc} = 0 \quad \hat{=} \quad tc \text{ triangle}$$

Difficult to use to test \mathcal{CP}

$\mathcal{CP} \propto$ Height with base normalized to 1

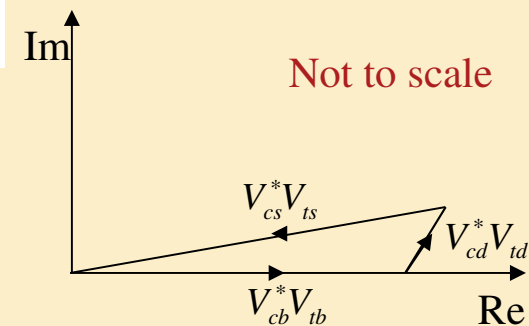
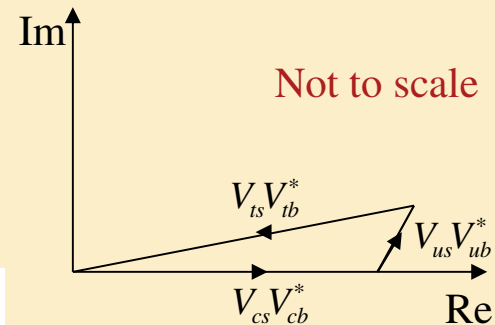

CP Violation and SM - XIII

...and two even more squashed

2 sides $\propto \lambda$

1 side $\propto \lambda^5$

$$V_{ud}^* V_{us} + V_{cd}^* V_{cs} + V_{td}^* V_{ts} = \delta_{sd} = 0 \quad \hat{=} \quad sd \text{ triangle}$$

$$V_{ud}^* V_{cd} + V_{us}^* V_{cs} + V_{ub}^* V_{cb} = \delta_{cu} = 0 \quad \hat{=} \quad cu \text{ triangle}$$

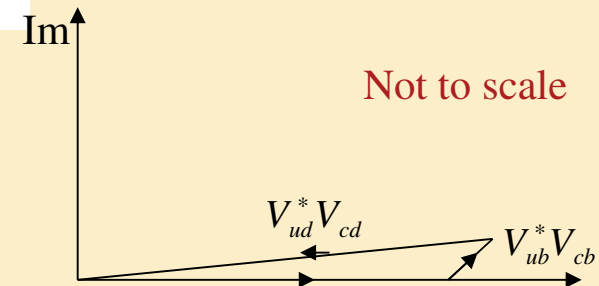
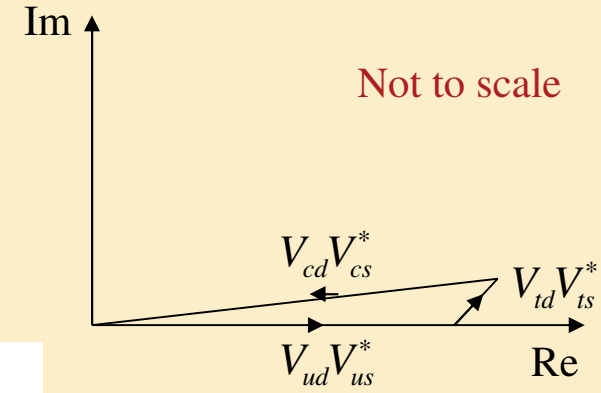

CP Violation and SM - XIV

Neutral, flavored mesons: Lightest states

$$K^0 : d\bar{s}$$

$$\bar{K}^0 : \bar{d}s$$

$$D^0 : c\bar{u}$$

$$\bar{D}^0 : \bar{c}u$$

$$B^0 : \bar{b}d$$

$$\bar{B}^0 : b\bar{d}$$

$$B_s^0 : \bar{b}s$$

$$\bar{B}_s^0 : b\bar{s}$$

	$\langle\tau\rangle$	Δm	$x=\Delta m/\Gamma$	$y=\Delta\Gamma/2\Gamma$
K^0	$2.6 \cdot 10^{-8} \text{ s}$	5.29 ns^{-1}	$\Delta m/\Gamma_S=0.49$	~ 1
D^0	$0.41 \cdot 10^{-12} \text{ s}$	0.001 fs^{-1}	~ 0	0.01
B^0	$1.53 \cdot 10^{-12} \text{ s}$	0.507 ps_1^{-1}	0.78	~ 0
B_s^0	$1.47 \cdot 10^{-12} \text{ s}$	17.8 ps^{-1}	12.1	~ 0.05

CP Violation and SM - XV

Lineshapes of mass eigenstates of neutral, flavored meson systems

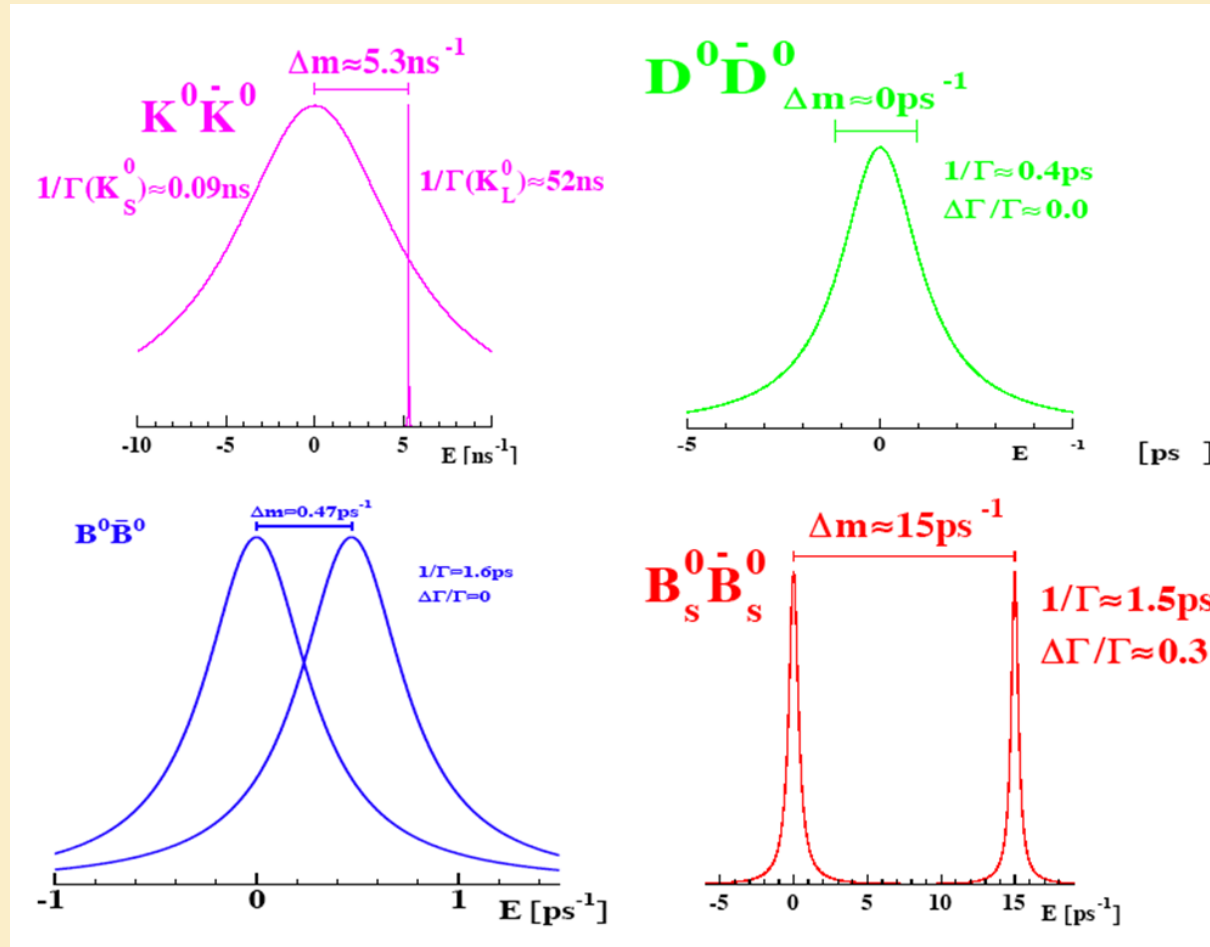

CP Violation and SM - XVI

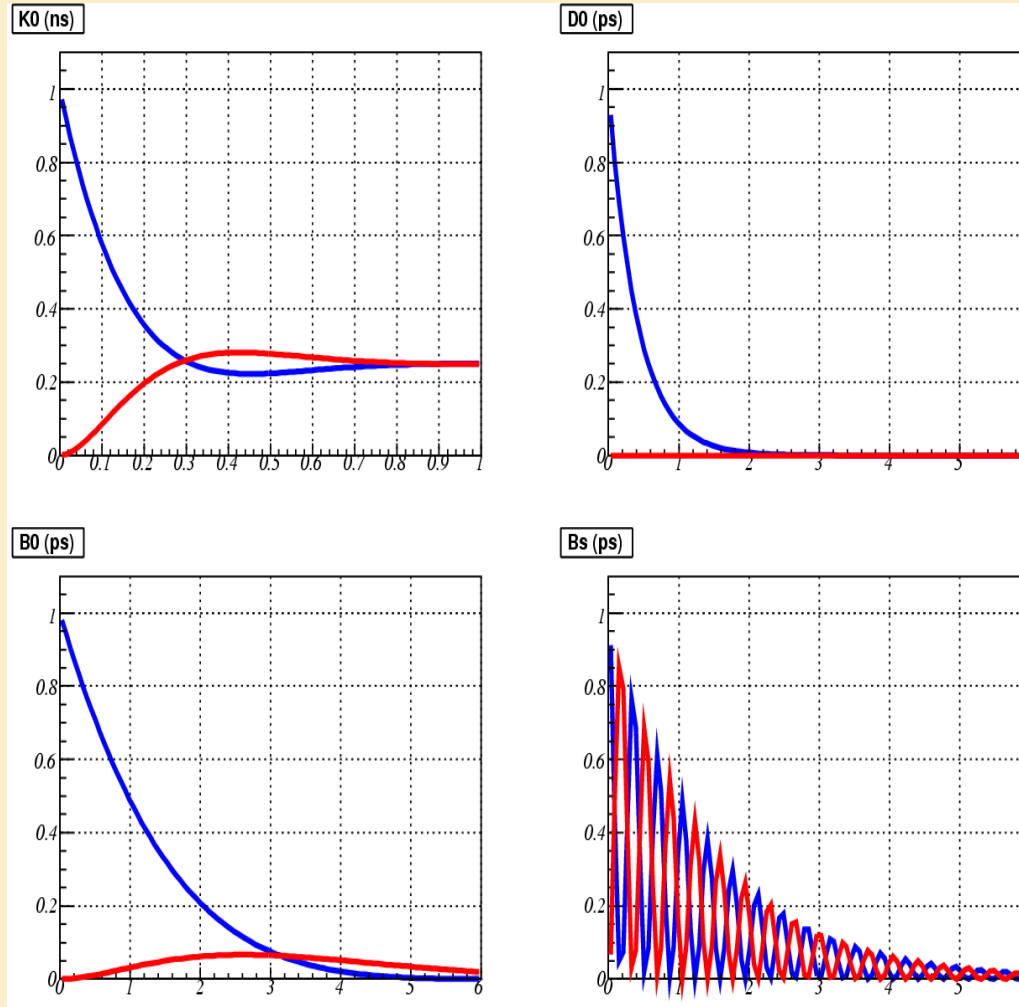

CP Violation and SM - XVII

Extend box diagrams to other neutral systems: $D^0 - \bar{D}^0$

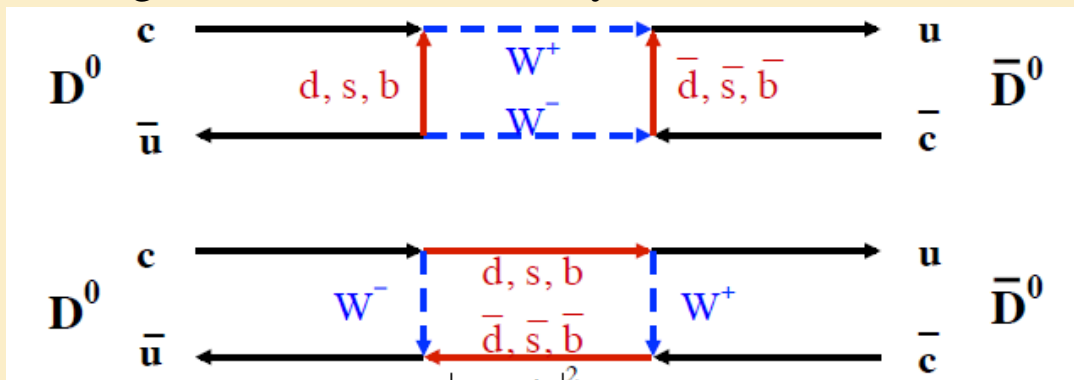

b loop: Strong CKM suppression

$$M \propto |V_{ub}V_{cb}^*|^2 \ll 1$$

Indeed, go to Wolfenstein parametrization:

$$|V_{ub}V_{cb}^*|^2 \sim |\lambda^3\lambda^2|^2 \sim 10^{-7}$$

s, d loops: Strong GIM suppression

$$M \propto (m_s^2 - m_d^2) \text{ small!}$$

→ Expect very small mixing

CP Violation and SM - XVIII

Long distance effects (← Meson exchange, rather than quarks) important

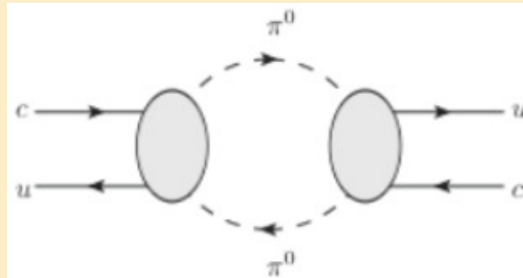

Lifetime, width, mass: Very different from K^0 , difficult to compute

$$m_1 \simeq m_2$$

$$\tau_1 \simeq \tau_2 = (4.15 \pm 0.04) 10^{-13} \text{ s}$$

$$\Gamma_2 \simeq \Gamma_1 = (1.59 \pm 0.01) 10^{-12} \text{ GeV}$$

$$\Gamma = \frac{\Gamma_1 + \Gamma_2}{2} \simeq \Gamma_2 \simeq \Gamma_1$$

$$\left. \begin{aligned} x &\equiv \frac{\Delta m}{\Gamma} = \frac{m_2 - m_1}{\Gamma} \\ y &\equiv \frac{\Delta \Gamma}{2\Gamma} = \frac{\Gamma_2 - \Gamma_1}{2\Gamma} \end{aligned} \right\} \text{Estimate } x, y \sim 10^{-4} - 10^{-3}$$

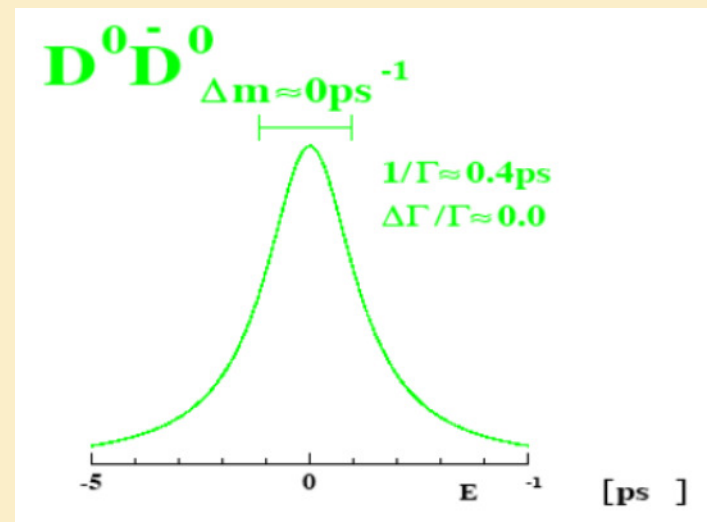

CP Violation and SM - XIX

~ Same mass: Oscillation frequency small

~ Same (small) lifetime : D_H, D_L cannot be physically separated (Compare to K_S / K_L ..)

→ Only chance to observe mixing by time integrated measurement

Tag D flavor at both production and decay

Production: Take strong decays

$$D^{*+} \rightarrow D^0 \pi^+, \bar{D}^{*-} \rightarrow \bar{D}^0 \pi^-$$

Decay: Take two modes

$D^0 \rightarrow K^+ \mu^- \bar{\nu}_\mu$ forbidden, only accessed by mixing $D^0 \rightarrow \bar{D}^0$

$D^0 \rightarrow K^- \mu^+ \nu_\mu$ allowed

$$\rightarrow R = \frac{N(K^+ \mu^- \bar{\nu}_\mu)}{N(K^- \mu^+ \nu_\mu)} \simeq \frac{x^2 + y^2}{2}$$

Measurement difficult, large samples required

Mixing & \mathcal{CP} observed since 2007 by BaBar, Belle, LHCb

CP Violation and SM - XX

Most promising sector for validation of *CKM* : $B^0 - \bar{B}^0$

'Large' \mathcal{CP} expected

Similar to $K^0 - \bar{K}^0$, but:

$$\Delta M_B = 0.489 \pm 0.008 \text{ ps}^{-1}$$

$$\rightarrow \Delta M_B \sim 0.489 \cdot 10^{12} \text{ s}^{-1}$$

$$\hbar \approx 6.582 \cdot 10^{-16} \text{ eV s} \rightarrow \Delta M_B \sim 3.22 \cdot 10^{-4} \text{ eV} \sim 100 \Delta M_K$$

$$\tau_{B_1} \approx \tau_{B_2} = 1.56 \pm 0.06 \text{ ps}$$

$$\rightarrow \frac{\Delta M_B}{\Gamma_B} \sim 1$$

Compare to *K*:

$$\Delta M_K = 5.29 \text{ ns}^{-1} \sim 5.29 \cdot 10^9 \text{ s}^{-1} \cdot 6.582 \cdot 10^{-16} \text{ eV s} \sim 3.4 \cdot 10^{-6} \text{ eV}$$

$$\rightarrow \frac{\Delta M_K}{\Gamma_{K_S}} \sim 1$$

$$\tau_L \sim 600 \tau_S \sim 600 \cdot 89 \text{ ps}$$

B_H, B_L states cannot be physically separated

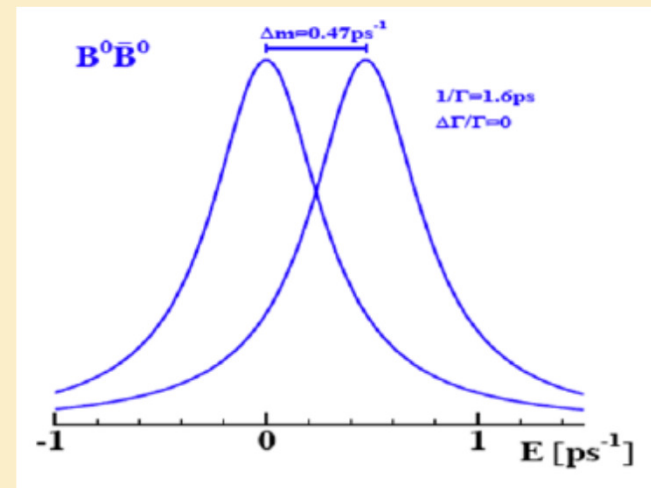

B Mixing: CP - I

Box diagrams, t dominated for B^0

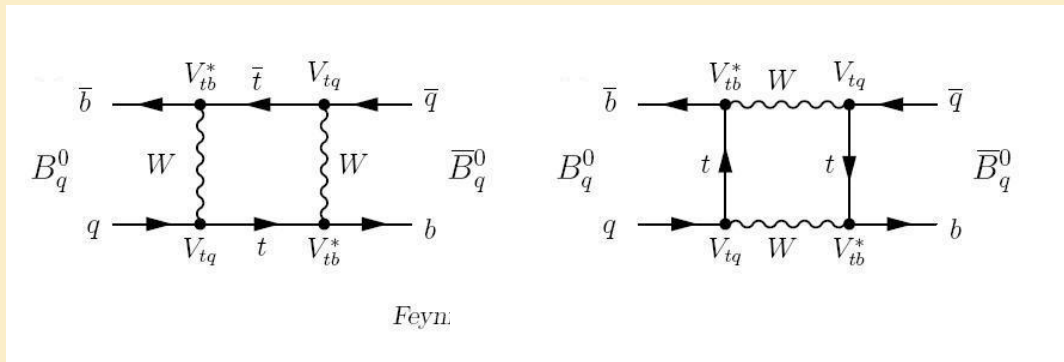

$$\begin{pmatrix} 1 - \frac{\lambda^2}{2} & \lambda & A\lambda^3(\rho - i\eta) \\ -\lambda & 1 - \frac{\lambda^2}{2} & A\lambda^2 \\ A\lambda^3(1 - \rho - i\eta) & -A\lambda^2 & 1 \end{pmatrix}$$

Mixing parameter:

$$\eta = \frac{(V_{tb}^* V_{td})}{(V_{tb} V_{td}^*)} \approx \frac{V_{td}}{V_{td}^*} = e^{-2i\varphi_{td}}$$

From UT:

$$\varphi_{td} = \beta$$

$$\rightarrow \eta = e^{-2i\beta}$$

$$\rightarrow |\eta| \cong 1$$

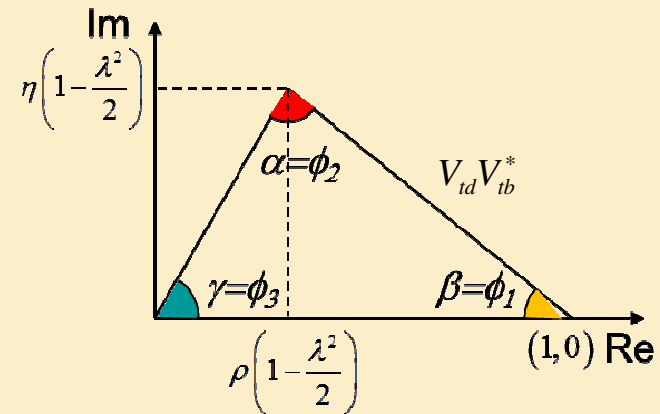

B Mixing: CP - II

Mass eigenstates:

$$\left\{ \begin{array}{l} |B_H\rangle = \frac{1}{\sqrt{1+|\eta|^2}} (|B^0\rangle + \eta |\bar{B}^0\rangle) \\ |B_L\rangle = \frac{1}{\sqrt{1+|\eta|^2}} (|B^0\rangle - \eta |\bar{B}^0\rangle) \end{array} \right. , \quad \left\{ \begin{array}{l} |B^0\rangle = \frac{1}{2} \sqrt{1+|\eta|^2} (|B_H\rangle + |B_L\rangle) \\ |\bar{B}^0\rangle = \frac{1}{2\eta} \sqrt{1+|\eta|^2} (|B_H\rangle - |B_L\rangle) \end{array} \right.$$

$$\rightarrow \eta = \frac{1 - \varepsilon_B}{1 + \varepsilon_B}, \quad \varepsilon_B \text{ analog to } \varepsilon \text{ used for kaons}$$

Time evolution of mass eigenstates:

$$\rightarrow \left\{ \begin{array}{l} |B_H(t)\rangle = |B_H\rangle e^{-i(m_H - i\frac{\Gamma_H}{2})t} \\ |B_L(t)\rangle = |B_L\rangle e^{-i(m_L - i\frac{\Gamma_L}{2})t} \end{array} \right. , \quad \Gamma_H \simeq \Gamma_L = \Gamma, \quad \Delta m \ll M$$

B Mixing: CP - III

Time evolution of flavor eigenstates:

$$\begin{cases} |B^0(t)\rangle = |B^0\rangle f_+(t) + \eta |\overline{B}^0\rangle f_-(t) \\ |\overline{B}^0(t)\rangle = |B^0\rangle \frac{1}{\eta} f_-(t) + |\overline{B}^0\rangle f_+(t) \end{cases}$$

$$f_+(t) = \frac{e^{-i\left(M + \frac{\Delta m}{2} - i\frac{\Gamma_H}{2}\right)t} + e^{-i\left(M - \frac{\Delta m}{2} - i\frac{\Gamma_L}{2}\right)t}}{2}, \quad f_-(t) = \frac{e^{-i\left(M + \frac{\Delta m}{2} - i\frac{\Gamma_H}{2}\right)t} - e^{-i\left(M - \frac{\Delta m}{2} - i\frac{\Gamma_L}{2}\right)t}}{2}$$

$$f_{\pm}(t) \approx \frac{1}{2} e^{-\frac{1}{2}\Gamma t} e^{-iMt} \left[e^{-i\frac{\Delta m}{2}t} \pm e^{+i\frac{\Delta m}{2}t} \right], \quad M = \frac{m_H + m_L}{2}, \quad \Delta m > 0, \quad \Gamma_H \simeq \Gamma_L = \Gamma$$

$$\rightarrow \begin{cases} f_+(t) \approx \frac{1}{2} e^{-\frac{1}{2}\Gamma t} e^{-iMt} \cos\left(\frac{\Delta m}{2}t\right) \\ f_-(t) \approx -i\frac{1}{2} e^{-\frac{1}{2}\Gamma t} e^{-iMt} \sin\left(\frac{\Delta m}{2}t\right) \end{cases}$$

$$\rightarrow \begin{cases} |B^0(t)\rangle = e^{-iMt} e^{-\frac{1}{2}\Gamma t} \left[\cos\left(\frac{\Delta m}{2}t\right) |B_0\rangle - i\eta \sin\left(\frac{\Delta m}{2}t\right) |\overline{B}_0\rangle \right] \\ |\overline{B}^0(t)\rangle = e^{-iMt} e^{-\frac{1}{2}\Gamma t} \left[-\frac{i}{\eta} \sin\left(\frac{\Delta m}{2}t\right) |B_0\rangle + \cos\left(\frac{\Delta m}{2}t\right) |\overline{B}_0\rangle \right] \end{cases}$$

B Mixing: CP - IV

→ Expect:

$$\Gamma(B^0(t=0) \rightarrow B^0) = e^{-\Gamma t} \cos^2\left(\frac{\Delta m}{2} t\right)$$

$$\Gamma(B^0(t=0) \rightarrow \bar{B}^0) = |\eta|^2 e^{-\Gamma t} \sin^2\left(\frac{\Delta m}{2} t\right)$$

$$\Gamma(\bar{B}^0(t=0) \rightarrow \bar{B}^0) = e^{-\Gamma t} \cos^2\left(\frac{\Delta m}{2} t\right)$$

$$\Gamma(\bar{B}^0(t=0) \rightarrow B^0) = \left|\frac{1}{\eta}\right|^2 e^{-\Gamma t} \sin^2\left(\frac{\Delta m}{2} t\right)$$

Similar for B_s^0 :

Important difference $\Delta m \gg \Gamma$

→ Many oscillations in a lifetime

B Mixing: CP - V

Unlike K^0 / \bar{K}^0 :

$|\eta| \simeq 1 \rightarrow \sim$ No \mathcal{CP} effect observable by looking at flavor oscillations

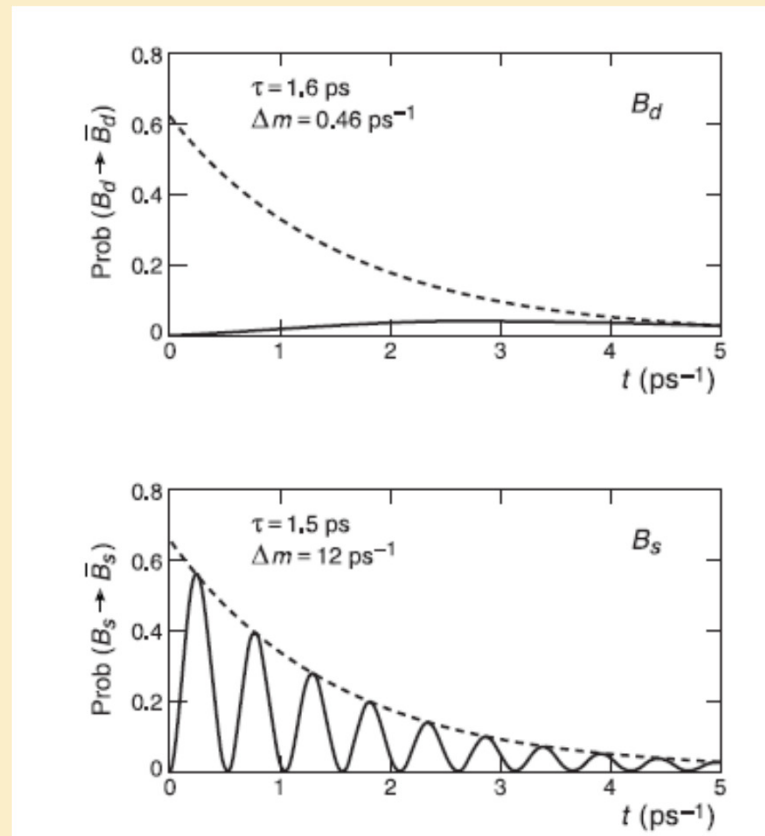

B Mixing: CP - VI

By restricting to decays to CP eigenstates: OK!

Main disadvantage: Statistics (Tiny BR)

Golden final state: $J/\psi K_S^0$ (or K_L^0 : Experimentally less attractive)

$$B^0, \bar{B}^0 \rightarrow J/\psi K_S^0$$

Angular momentum balance:

$$0 = 1 \oplus 0 \oplus L \rightarrow L = 1 \quad \text{Pure } P\text{-wave}$$

$$CP(J/\psi) = (-1)(-1) = +1$$

$$CP(K_S^0) = +1, \text{ neglect } \mathcal{CP} \text{ in } K^0$$

$$P_{orb} = (-1)^L = -1$$

$$\rightarrow CP(J/\psi K_S^0) = -1$$

$$\rightarrow CP(J/\psi K_L^0) = +1$$

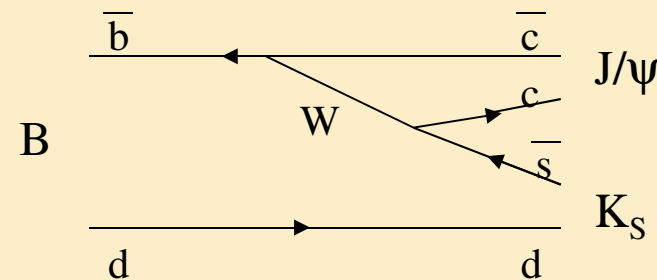

B Mixing: CP - VII

Another golden : $\pi\pi$

$$B^0, \bar{B}^0 \rightarrow \pi\pi$$

Angular momentum balance:

$L=0$ Pure S -wave

$$CP(\pi\pi) = +1$$

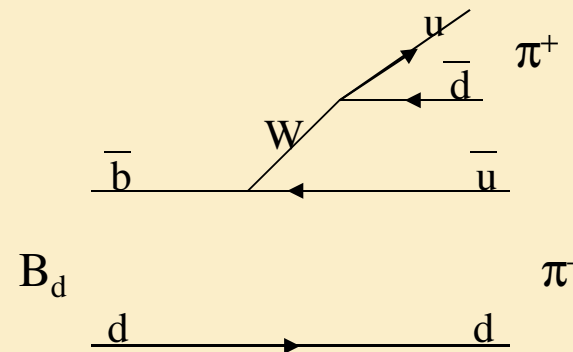

B Mixing: CP - VIII

Taking decays into (golden) CP eigenstates:

$$A(B^0 \rightarrow J/\psi K_S^0) = \langle J/\psi K_S^0 | H_{eff} | B^0(t) \rangle$$

$$\rightarrow A(B^0 \rightarrow J/\psi K_S^0) = f_+(t) \langle J/\psi K_S^0 | H_{eff} | B^0 \rangle + \eta f_-(t) \langle J/\psi K_S^0 | H_{eff} | \bar{B}^0 \rangle$$

$$\rightarrow A(B^0 \rightarrow J/\psi K_S^0) = \langle J/\psi K_S^0 | H_{eff} | B^0 \rangle \left[f_+(t) + \eta f_-(t) \frac{\langle J/\psi K_S^0 | H_{eff} | \bar{B}^0 \rangle}{\langle J/\psi K_S^0 | H_{eff} | B^0 \rangle} \right]$$

Considering B^0, \bar{B}^0 decay: Must occur in two steps

$$B^0 \rightarrow J/\psi K^0 \rightarrow J/\psi K_S^0 \quad \bar{B}^0 \rightarrow J/\psi \bar{K}^0 \rightarrow J/\psi K_S^0$$

because at the quark level:

$$\bar{b} \rightarrow \bar{c} \bar{c} s \quad b \rightarrow c \bar{c} s$$

$$A(B^0 \rightarrow J/\psi K^0) \propto V_{cb}^* V_{cs} \quad A(\bar{B}^0 \rightarrow J/\psi \bar{K}^0) \propto V_{cb} V_{cs}^*$$

$$\rightarrow \frac{\langle J/\psi K_S^0 | H_{eff} | \bar{B}^0 \rangle}{\langle J/\psi K_S^0 | H_{eff} | B^0 \rangle} = +1 \quad \text{CKM elements involved } \textit{real}$$

$$\frac{\langle \psi K_L | H | \bar{B}^0 \rangle}{\langle \psi K_L | H | B^0 \rangle} = -1.$$

B Mixing: CP - IX

$$\Gamma(B^0(t=0) \rightarrow J/\psi K_S) \propto |f_+(t) + \eta f_-(t)|^2$$

$$\rightarrow \Gamma(B^0(t=0) \rightarrow J/\psi K_S) \propto e^{-\Gamma t} \left| \cos\left(\frac{\Delta m}{2}t\right) - ie^{-2i\beta} \sin\left(\frac{\Delta m}{2}t\right) \right|^2$$

$$\rightarrow \Gamma(B^0(t=0) \rightarrow J/\psi K_S) \propto e^{-\Gamma t} (1 - \sin \Delta m t \sin 2\beta)$$

$$\rightarrow \Gamma(\bar{B}^0(t=0) \rightarrow J/\psi K_S) \propto e^{-\Gamma t} (1 + \sin \Delta m t \sin 2\beta)$$

Time dependent asymmetry:

$$A_{J/\psi K_S} = \frac{\Gamma(B^0(t=0) \rightarrow J/\psi K_S) - \Gamma(\bar{B}^0(t=0) \rightarrow J/\psi K_S)}{\Gamma(B^0(t=0) \rightarrow J/\psi K_S) + \Gamma(\bar{B}^0(t=0) \rightarrow J/\psi K_S)} = \sin \Delta m t \sin 2\beta$$

$$A_{J/\psi K_L} = -\sin \Delta m t \sin 2\beta$$

B Factories - I

Total e^+e^- annihilation cross section:

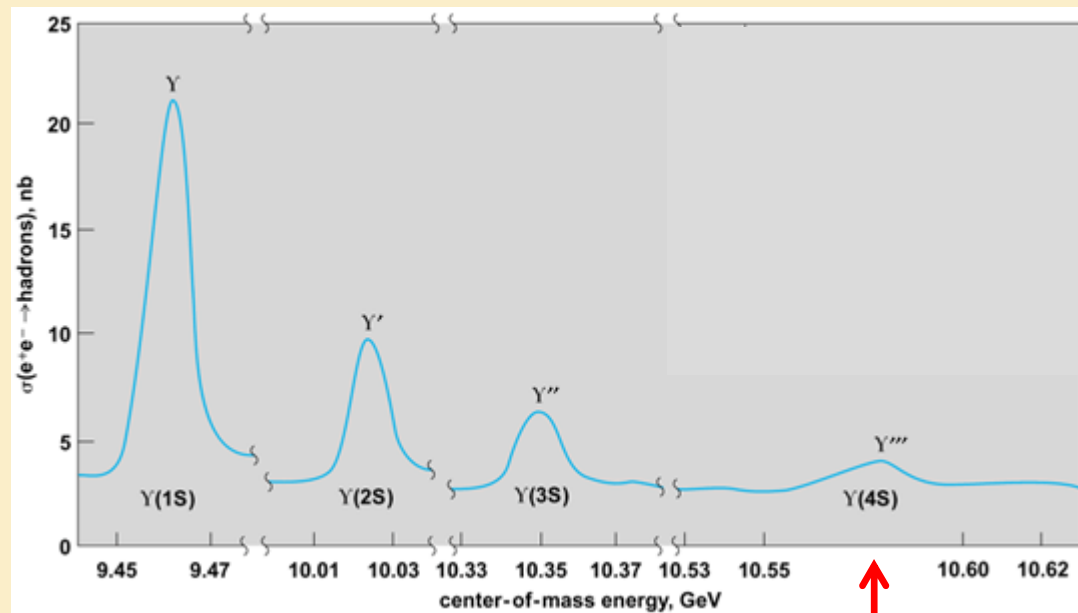

Main decay mode for $\Upsilon(4S)$:
 $\Upsilon(4S) \rightarrow B\bar{B}$, including $B^0\bar{B}^0$

B Factories - II

Basic idea to measure time dependent asymmetry:

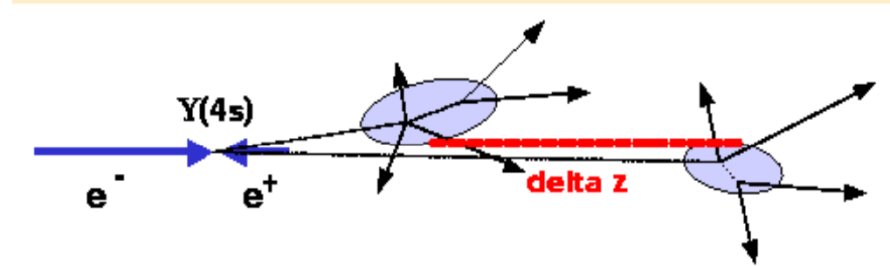
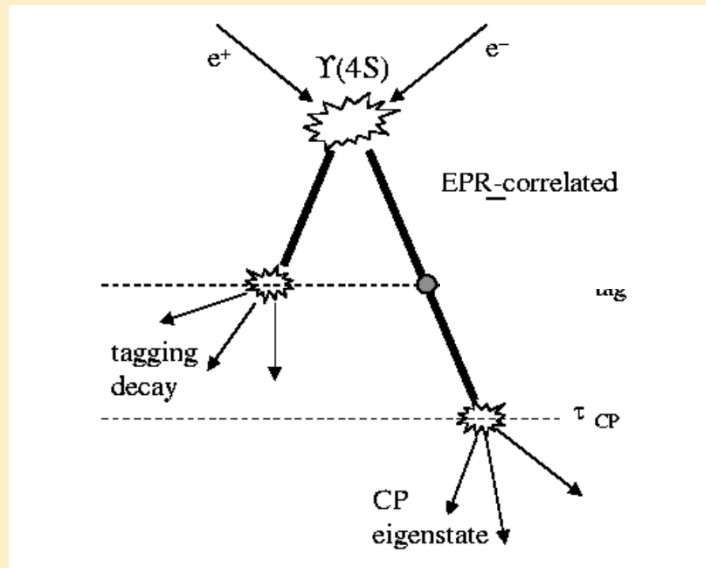

Measure time difference between 'tag' meson and 'CP' meson decays:

Use space distance between vertexes

Measurement difficult in CM, due to short lifetime ($d \sim 30 \mu m$)

→ Boost mesons in lab by making collider *asymmetric*

→ $\Upsilon(4S)$ moving in the lab system

B Factories - III

Example:

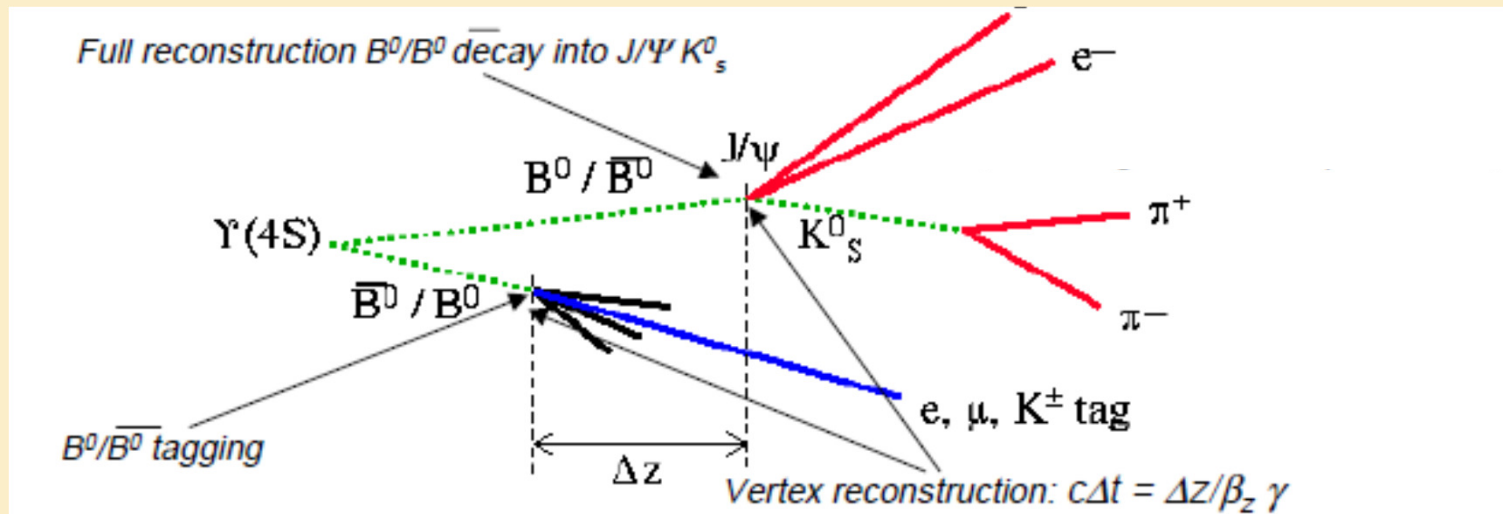

B Factories - IV

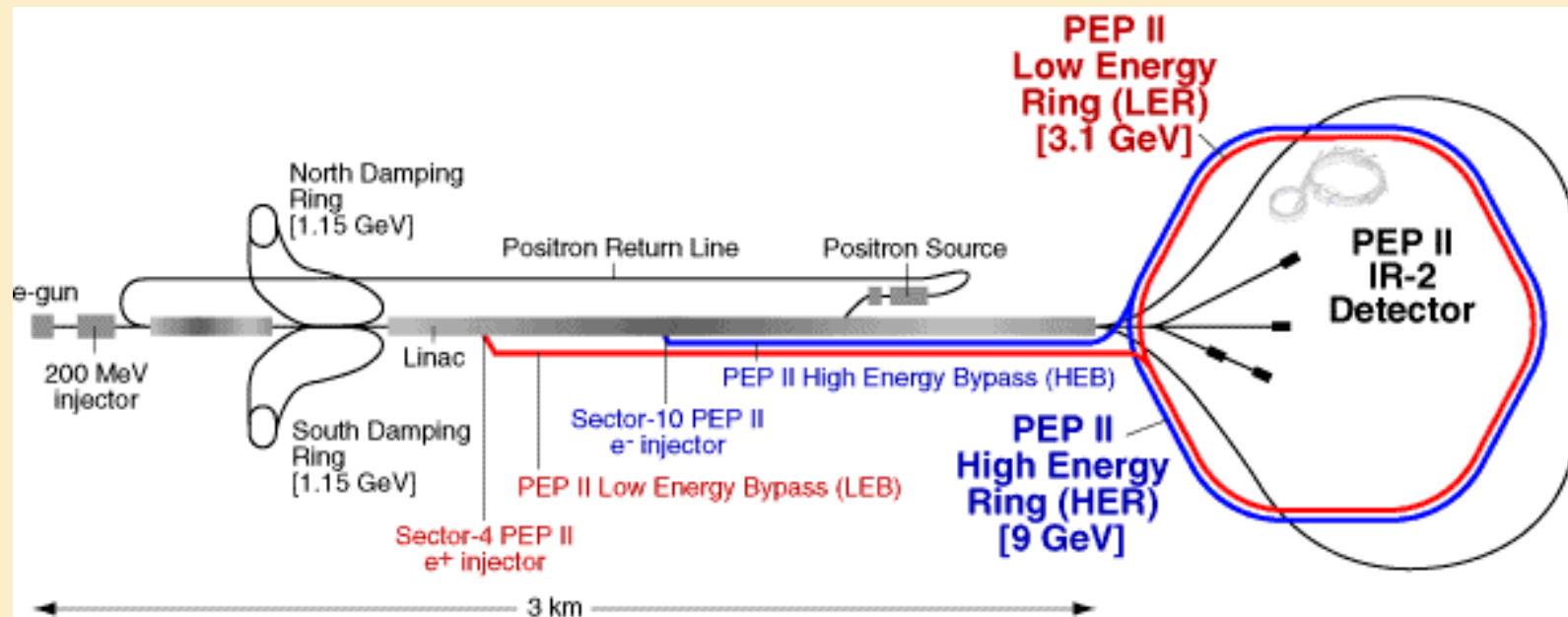

B Factories - V

BABAR

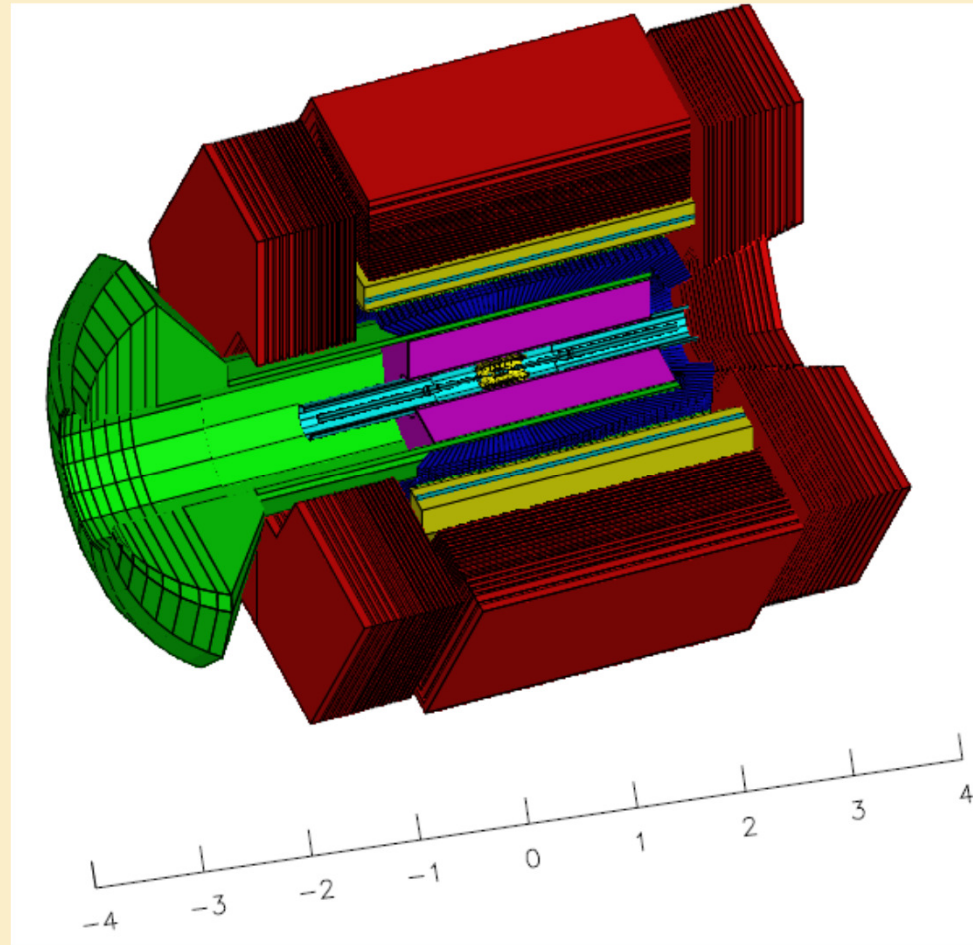

B Factories - VI



B Factories - VII

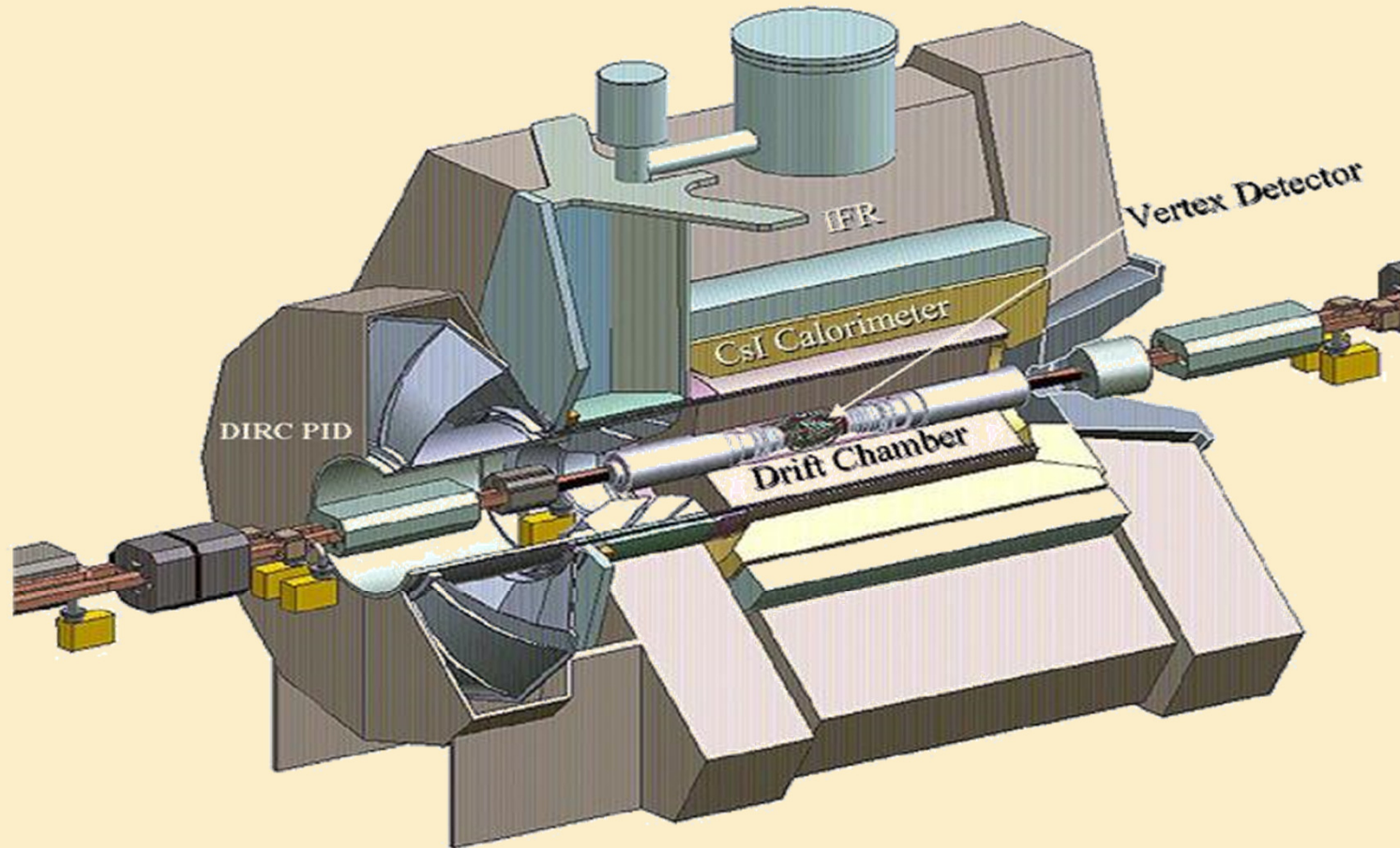

B Factories - VIII

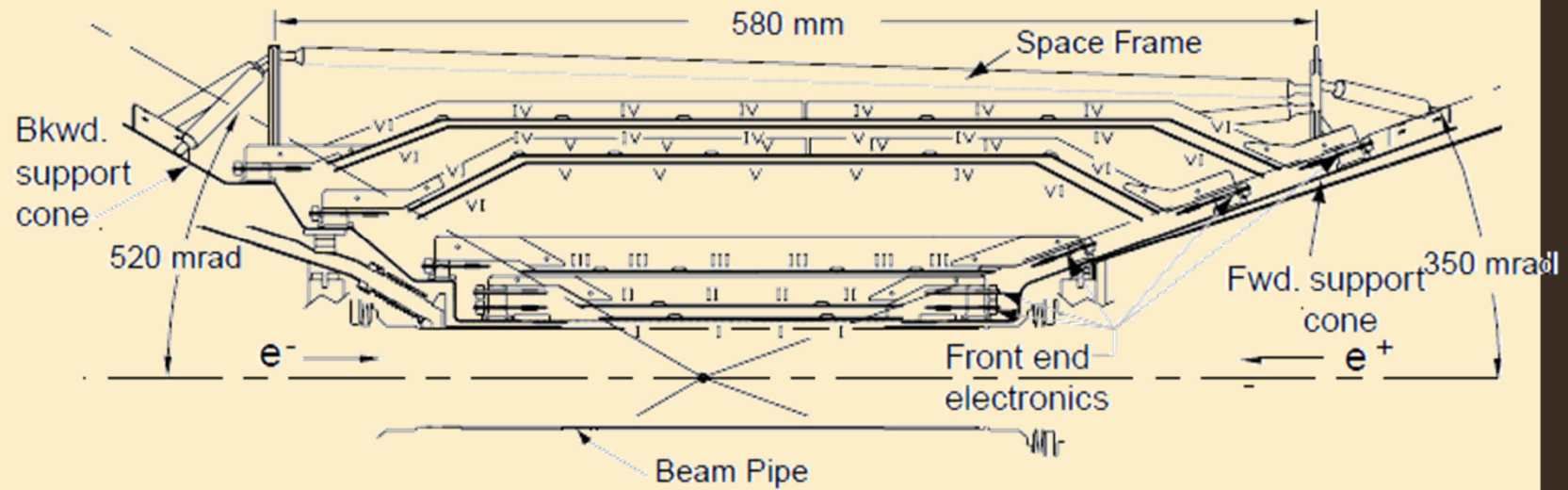

Vertex detector

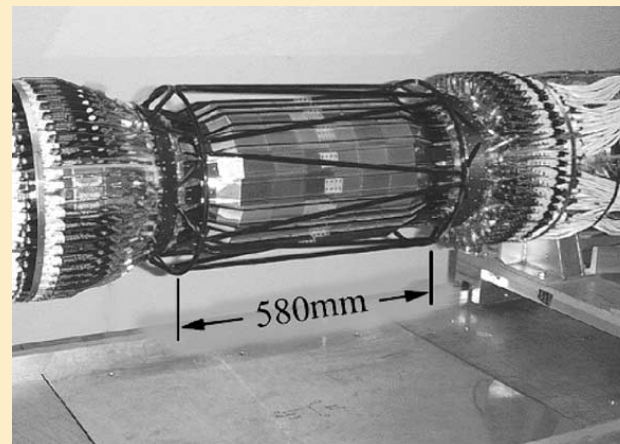

B Factories - IX

Drift chamber

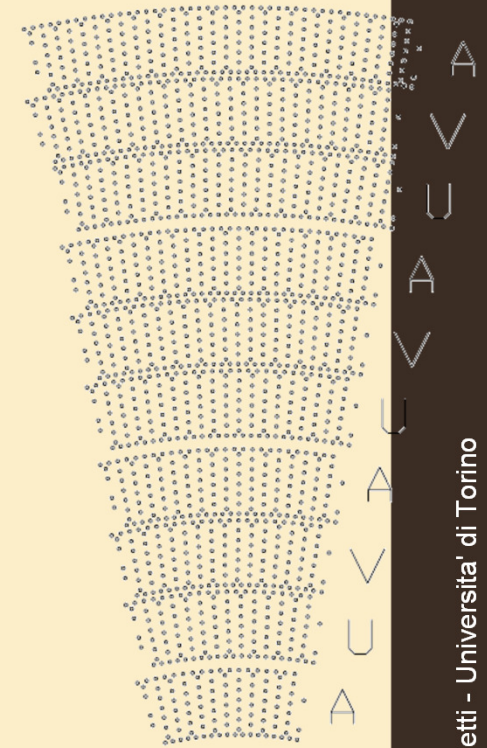
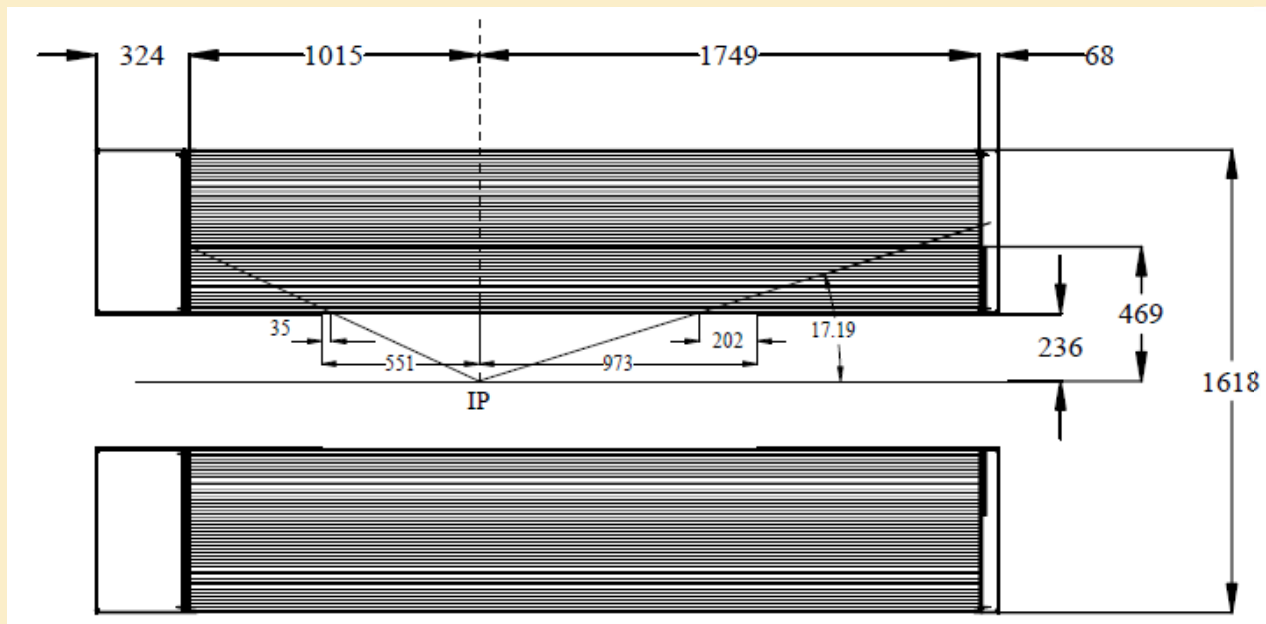

B Factories - X

DIRC : Particle Id

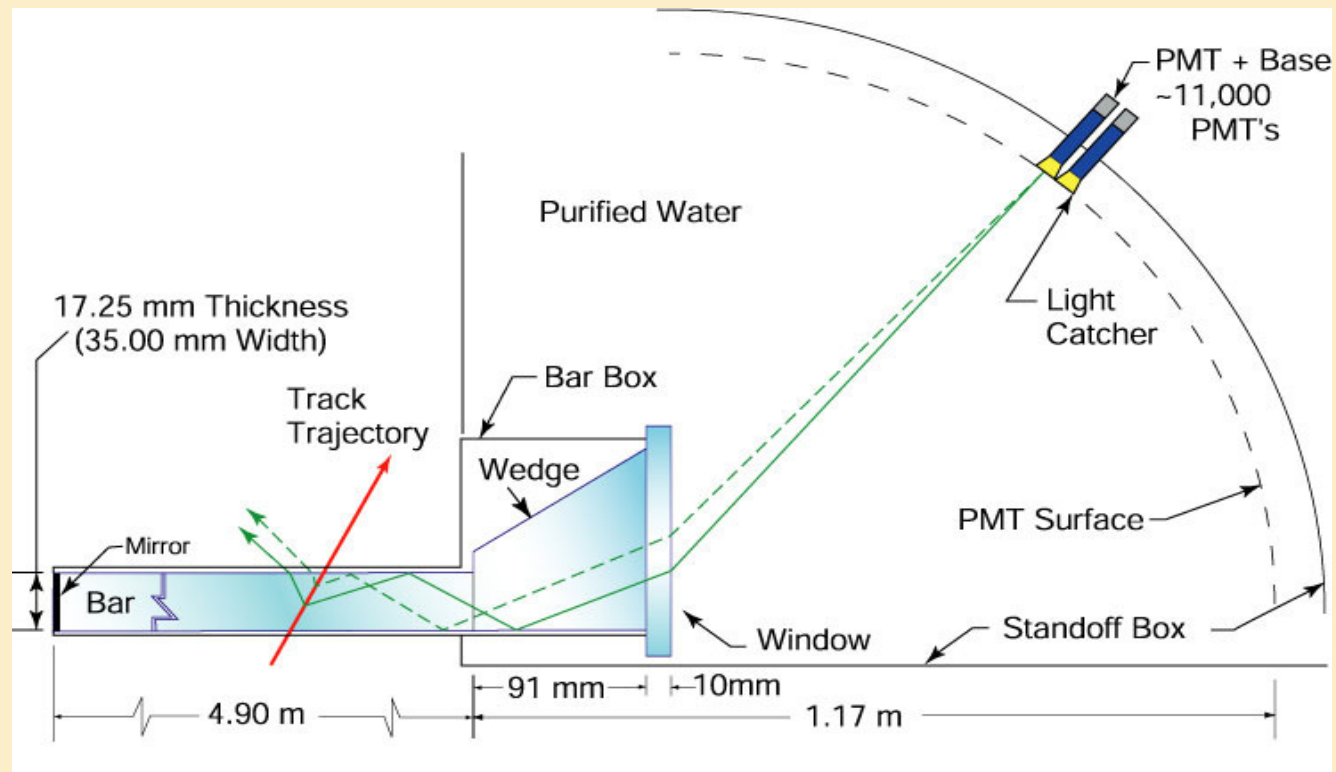

B Factories - XI

DIRC

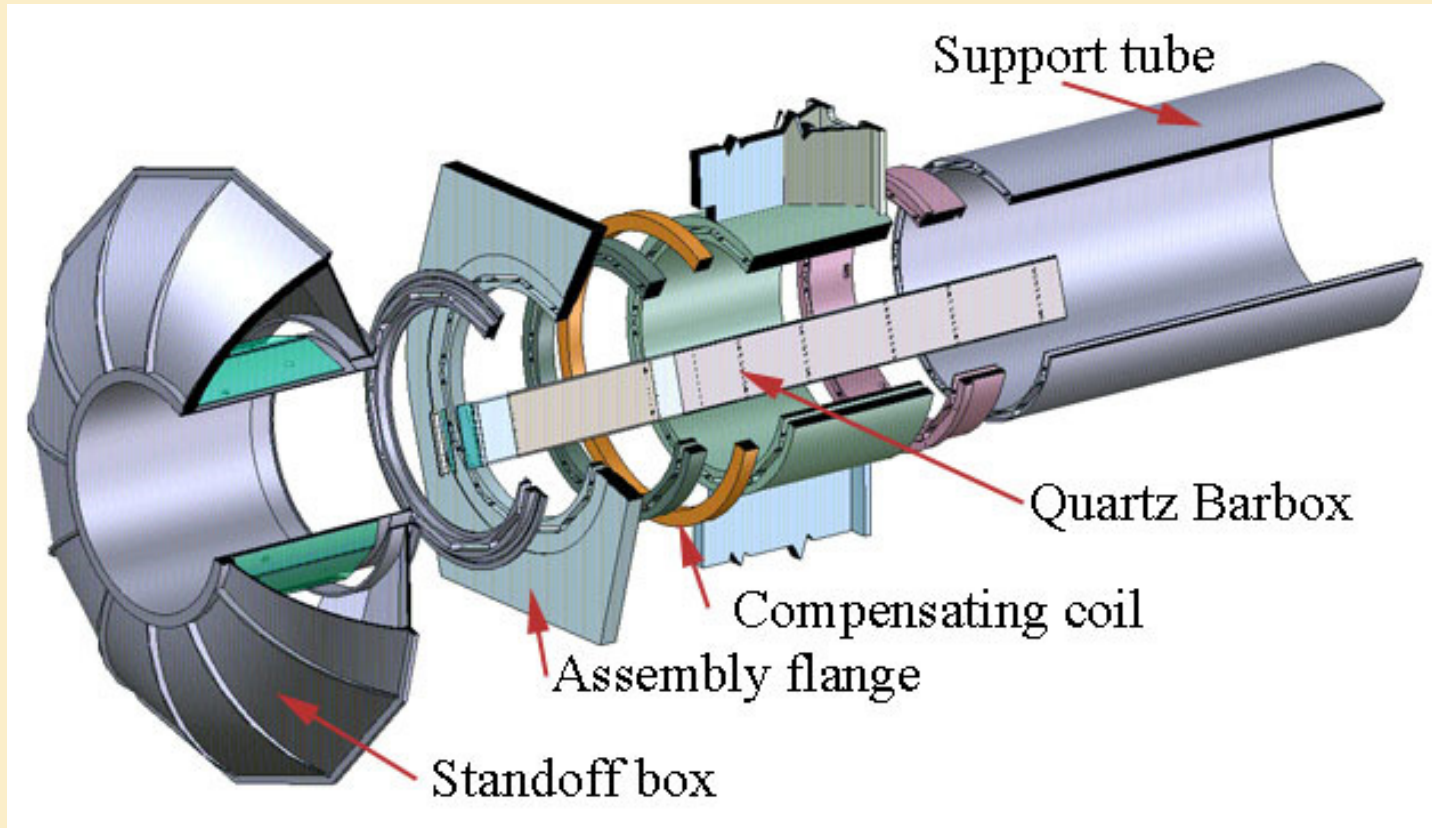

B Factories - XII

EM Calorimeter

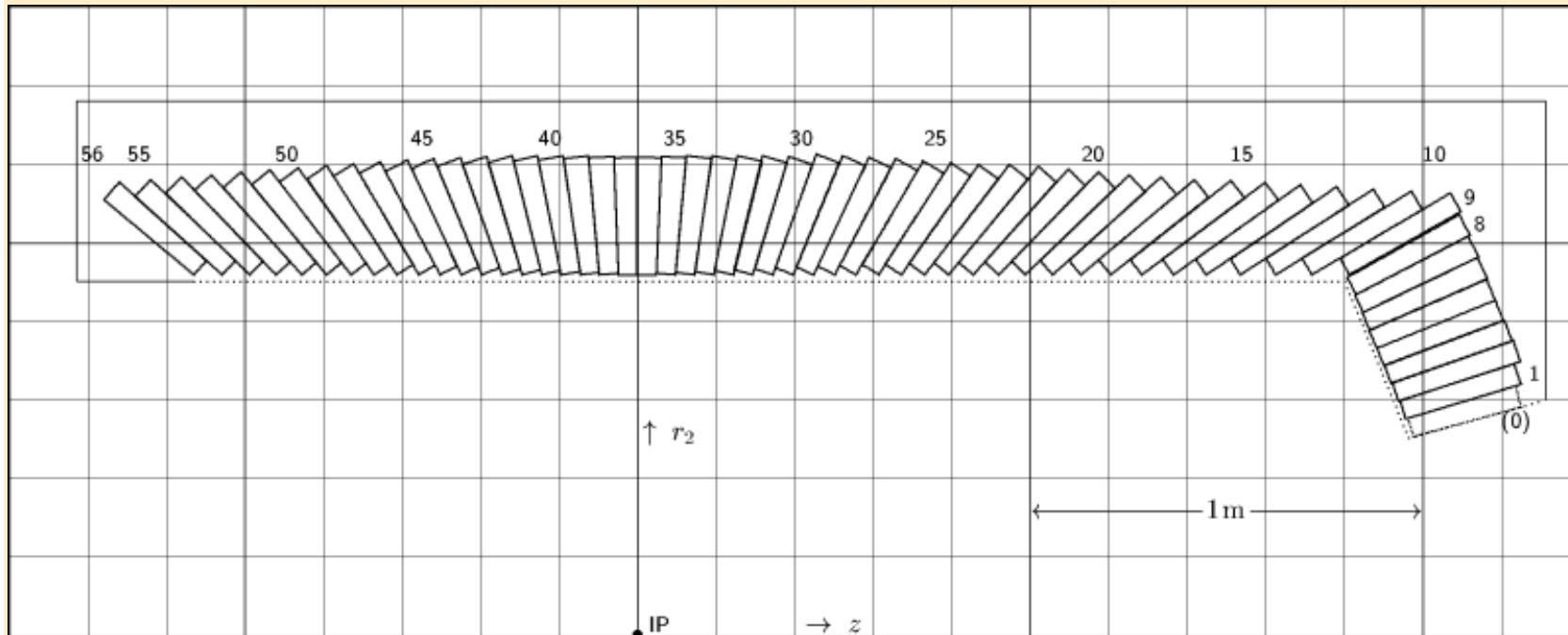

B Factories - XIII

Instrumented Flux Return: Muon detector & (coarse) hadron calorimeter

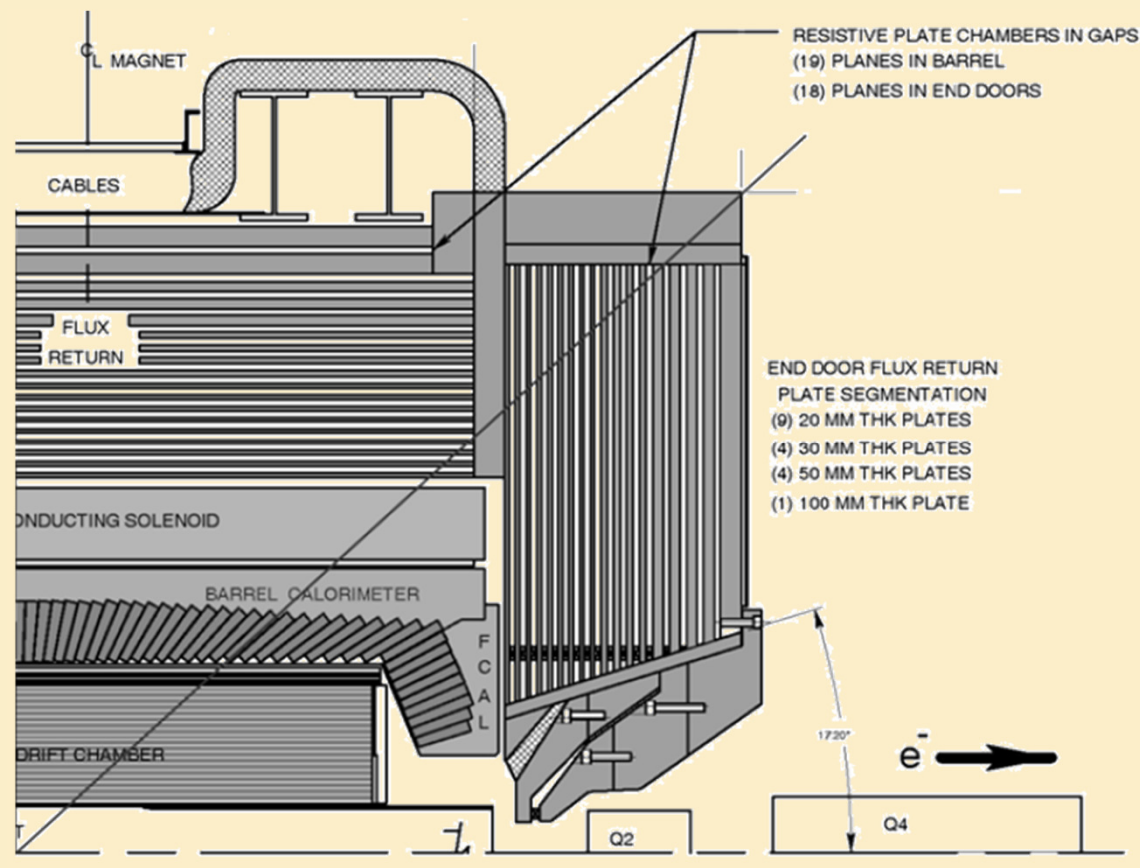

B Factories - XIV

Tagging: finding the flavor of the 2nd B-meson

Leptons : cleanest tag (correct=97%, efficiency=8.6%)



Kaons : 2nd cleanest tag (correct 85%-95%, efficiency=28%)

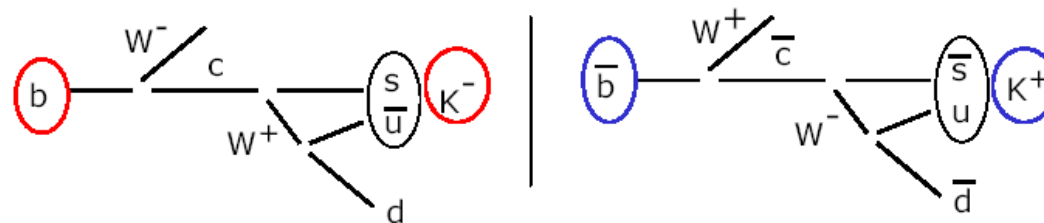

$w = \text{mistag probability} = 1 - \text{correct}$ “dilution”: $D = 1 - 2w$

B Factories - XV

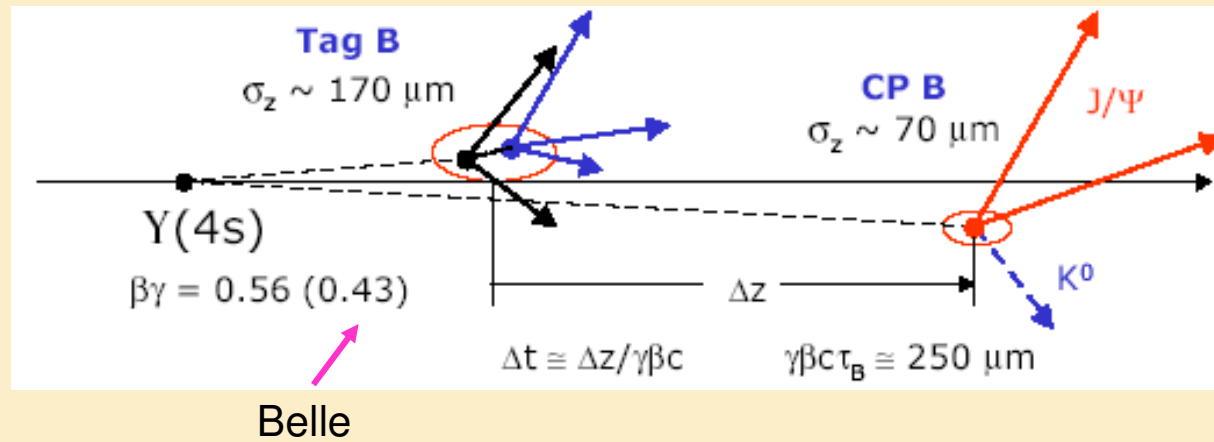

B Factories - XVI

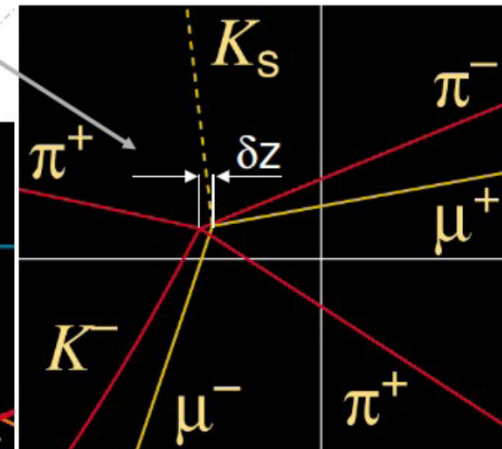
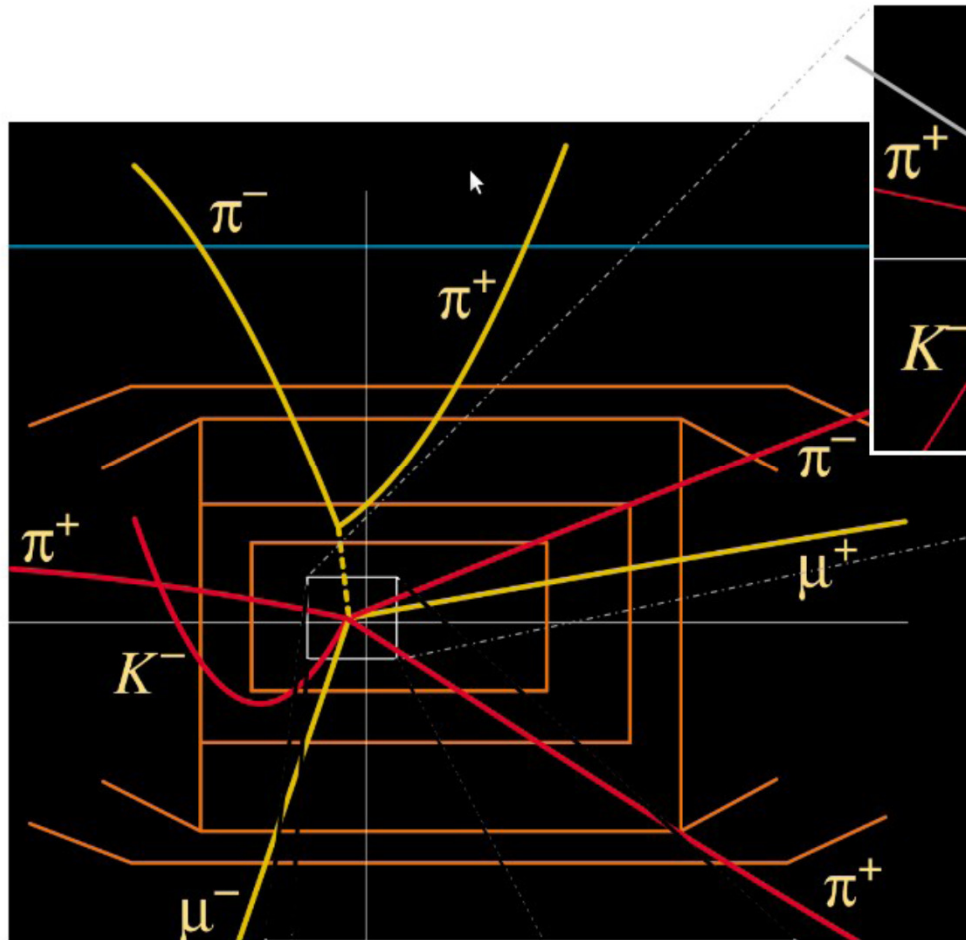

I: autostato CP
 $Y(4s) \rightarrow B^0 \rightarrow J/\psi K_s$
 ($\rightarrow \pi^+ \pi^-$)
 $\rightarrow B^0 \rightarrow K^+ X$
 II: etichettatura del sapore

B Factories - XVII

BABAR

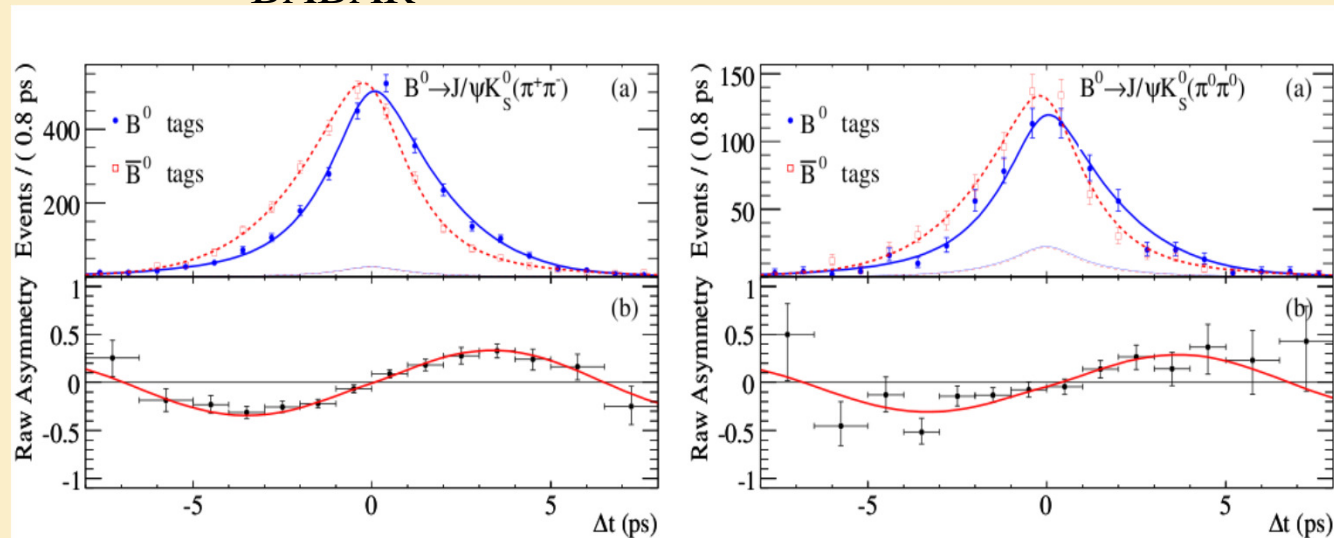

Sample	$-\eta_f S_f$	C_f
Full CP sample	0.687 ± 0.028	0.024 ± 0.020
$J/\psi K_S^0(\pi^+\pi^-)$	0.662 ± 0.039	0.017 ± 0.028
$J/\psi K_S^0(\pi^0\pi^0)$	0.625 ± 0.091	0.091 ± 0.063