

Convenzione, per tensioni e correnti:

a_x val. incrementale

a_x val. totale

A_x val. statico

Transcaratteristica a emittitore comune: i_C vs v_{BE}

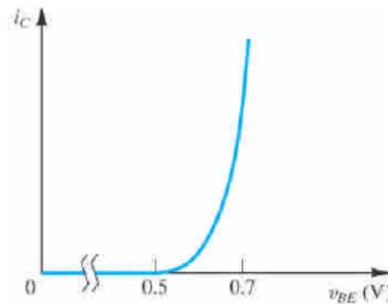

$I_C = I_S e^{V_{BE}/V_T}$ simile a diodo (ma I_C non e' la corrente della giunzione)

$v_{BE} = V_{BE} + v_{be}$ separazione di tensione statica e dinamica

$$\rightarrow i_C = I_S e^{v_{BE}/V_T} = I_S e^{(V_{BE} + v_{be})/V_T} = I_C e^{v_{be}/V_T}$$

Piccoli segnali:

$$v_{be} \ll V_T \rightarrow i_C \approx I_C \left(1 + \frac{v_{be}}{V_T} \right) = I_C + \frac{I_C}{V_T} v_{be} \rightarrow i_c \approx \frac{I_C}{V_T} v_{be}$$

$$\frac{I_C}{V_T} \equiv g_m \text{ transconduttanza, } \frac{V_T}{I_C} \equiv r_e \text{ res. equivalente di emittitore } \rightarrow r_e = \frac{1}{g_m}$$

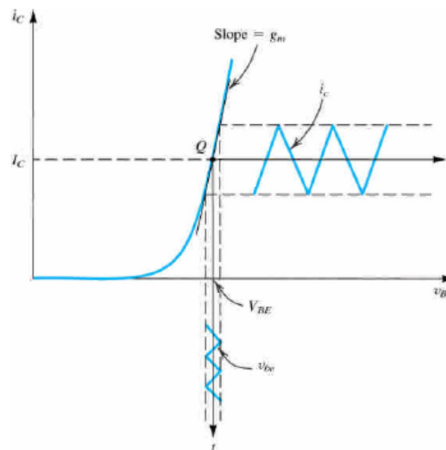

Non idealita' delle caratteristiche di uscita:

Corrente di collettore *non* indipendente dalla tensione CE

→ Il collettore *non* e' un generatore ideale di corrente

→ Equivalente a generatore ideale con in parallelo resistenza interna r_0

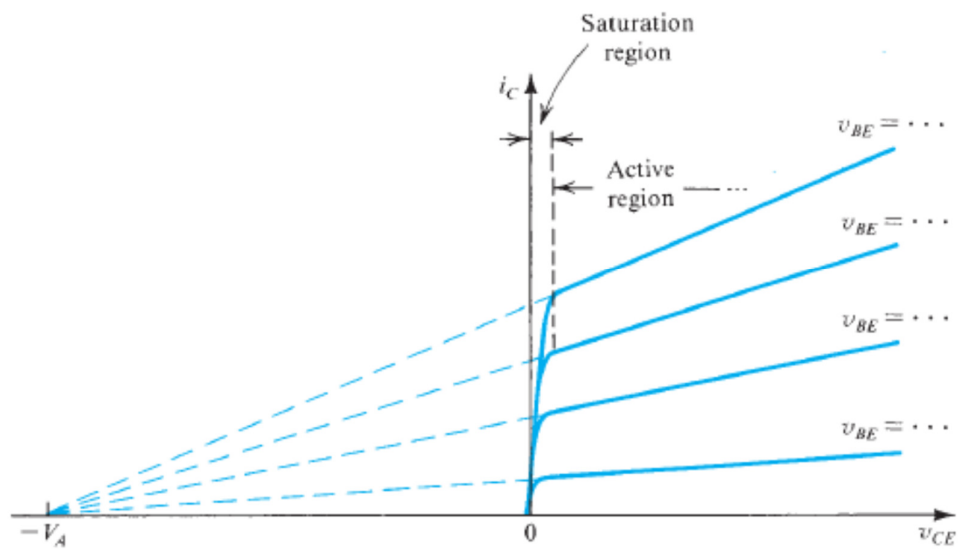

Effetto Early: V_A tensione di Early

$$i_B = \frac{i_c}{\beta} = \frac{I_C}{\beta} + \frac{i_c}{\beta} = \frac{I_C}{\beta} + \frac{1}{\beta} \frac{I_C}{V_T} v_{be} = I_B + \frac{1}{\beta} \frac{I_C}{V_T} v_{be}$$

$$i_B = I_B + i_b$$

$$\rightarrow i_b = \frac{1}{\beta} \frac{I_C}{V_T} v_{be} = \frac{g_m}{\beta} v_{be} \equiv \frac{1}{r_\pi} v_{be}$$

$$\rightarrow r_\pi = \beta \frac{V_T}{I_C} = \frac{V_T}{I_B}$$

$$i_E = I_E + i_e = \frac{i_c}{\alpha} = \frac{I_C}{\alpha} + \frac{i_c}{\alpha}$$

$$r_e \equiv \frac{v_{be}}{i_e} = \frac{i_c V_T}{i_e I_C} = \alpha \frac{V_T}{I_C} = \frac{V_T}{I_E} = \frac{\alpha}{g_m} \sim \frac{1}{g_m} \quad \text{res. equivalente di emettitore}$$

$$v_{be} = i_b r_\pi = i_e r_e \rightarrow r_\pi = \frac{i_e}{i_b} r_e \rightarrow r_\pi = (\beta + 1) r_e$$

Schema *in AC* della configurazione a emettitore comune: tensioni continue azzerate

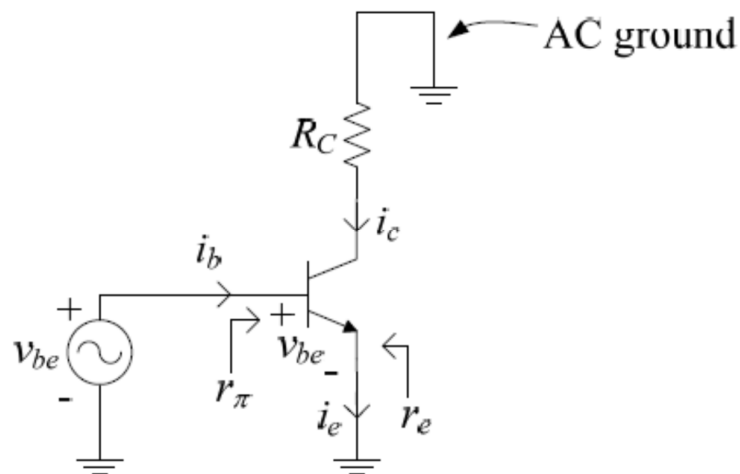

Conduce a un modello migliorato per piccoli segnali: Modello a π ibrido

Modello a π ibrido: Versione a bassa frequenza

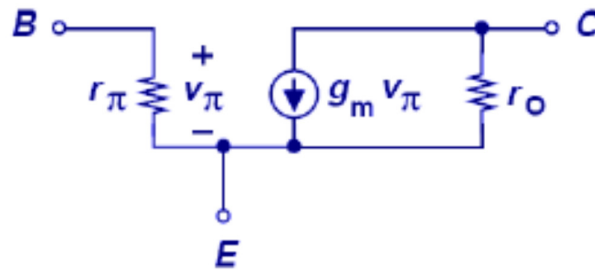

Versioni equivalenti

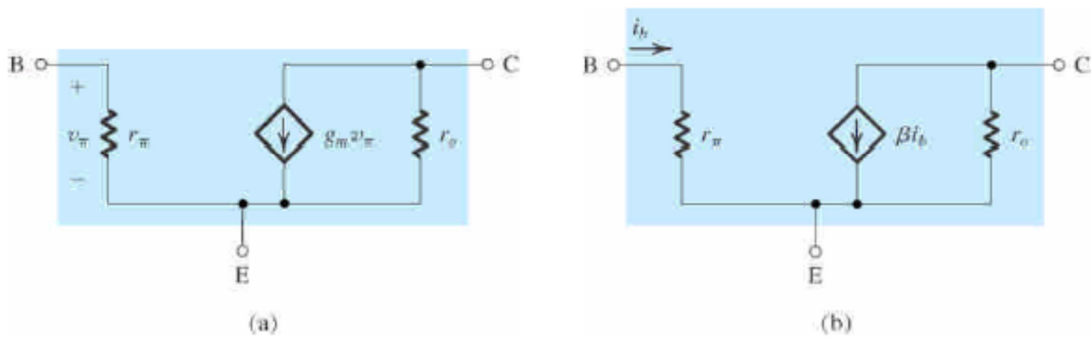

r_o legata all'effetto Early: I_C non indipendente da V_{CE}

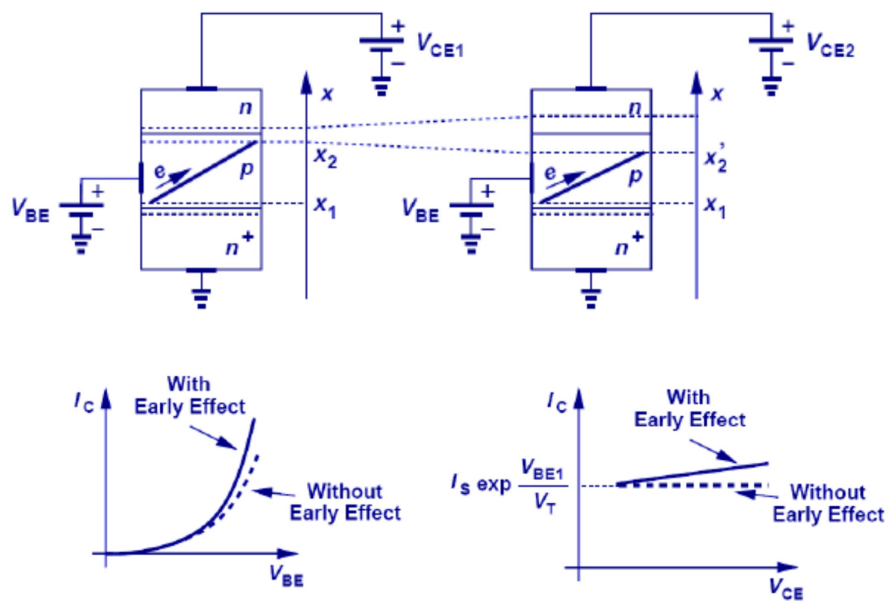

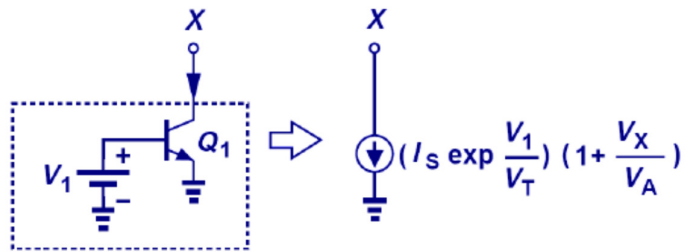

C generatore non ideale di corrente $\rightarrow r_0 < \infty$ in parallelo al generatore di corrente
 Esempio: Applicazione a stadio semplice CE

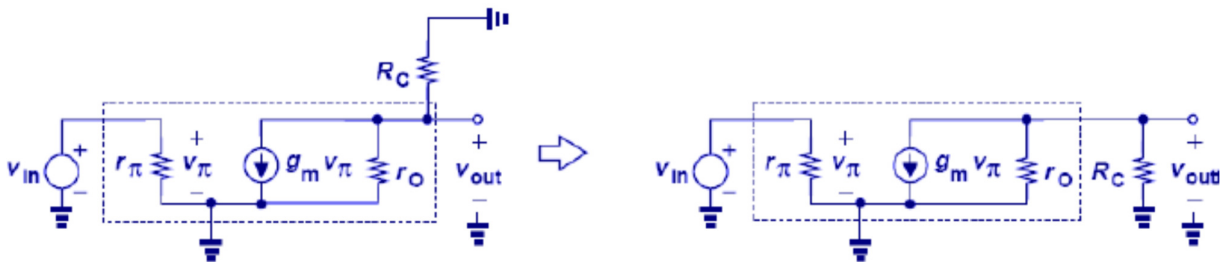
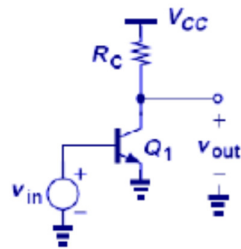

Identico per PNP:

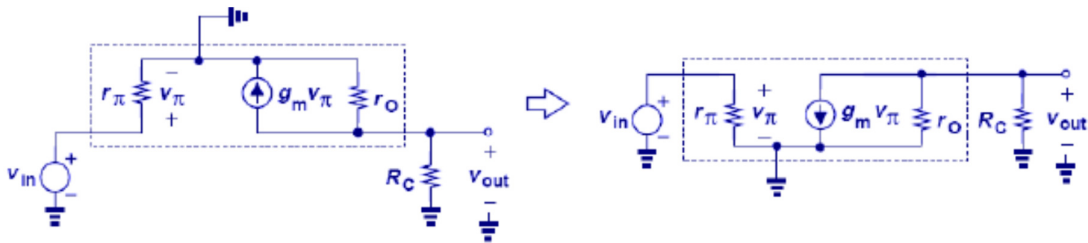
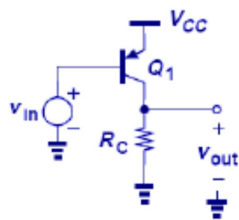

Impedenze intrinseche del BJT (in zona attiva!):

Base: Si 'guarda' dentro B

stato uscita irrilevante perche' r_π a ground

$$\rightarrow R_b = r_\pi$$

Collettore: Si 'guarda' dentro C

B (ed E) a ground $\rightarrow v_\pi = 0 \rightarrow g_m v_\pi = 0$

$$\rightarrow R_c = r_o \simeq \infty$$

Elettore : Si 'guarda' dentro E

B e C a ground $\rightarrow i_x = \frac{v_x}{r_\pi} + g_m v_\pi, v_x = v_\pi$

$$\rightarrow R_e = \frac{v_x}{i_x} = \frac{1}{g_m + \frac{1}{r_\pi}} \simeq \frac{1}{g_m}, r_o \rightarrow \infty;$$

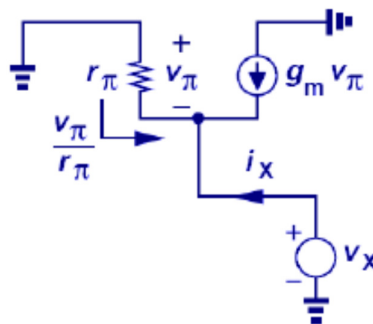
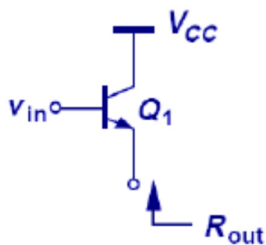
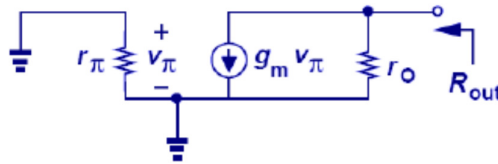
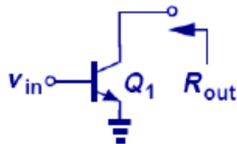
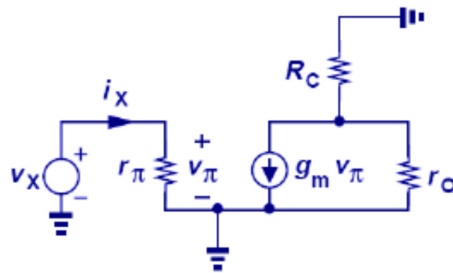
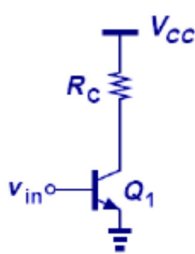

Applicazione: Stadio *CE* con resistenza su emettitore

NB: Non considerate resistenze del partitore di bias

Non considerato effetto Early

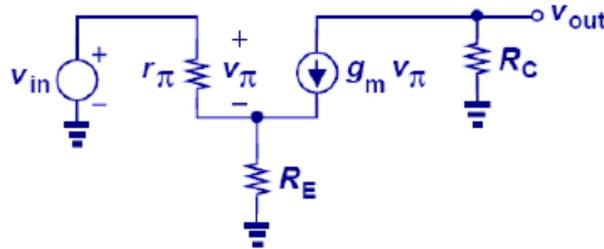

$$A_v = -\frac{v_o}{v_i} = -\frac{g_m v_\pi R_C}{v_\pi + g_m v_\pi R_E} = -\frac{g_m R_C}{1 + g_m R_E} = -\frac{R_C}{\frac{1}{g_m} + R_E} \xrightarrow{R_E \rightarrow 0} -g_m R_C$$

Impedenza di ingresso:

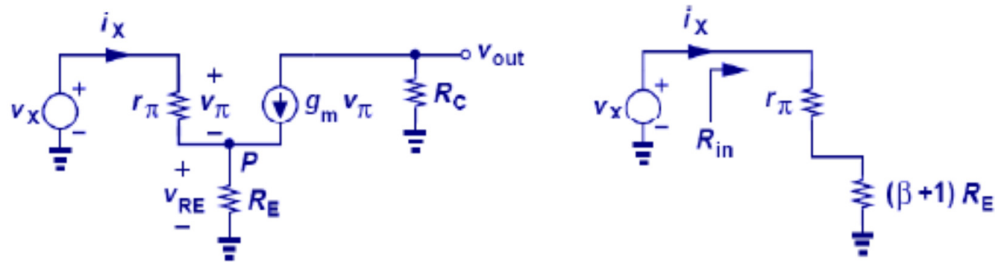

$$v_x = [r_\pi + R_E (1 + \beta)] i_x$$

$$\rightarrow R_{in} = \frac{v_x}{i_x} = r_\pi + R_E (1 + \beta) \xrightarrow{R_E \rightarrow 0} r_\pi$$

Impedenza di uscita:

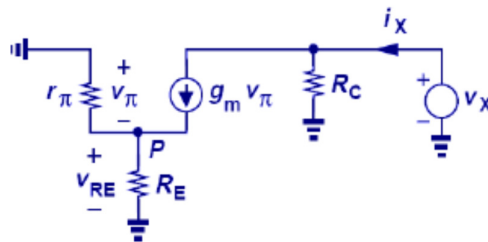

$$v_\pi + \left(\frac{v_\pi}{r_\pi} + g_m v_\pi \right) R_E = 0 \rightarrow v_\pi = 0 \rightarrow R_{out} = \frac{v_x}{i_x} = R_C$$

Tenendo conto dell'effetto Early:

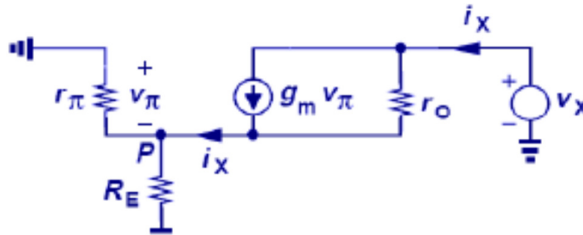
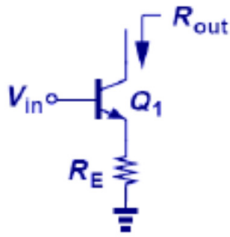

$$i_x = \frac{v_x - v_\pi}{r_o} - g_m v_\pi \quad \text{— perche' conf. invertente}$$

$$v_\pi = -i_x (R_E \parallel r_\pi) \quad \text{c.s.}$$

$$i_x = \frac{v_x}{r_o} + v_\pi \left(g_m + \frac{1}{r_o} \right)$$

$$i_x \left[1 + (R_E \parallel r_\pi) \left(g_m + \frac{1}{r_o} \right) \right] = \frac{v_x}{r_o}$$

$$\rightarrow \frac{v_x}{i_x} = r_o \left[1 + (R_E \parallel r_\pi) \left(g_m + \frac{1}{r_o} \right) \right] \quad \text{imp. di uscita}$$

$$\rightarrow R_{out} \approx r_o \left[1 + (R_E \parallel r_\pi) g_m \right] \quad g_m r_o \gg 1$$

R_{out} aumentata \rightarrow Migliorato generatore di corrente

Tenendo conto del partitore di bias:

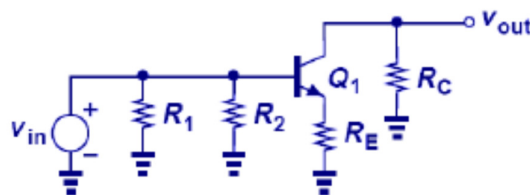
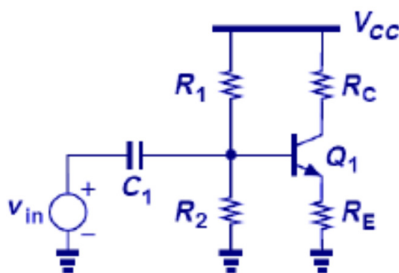

$$A_v = -\frac{R_C}{\frac{1}{g_m} + R_E}$$

$$R_{in} = [r_\pi + (\beta + 1)R_E] \parallel R_1 \parallel R_2$$

$$R_{out} = R_C$$

Al gran completo:

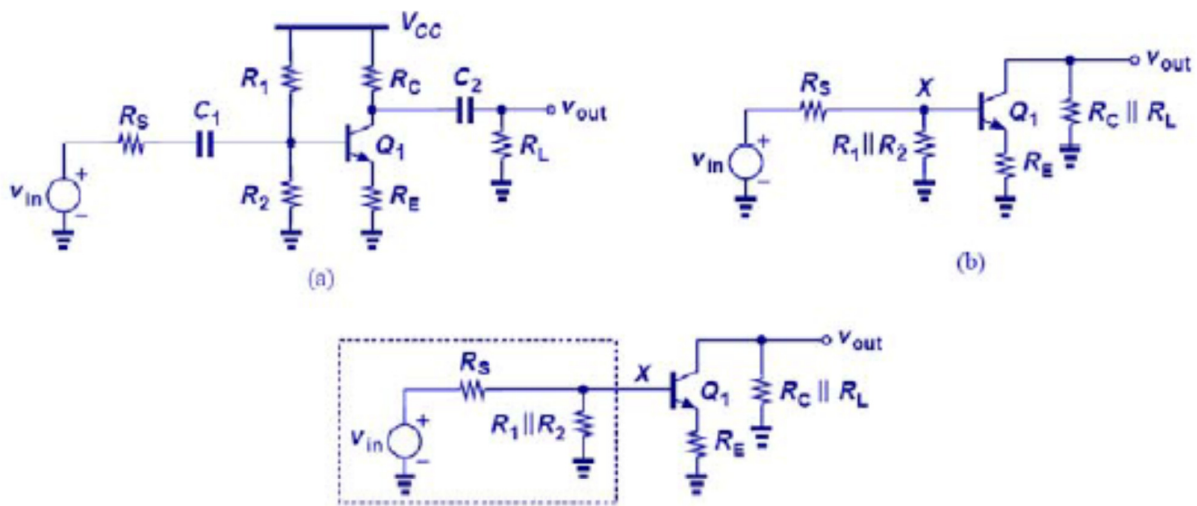

$$A_v = -\frac{R_C \parallel R_L}{\frac{1}{g_m} + R_E + \frac{R_S \parallel R_1 \parallel R_2}{\beta + 1}}$$