

## 19- BJT : Esempi di circuiti multi - stadio

### 1) Darlington

Stadio a 2 BJT: CC + CC

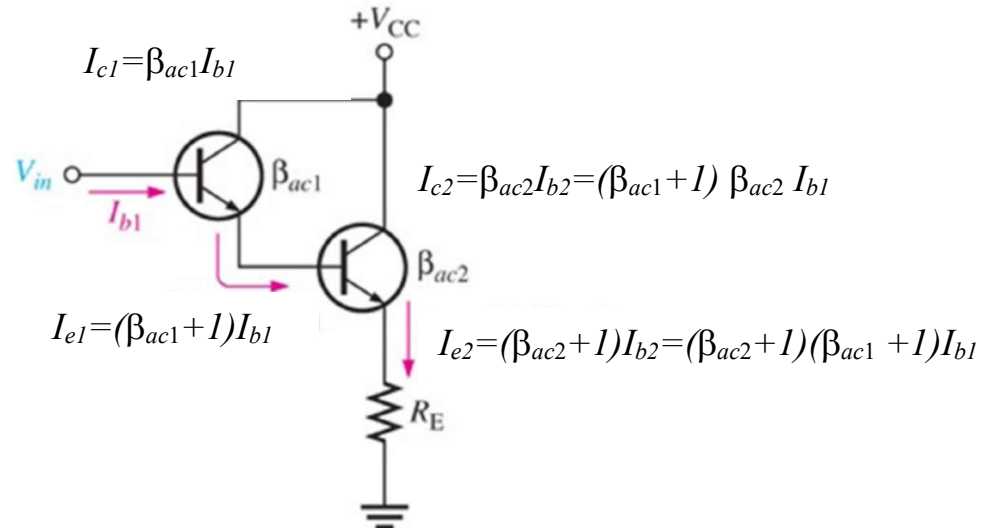

$$I_{tot} = I_{c1} + I_{c2} = (\beta_1 + \beta_2 (\beta_1 + 1)) I_{b1} = (\beta_1 \beta_2 + \beta_1 + \beta_2) I_{b1}$$

$$\beta = \beta_1 \beta_2 + \beta_1 + \beta_2$$

$$\beta_i \gg 1 \rightarrow \beta_1 \beta_2 \gg \beta_1 + \beta_2 \rightarrow \beta \approx \beta_1 \beta_2 \sim 10^4 !$$

$$\rightarrow R_{in} \sim \beta_1 \beta_2 R_E$$

Svantaggio principale:

$V_{BE} \sim 1.3 V$  per zona attiva ( $\rightarrow 2$  diodi)

Versione a 'Sziklai Pair':  $V_{BE} \sim 0.65 V$  per zona attiva ( $\rightarrow 1$  diodo)

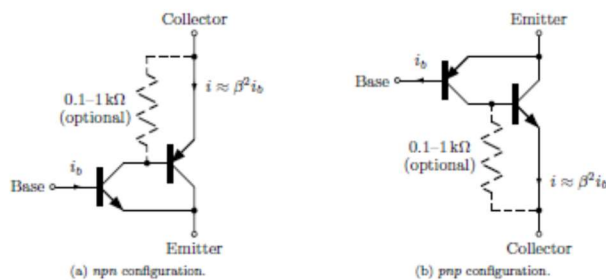

$$i = i_{E1} + i_{C2}$$

$$i_{E1} = (\beta_1 + 1) i_{B1}, i_{C2} = \beta_2 i_{B2}$$

$$i_{B2} = i_{C1} = \beta_1 i_{B1} \rightarrow i_{C2} = \beta_2 \beta_1 i_{B1}$$

$$\rightarrow i = i_{E1} + i_{C2} = (\beta_1 + 1) i_{B1} + \beta_2 \beta_1 i_{B1} = (\beta_1 + 1 + \beta_2 \beta_1) i_{B1} \text{ corr. emettitore}$$

$$\rightarrow \text{Corr. di 'collettore'} = (\beta_1 + \beta_2 \beta_1) i_{B1} \approx \beta_2 \beta_1 i_B$$

## 2) Cascode

Stadio a 2 BJT:  $CE + CB$

Alta impedenza di ingresso (CE)

Banda larga (CB) - Riduzione drastica di effetto Miller

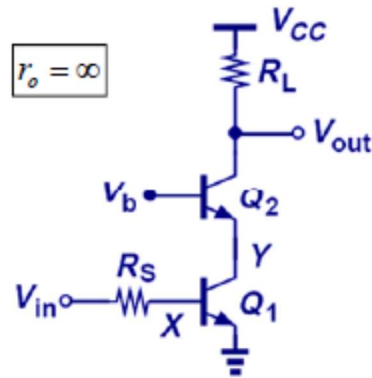

$$A_{v,XY} \equiv \frac{v_X}{v_Y} = -g_{m1} \left( \frac{1}{g_{m2}} \right) \approx -1$$

$$\Rightarrow C_X \approx 2C_{XY}$$

Identificazione capacita':

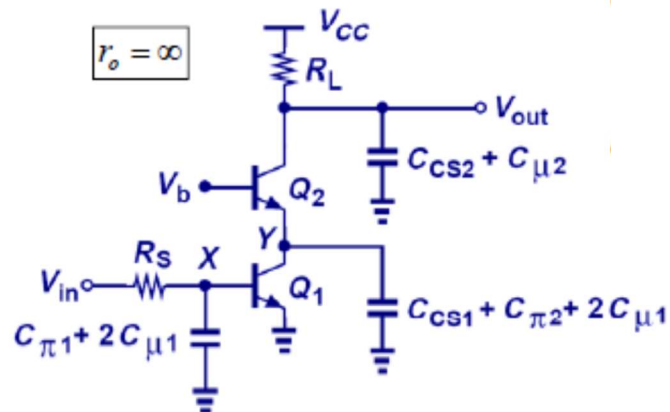

Frequenze di taglio:

$$\omega_{p,X} = \frac{1}{(R_S \parallel r_{\pi 1})(C_{\pi 1} + 2C_{\mu 1})}$$

$$\omega_{p,Y} = \frac{1}{\frac{1}{g_{m2}}(C_{CS1} + C_{\pi 2} + 2C_{\mu 1})}$$

Inoltre:

$$\omega_{p,out} = \frac{1}{R_L(C_{CS2} + C_{\mu2})}$$

Quindi:

$$Z_{in} = r_{\pi1} \parallel \frac{1}{j\omega(C_{\pi1} + 2C_{\mu1})}$$

$$Z_{out} = R_L \parallel \frac{1}{j\omega(C_{\mu2} + C_{CS2})}$$

### 3) Current mirror

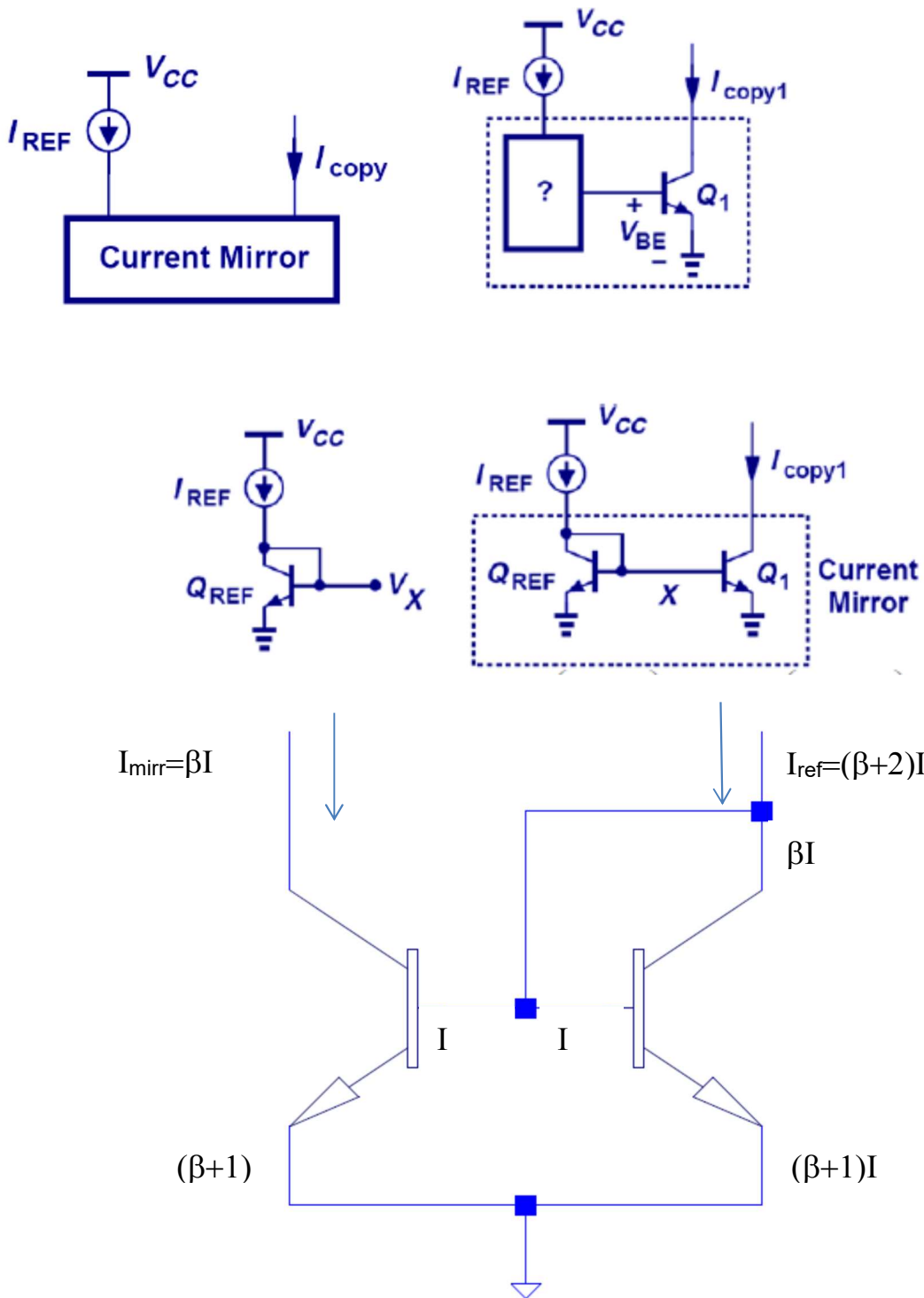

$$I_{ref} = I_{C1} + 2I, I_{C1} = \beta I \rightarrow I_{ref} = (\beta + 2)I$$

$$I_{mirr} = I_{C2} = \beta I$$

Matching fra correnti:

$$\frac{I_{mirr}}{I_{ref}} = \frac{\beta}{\beta + 2} \sim \text{OK @1-2\%}$$

Current mirror di Wilson:

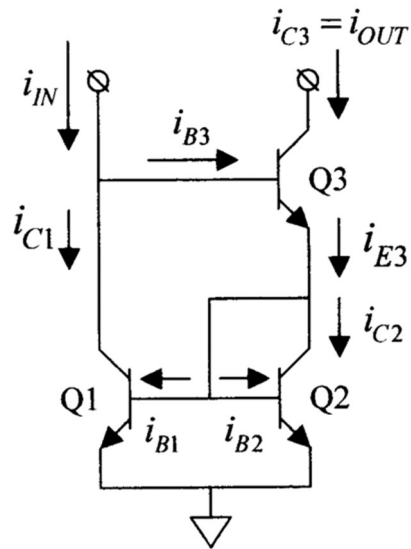

Assumendo i 3 BJT identici:

$$i_{B1} = i_{B2} \equiv I$$

$$\rightarrow i_{C1} = i_{C2} = \beta I$$

$$i_{IN} = i_{C1} + i_{B3} = \beta I + \frac{1}{\beta + 1} i_{E3}$$

$$i_{E3} = i_{C2} + 2I = (\beta + 2)I$$

$$\rightarrow i_{IN} = i_{C1} + i_{B3} = \beta I + \frac{\beta + 2}{\beta + 1} I = \left( \beta + \frac{\beta + 2}{\beta + 1} \right) I$$

$$i_{IN} = \frac{\beta(\beta + 1) + \beta + 2}{\beta + 1} I = \frac{\beta^2 + 2\beta + 2}{\beta + 1} I$$

$$i_{C3} = \frac{\beta}{\beta + 1} i_{E3} = \frac{\beta(\beta + 2)}{\beta + 1} I$$

$$\rightarrow \frac{i_{C3}}{i_{IN}} = \frac{\beta(\beta + 2)}{\beta + 1} \frac{\beta + 1}{\beta^2 + 2\beta + 2} = \frac{\beta(\beta + 2)}{\beta^2 + 2\beta + 2} \simeq 1$$

Matching entro  $\sim 10^{-4}$

#### 4) Amplificatore differenziale

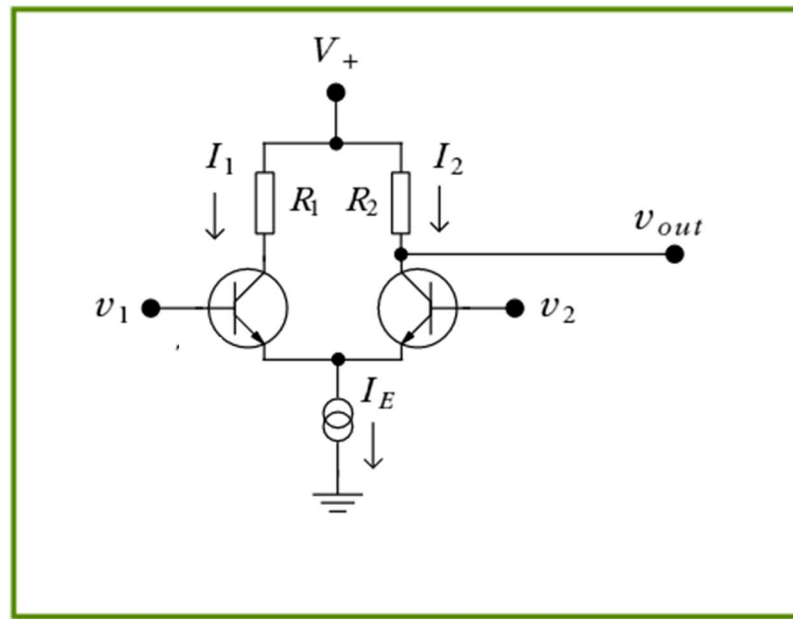

$$v_1 = v_{B1}, v_2 = v_{B2}$$

$$I = i_{E1} + i_{E2}$$

$$I_1 = i_{C1}, I_2 = i_{C2}$$

$$R_{C1} = R_1, R_{C2} = R_2$$

$$i_{E1} = \frac{I_S}{\alpha} \exp[(v_{B1} - v_E)/V_T]$$

$$i_{E2} = \frac{I_S}{\alpha} \exp[(v_{B2} - v_E)/V_T]$$

$$\frac{i_{E1}}{i_{E2}} = \exp[(v_{B1} - v_{B2})/V_T]$$

$$\frac{i_{E1}}{i_{E1} + i_{E2}} = \frac{i_{E1}}{I} = \frac{1}{1 + i_{E2}/i_{E1}} = \frac{1}{1 + \exp[(v_{B2} - v_{B1})/V_T]}$$

$$\frac{i_{E2}}{i_{E1} + i_{E2}} = \frac{i_{E2}}{I} = \frac{1}{1 + i_{E1}/i_{E2}} = \frac{1}{1 + \exp[(v_{B1} - v_{B2})/V_T]}$$

$$R_C = \frac{R_{C1} + R_{C2}}{2}$$

$$\Delta R_C = \frac{R_{C1} - R_{C2}}{2}$$

$$v_{C1} - v_{C2} = \alpha [R_{C1} i_{E1} - R_{C2} i_{E2}]$$

$$= \alpha R_C \left[ (i_{E1} - i_{E2}) + \frac{\Delta R_C}{2 R_C} (i_{E1} + i_{E2}) \right]$$

$$v_{C1} - v_{C2} = \alpha I R_C \left[ \frac{(i_{E1} - i_{E2})}{I} + \frac{\Delta R_C}{2 R_C} \right]$$

$$= \alpha I R_C \left\{ \frac{1 - \exp[(v_{B2} - v_{B1})/V_T]}{1 + \exp[(v_{B2} - v_{B1})/V_T]} + \frac{\Delta R_C}{R_C} \right\}$$

$$= \alpha I R_C \left\{ \tanh[(v_{B1} - v_{B2})/V_T] + \frac{\Delta R_C}{R_C} \right\}$$

$$v_{C1} - v_{C2} = \alpha I R_C \left[ \frac{(i_{E1} - i_{E2})}{I} + \frac{\Delta R_C}{2 R_C} \right]$$

$$= \alpha I R_C \left\{ \frac{1 - \exp[(v_{B2} - v_{B1})/V_T]}{1 + \exp[(v_{B2} - v_{B1})/V_T]} + \frac{\Delta R_C}{R_C} \right\}$$

$$= \alpha I R_C \left\{ \tanh[(v_{B1} - v_{B2})/V_T] + \frac{\Delta R_C}{R_C} \right\}$$

Matching ideale fra le res. di collettore:  $\Delta R_C = 0$

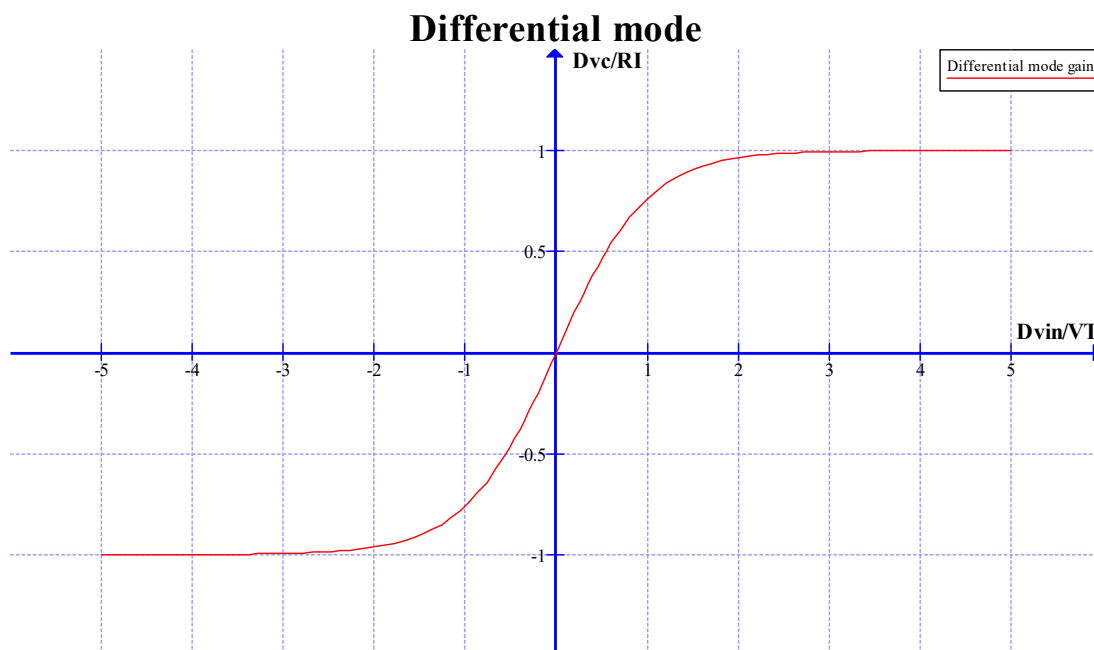

$\frac{\Delta v}{V_T} \ll 1 \rightarrow \tanh \frac{\Delta v}{V_T} \approx \frac{\Delta v}{V_T} \rightarrow$  Risposta lineare ai piccoli segnali!

$$v_{C1} - v_{C2} \approx \frac{\alpha I R_C}{V_T} (v_{B1} - v_{B2}) + \alpha I \Delta R_C$$

Guadagno di modo differenziale:

$$G_{diff} \simeq \frac{I R_C}{V_T}$$

$\alpha I \Delta R_C \simeq I \Delta R_C =$  tensione di *offset*

→ Necessita' di compensarla

Varie tecniche di compensazione (v. amplificatori operazionali)

Tensione differenziale di uscita:

$\propto$  Tensione differenziale di ingresso

→ Indipendente da tensione di modo comune in ingresso

Es.: Aggiungendo  $V_{MC}$  a entrambi gli ingressi la tensione differenziale di uscita non cambia

Proprieta' legata alla scelta di un gen. ideale di corrente collegato agli emettitori



Se gen. di corrente collegato agli emitter  $\neq$  ideale:  
 Tensione differenziale di uscita dipende anche da  $V_{MC}$   
 $\rightarrow$  2 diversi guadagni di tensione:

$$G_{diff}, G_{MC}$$

Guadagno di modo comune  $\neq 0 \rightarrow$  Problema

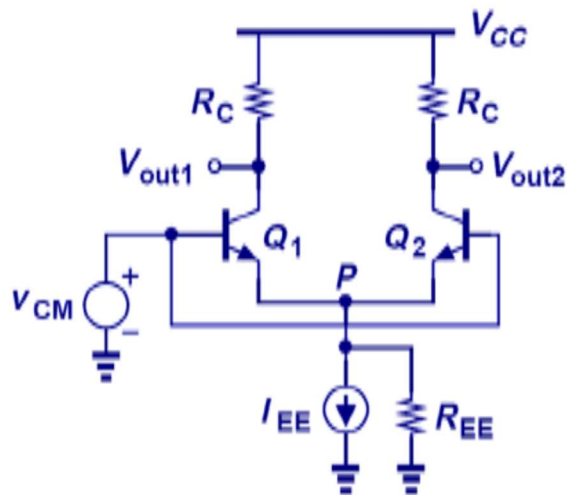

Tensione di modo comune:  
 Applicata ai due ingressi

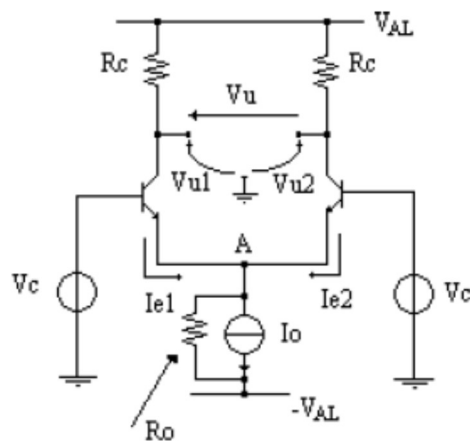

Circuito equivalente:

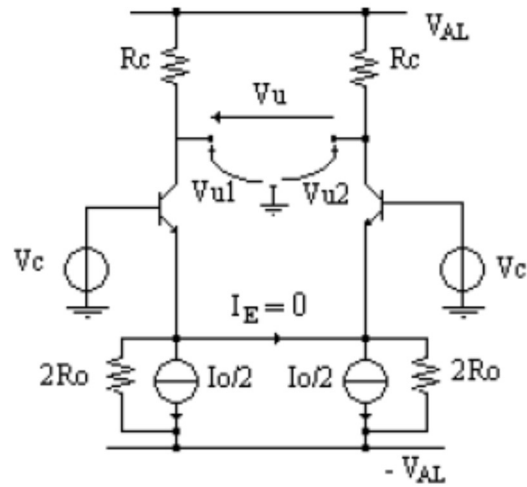

Guadagno di modo comune in caso di perfetta simmetria:

$$A_c = \frac{V_{u1}}{V_c} = \frac{V_{u2}}{V_c} = -\frac{\alpha R_c}{2R_0} \cong -\frac{R_c}{2R_0}$$

Per ridurlo  $R_0$  molto grande  $\rightarrow$  Non pratico

Miglioramenti:

a) Generatore di corrente con transistor

Es semplice:

