

Elementi di circuito bipolari (= 2 terminali) ideali:

		Impedenze	Ammettenze	
{	$R:$	$V_R(t) = Z_R i(t)$	$Z_R = R$	$Y_R = \frac{1}{R}$
	$C:$	$V_C(t) = Z_C(\omega) i(t)$	$Z_C(\omega) = \frac{1}{j\omega C}$	$Y_C = j\omega C$
	$L:$	$V_L(t) = Z_L(\omega) i(t)$	$Z_L(\omega) = j\omega L$	$Y_L = \frac{1}{j\omega L}$

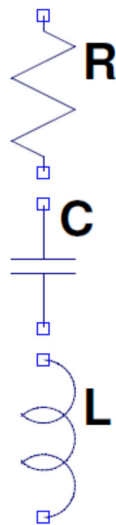

Componenti bipolari reali:

Contengono caratteristiche di ognuno dei 3 elementi ideali

Resistenza, capacita', induttanza *parassite*:

Dipendono da caratteristiche geometriche e fisiche dei componenti

Dipendono da frequenza e temperatura

Generatori ideali di tensione/corrente:

$V$  indipendente da corrente erogata (= dal carico)

$i$  indipendente da tensione sviluppata (= dal carico)

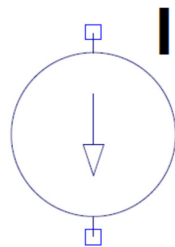
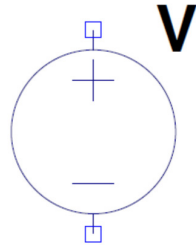

Esempi: Generatori reali  $\approx$  Generatori ideali

$V$ : Batteria

$i$ : Camera a ionizzazione

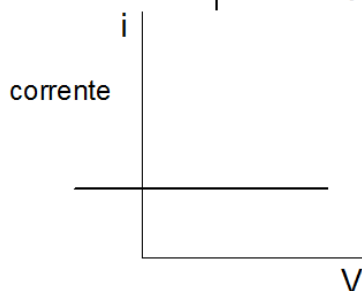
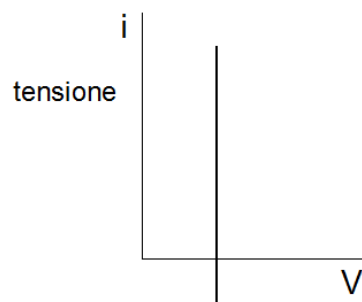

Modelli standard di generatori reali:

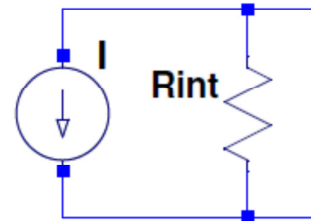
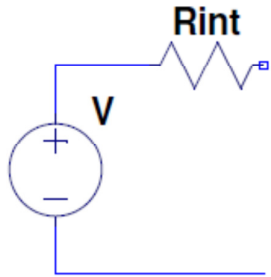

Caso di generatori in AC:

Resistenza interna  $\rightarrow$  Impedenza interna (inclusa eventuale parte reattiva)

Considerando un carico resistivo  $R_L$ :

Tensione:

$$i = \frac{V}{R_{\text{int}} + R_L} \rightarrow V_{\text{eff}} = iR_L = V \frac{R_L}{R_{\text{int}} + R_L} \simeq V \text{ se } R_{\text{int}} \ll R_L$$

$\rightarrow$  Reale  $\sim$  Ideale se  $R_{\text{int}}$  piccola

Corrente:

$$V = i \frac{R_{\text{int}} R_L}{R_{\text{int}} + R_L} \rightarrow i_{\text{eff}} = \frac{V}{R_L} = i \frac{R_{\text{int}} R_L}{R_{\text{int}} + R_L} \frac{1}{R_L} = i \frac{R_{\text{int}}}{R_{\text{int}} + R_L} \simeq i \text{ se } R_{\text{int}} \gg R_L$$

$\rightarrow$  Reale  $\sim$  Ideale se  $R_{\text{int}}$  grande

Elementi di circuito quadripolari

Quadripoli: reti con 2 coppie di (= 4) terminali

I coppia di terminali: ingresso

II coppia di terminali: uscita

Caratteristica del quadripolo: *Funzione di trasferimento*

→ Rapporto fra tensione/corrente di uscita e tensione/corrente di ingresso

→ Funzione complessa di  $\omega$

Esempio piu' semplice: Partitore di tensione resistivo

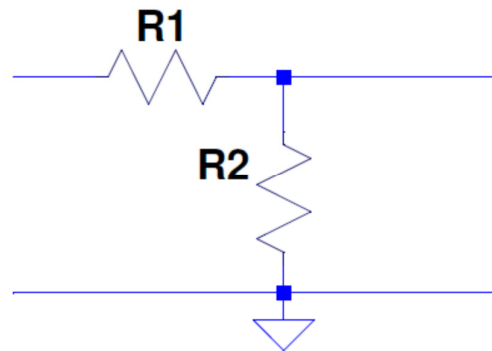

$$V_{out} = iR_2 = V_{in} \frac{R_2}{R_1 + R_2}$$

$$\rightarrow \frac{V_{out}}{V_{in}} = T = \frac{R_2}{R_1 + R_2}$$

Notare:

$T$  (funzione di trasferimento adimensionale)

rappresenta il 'guadagno di tensione' del quadripolo se

a)  $V_{in}$  si assume proveniente da un gen. di tensione ideale  $R_{gen} \rightarrow 0$

b)  $V_{out}$  si assume misurata su un carico ideale  $R_L \rightarrow \infty$

Quadripoli selettivi  $\rightarrow$  *Filtri* (passivi, analogici, a costanti concentrate)

a) Passa-basso

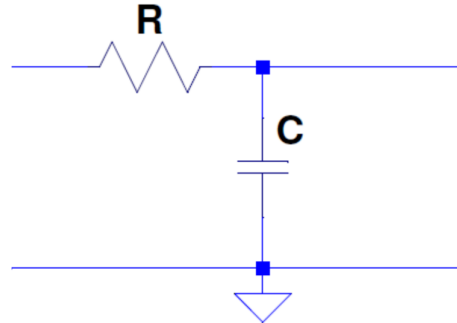

$$V_{out} = iZ_2 = V_{in} \frac{Z_2}{Z_1 + Z_2}$$

$$\rightarrow \frac{V_{out}}{V_{in}} = T = \frac{Z_2}{Z_1 + Z_2} = \frac{\frac{1}{j\omega C}}{R + \frac{1}{j\omega C}} = \frac{1}{j\omega CR + 1} \equiv T(\omega), \quad \omega_0 = \frac{1}{RC}$$

$$T(\omega) = \frac{1 - j\omega CR}{1 + \omega^2 C^2 R^2} \rightarrow |T(\omega)|^2 = \frac{1 + \omega^2 C^2 R^2}{(1 + \omega^2 C^2 R^2)^2} = \frac{1}{1 + \omega^2 C^2 R^2}$$

$$\rightarrow |T(\omega)| = \frac{1}{\sqrt{1 + \omega^2 C^2 R^2}} = \frac{1}{\sqrt{1 + \left(\frac{\omega}{\omega_0}\right)^2}}$$

$$\varphi_T = \arctan \frac{\text{Im}T}{\text{Re}T} = \arctan(-\omega CR) = -\arctan\left(\frac{\omega}{\omega_0}\right)$$

$\omega_0$  frequenza di taglio

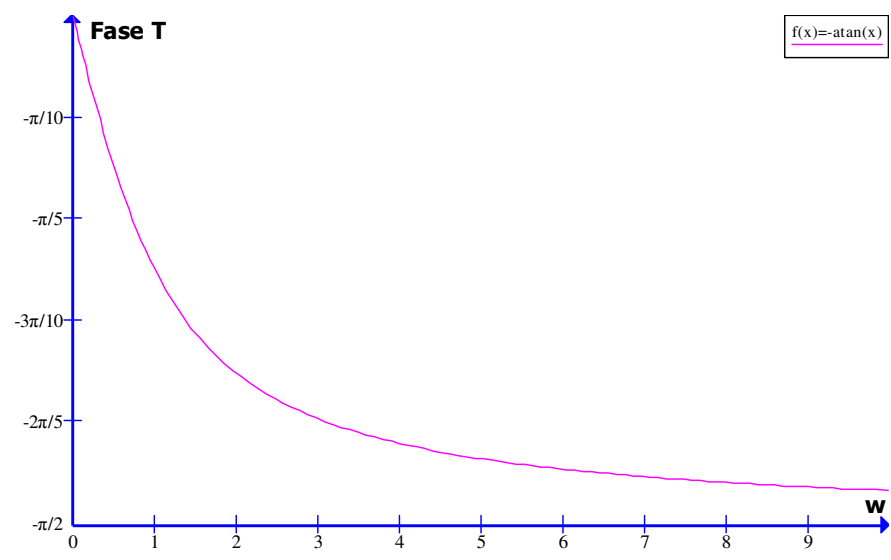
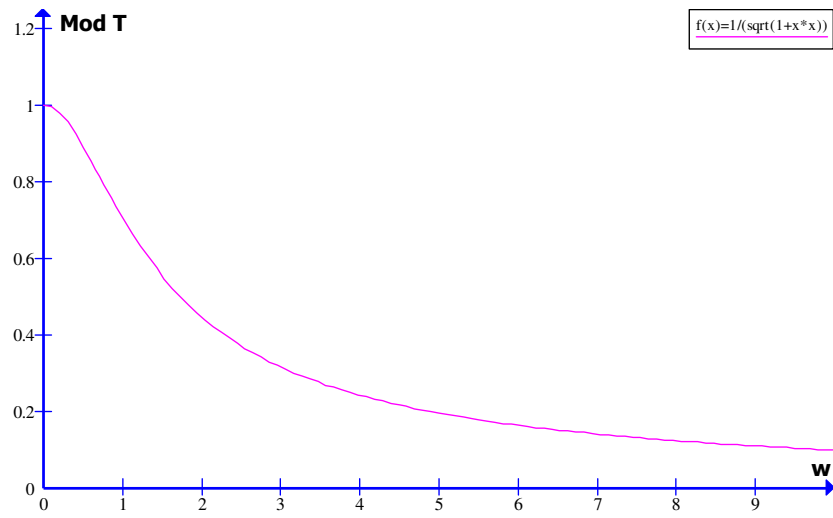

b) Altro passa-basso

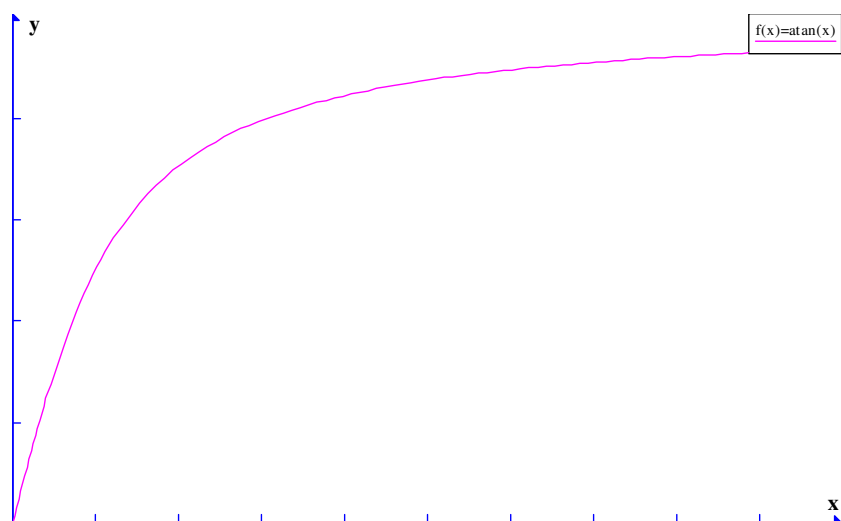
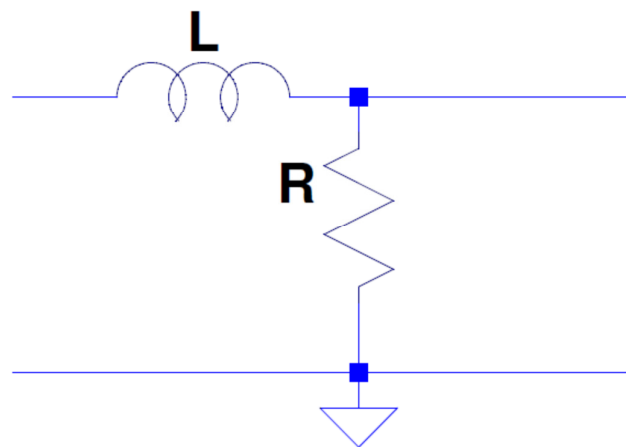

$$\omega_0 = \frac{R}{L}$$



c) Passa alto

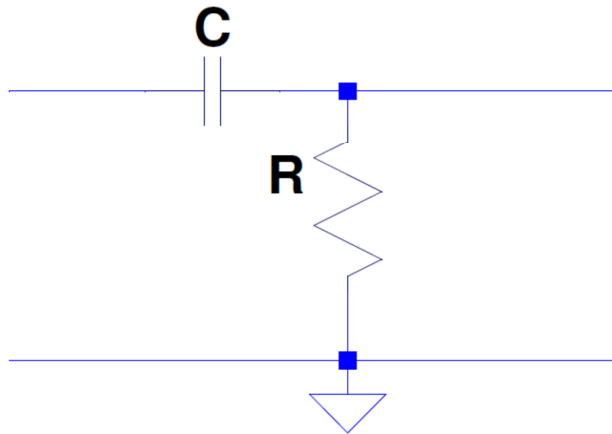

$$V_{out} = iZ_2 = V_{in} \frac{Z_2}{Z_1 + Z_2}$$

$$\rightarrow \frac{V_{out}}{V_{in}} = T = \frac{Z_2}{Z_1 + Z_2} = \frac{R}{R + \frac{1}{j\omega C}} = \frac{j\omega CR}{j\omega CR + 1} \equiv T(\omega), \quad \omega_0 = \frac{1}{RC}$$

$$T(\omega) = \frac{(1 - j\omega CR) j\omega CR}{1 + \omega^2 C^2 R^2} \rightarrow |T(\omega)|^2 = (\omega CR)^2 \frac{1 + \omega^2 C^2 R^2}{(1 + \omega^2 C^2 R^2)^2} = \frac{(\omega CR)^2}{1 + \omega^2 C^2 R^2}$$

$$\rightarrow |T(\omega)| = \frac{\omega CR}{\sqrt{1 + \omega^2 C^2 R^2}} = \frac{\frac{\omega}{\omega_0}}{\sqrt{1 + \left(\frac{\omega}{\omega_0}\right)^2}}$$

$$\varphi_T = \arctan \frac{\text{Im}T}{\text{Re}T} = \arctan \left( \frac{1}{\omega CR} \right) = \arctan \left( \frac{\omega_0}{\omega} \right)$$

$\omega_0$  frequenza di taglio

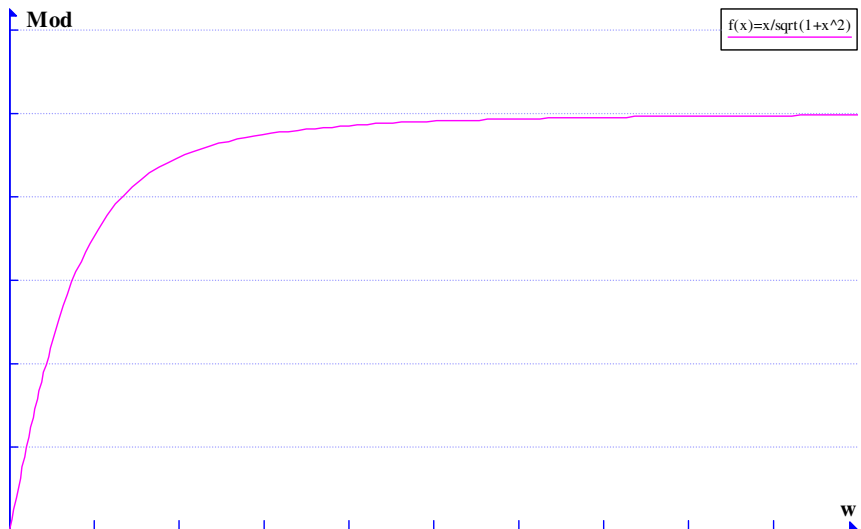
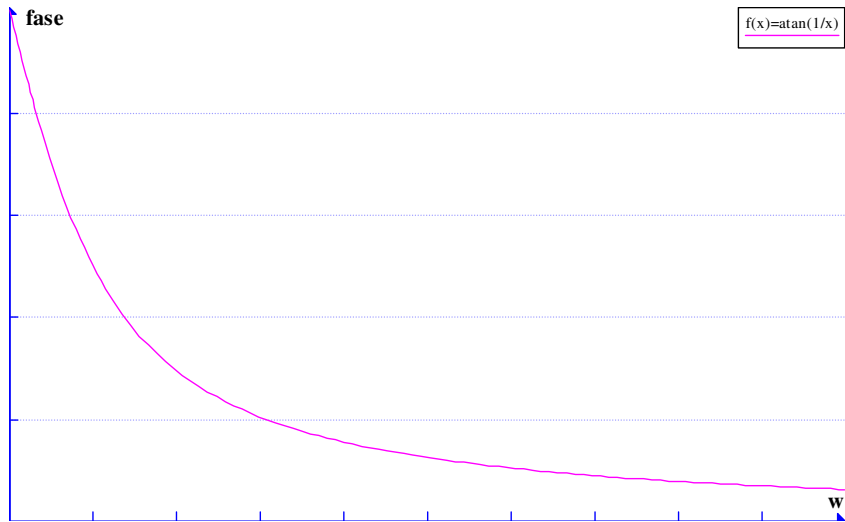

d) Altro passa-alto

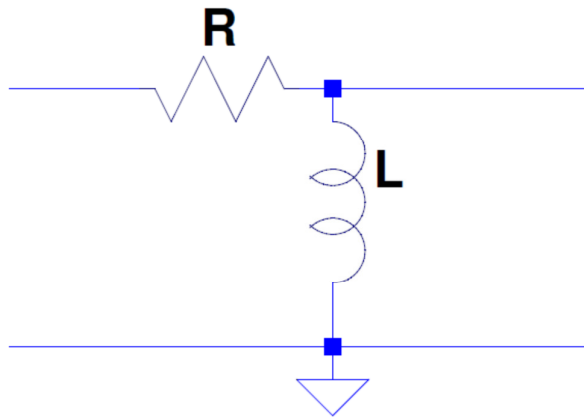

$$\omega_0 = \frac{R}{L}$$