

6 - Trasformata di Laplace

Generalizzazione della TdF

$$X(\omega) = F[x(t)] = \int_{-\infty}^{+\infty} x(t) e^{-j\omega t} dt$$

$X(\omega)$ esiste se

$$\int_{-\infty}^{+\infty} |x(t)| dt < \infty$$

Molti casi non soddisfano la condizione: Es funzione a gradino

Estensione:

$$x(t) \rightarrow x(t) e^{-\sigma t}$$

$$\int_{-\infty}^{+\infty} x(t) e^{-j\omega t} dt \rightarrow \int_{-\infty}^{+\infty} x(t) e^{-\sigma t} e^{-j\omega t} dt = \int_{-\infty}^{+\infty} x(t) e^{-(\sigma+j\omega)t} dt \equiv \int_{-\infty}^{+\infty} x(t) e^{-st} dt$$

$s = \sigma + j\omega$ frequenza complessa

Trasformata di Laplace:

$$X(s) = L[x(t)] = \int_{-\infty}^{+\infty} x(t) e^{-st} dt$$

Funzione di variabile complessa definita nel piano complesso:

asse x : $\text{Re}(s) = \sigma$

asse y : $\text{Im}(s) = \omega$

Trasformazione inversa:

$$X(s) = \int_{-\infty}^{+\infty} x(t) e^{-(\sigma+j\omega)t} dt = \int_{-\infty}^{+\infty} [x(t) e^{-\sigma t}] e^{-j\omega t} dt$$

$$\rightarrow x(t) e^{-\sigma t} = \frac{1}{2\pi} \int_{-\infty}^{+\infty} X(s) e^{+j\omega t} d\omega \rightarrow x(t) = \frac{1}{2\pi} \int_{-\infty}^{+\infty} X(s) e^{+j\omega t} e^{+\sigma t} d\omega$$

$$d\omega = \frac{ds}{j} \rightarrow \frac{1}{2\pi} \int_{-\infty}^{+\infty} X(s) e^{(\sigma+j\omega)t} d\omega = \frac{1}{2\pi j} \int_{\sigma-j\infty}^{\sigma+j\infty} X(s) e^{(\sigma+j\omega)t} ds$$

Forma piu' usata:

$$X(s) = \int_0^{+\infty} x(t) e^{-st} dt$$

Integrale solo su $t > 0$: TdL unilatera

Regione di convergenza:

Parte del piano complesso in cui $X(s)$ esiste

Es:

$$x(t) = e^{-at} \rightarrow \int_0^{+\infty} e^{-at} e^{-st} dt = \frac{1}{a + \sigma + j\omega} e^{-(a+\sigma+j\omega)t} \Big|_0^{\infty}$$

Convergenza: $a + \sigma > 0 \rightarrow \sigma > -a$

$$\rightarrow X(s) = \frac{1}{a + s}$$

Es:

$$\text{Caso limite } a = 0 \rightarrow x(t) = H(t) \rightarrow X(s) = \frac{1}{s}$$

Es:

$$x(t) = e^{-2t} + e^{-t} \cos 3t$$

$$\rightarrow x(t) = e^{-2t} + e^{-t} \frac{e^{j3t} + e^{-j3t}}{2} = e^{-2t} + \frac{1}{2} e^{-(1+j3)t} + \frac{1}{2} e^{-(1-j3)t}$$

$$\rightarrow X(s) = \int_0^{\infty} \left[e^{-2t} + \frac{1}{2} e^{-(1+j3)t} + \frac{1}{2} e^{-(1-j3)t} \right] e^{-st} dt$$

Convergenza: $\sigma > -1$

$$\rightarrow X(s) = \frac{1}{s+2} + \frac{1}{2} \frac{1}{s+(1+j3)} + \frac{1}{2} \frac{1}{s+(1-j3)}$$

$$\rightarrow X(s) = \frac{2s^2 + 5s + 12}{(s^2 + 2s + 10)(s + 2)}$$

Esempi di coppie *Funzione-Trasformata di Laplace* di uso frequente

Common Laplace Transform Pairs

Time Domain Function		Laplace Domain Function
Name	Definition*	
Unit Impulse	$\delta(t)$	1
Unit Step	$\gamma(t) \uparrow$	$\frac{1}{s}$
Unit Ramp	t	$\frac{1}{s^2}$
Parbola	t^2	$\frac{2}{s^3}$
Exponential	e^{-at}	$\frac{1}{s+a}$
Asymptotic Exponential	$\frac{1}{a}(1 - e^{-at})$	$\frac{1}{s(s+a)}$
Dual Exponential	$\frac{1}{b-a}(e^{-at} - e^{-bt})$	$\frac{1}{(s+a)(s+b)}$
Asymptotic Dual Exponential	$\frac{1}{ab} \left[1 + \frac{1}{a-b}(be^{-at} - ae^{-bt}) \right]$	$\frac{1}{s(s+a)(s+b)}$
Time multiplied Exponential	te^{-at}	$\frac{1}{(s+a)^2}$
Sine	$\sin(\omega_0 t)$	$\frac{\omega_0}{s^2 + \omega_0^2}$
Cosine	$\cos(\omega_0 t)$	$\frac{s}{s^2 + \omega_0^2}$
Decaying Sine	$e^{-at} \sin(\omega_0 t)$	$\frac{\omega_0}{(s+a)^2 + \omega_0^2}$
Decaying Cosine	$e^{-at} \cos(\omega_0 t)$	$\frac{s+a}{(s+a)^2 + \omega_0^2}$

Proprieta' fondamentali della TdL derivabili dalla definizione

Common Laplace Transform Properties

Name	Illustration
Definition of Transform	$f(t) \xrightarrow{L} F(s)$ $F(s) = \int_{0^-}^{\infty} f(t)e^{-st} dt$
Linearity	$Af_1(t) + Bf_2(t) \xrightarrow{L} AF_1(s) + BF_2(s)$
First Derivative	$\frac{df(t)}{dt} \xrightarrow{L} sF(s) - f(0^-)$
Second Derivative	$\frac{d^2 f(t)}{dt^2} \xrightarrow{L} s^2 F(s) - sf(0^-) - \dot{f}(0^-)$
n th Derivative	$\frac{d^n f(t)}{dt^n} \xrightarrow{L} s^n F(s) - \sum_{i=1}^n s^{n-i} f^{(i-1)}(0^-)$
Integral	$\int_0^t f(\lambda) d\lambda \xrightarrow{L} \frac{1}{s} F(s)$
Time Multiplication	$tf(t) \xrightarrow{L} -\frac{dF(s)}{ds}$
Time Delay	$f(t-a)\gamma(t-a) \xrightarrow{L} e^{-as}F(s)$ <p style="text-align: center;"><small>$\gamma(t)$ is unit step</small></p>
Complex Shift	$f(t)e^{-at} \xrightarrow{L} F(s+a)$
Scaling	$f\left(\frac{t}{a}\right) \xrightarrow{L} aF(as)$
Convolution Property	$f_1(t) * f_2(t) \xrightarrow{L} F_1(s)F_2(s)$
Initial Value	$\lim_{t \rightarrow 0^+} f(t) = \lim_{s \rightarrow \infty} sF(s)$
Final Value (if final value exists)	$\lim_{t \rightarrow \infty} f(t) = \lim_{s \rightarrow 0} sF(s)$

TdL: Ulteriore formalismo per la soluzione di eq. differenziali
Piu' generale di molti altri

Applicazione ai circuiti:

a) Capacita'

$$i(t) = C \frac{dv(t)}{dt}$$

$$\rightarrow I(s) = CL \left[\frac{dv(t)}{dt} \right] = CsV(s)$$

$$\rightarrow Z_C(s) = \frac{V(s)}{I(s)} = \frac{1}{sC} \quad \text{Impedenza generalizzata della capacita' } C$$

b) Induttanza

$$v(t) = L \frac{di(t)}{dt}$$

Segno +: $v(t)$ tensione ai capi di L \rightarrow opposta a *fem* autoindotta

$$\rightarrow V(s) = LL \left[\frac{di(t)}{dt} \right] = LsI(s)$$

$$\rightarrow Z_L(s) = sL \quad \text{Impedenza generalizzata della induttanza } L$$

c) Resistenza:

$$\rightarrow Z_R(s) = R$$

Impedenze generalizzate: utilizzate come le impedenze complesse

Ma: funzioni della frequenza complessa s

\rightarrow Generalizzazione delle leggi di Kirchoff

Da proprietà elementari TdL:

$$x(t) \stackrel{L}{\leftrightarrow} X(s)$$

$$\frac{dx}{dt} \stackrel{L}{\leftrightarrow} sX(s)$$

$$\int_0^t x(t') dt' \stackrel{L}{\leftrightarrow} \frac{1}{s} X(s)$$

→ Impedenze generalizzate di L e C :

$$V_C(s) = Z_C(s) I_C(s) = \frac{1}{sC} I(s)$$

$$V_L(s) = Z_L(s) I_L(s) = sLI(s)$$

→ Derivatore e Integratore ideali

Circuiti pratici: Approssimazioni

Circuiti con 1 elemento reattivo: I ordine

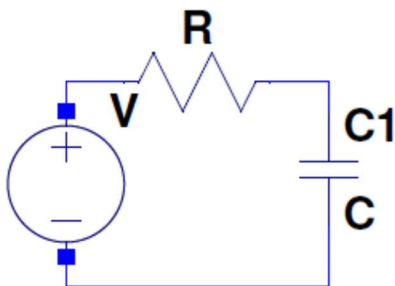

I: Derivata approx di V
 VC: Integrale approx di V
 VR: Derivata approx di V

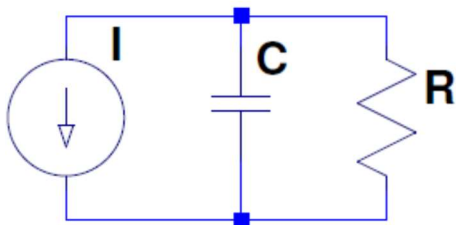

V: Integrale approx di I
 IR: Integrale approx di I
 IC: derivata approx di I

Per brevità', solo circuito RC serie: altri (RC parallelo, RL serie e parallelo) del tutto simili. Grafici rilevanti: v. lezione precedente su trattamento 'euristico'

Risposta al gradino:

$$v_{in}(t) = V_0 H(t) \rightarrow V_{in}(s) = \frac{V_0}{s}$$

Variabile di uscita: tensione su C

TdL:

$$V_{out}(s) = V_{in}(s) \frac{\frac{1}{sC}}{\frac{1}{sC} + R} = \frac{V_0}{s} \frac{1}{1 + sCR} = V_0 \left(\frac{A}{s} + \frac{B}{1 + sCR} \right)$$

$$\frac{A(1 + sCR) + Bs}{s(1 + sCR)} = \frac{s(ACR + B) + A}{s(1 + sCR)} = \frac{1}{s(1 + sCR)}$$

$$\rightarrow A = 1, A = -\frac{B}{CR} \rightarrow B = -CR$$

$$\rightarrow V_{out}(s) = V_0 \left(\frac{1}{s} - \frac{CR}{1 + sCR} \right) = V_0 \left(\frac{1}{s} - \frac{1}{\frac{1}{RC} + s} \right)$$

Anti-TdL:

$$\rightarrow v_{out}(t) = V_0 \left(H(t) - e^{-\frac{t}{CR}} \right)$$

Come atteso:

$$t \ll RC \rightarrow v_{out}(t) \approx V_0 \frac{t}{RC} \quad \text{Integrale approx di } v_{in}(t)$$

Risposta alla δ :

$$v_{in}(t) = V_0 \delta(t) \rightarrow V_{in}(s) = V_0$$

TdL:

$$V_{out}(s) = V_{in}(s) \frac{\frac{1}{sC}}{\frac{1}{sC} + R} = V_0 \frac{1}{1 + sCR}$$

Anti-TdL:

$$\rightarrow v_{out}(t) = V_0 e^{-\frac{t}{CR}}$$

Come atteso:

$$t \ll RC \rightarrow v_{out}(t) \approx V_0 \quad \text{Integrale approx di } v_{in}(t)$$

Risposta al gradino:

$$v_{in}(t) = V_0 H(t) \rightarrow V_{in}(s) = \frac{V_0}{s}$$

Variabile di uscita: tensione su R

TdL:

$$V_{out}(s) = V_{in}(s) \frac{R}{\frac{1}{sC} + R} = \frac{V_0}{s} \frac{sRC}{1 + sCR} = V_0 \left(\frac{RC}{1 + sCR} \right) = V_0 RC \frac{1}{1 + sCR}$$

Anti-TdL:

$$\rightarrow v_{out}(t) = V_0 e^{-\frac{t}{CR}}$$

Come atteso:

$$t \gg RC \rightarrow v_{out}(t) \approx 0 \text{ Derivata approx di } v_{in}(t)$$

Risposta alla δ :

$$v_{in}(t) = V_0 \delta(t) \rightarrow V_{in}(s) = V_0$$

TdL:

$$V_{out}(s) = V_{in}(s) \frac{R}{\frac{1}{sC} + R} = V_0 \frac{sCR}{1 + sCR} = V_0 \left(1 - \frac{1}{1 + sCR} \right)$$

Anti-TdL:

$$\rightarrow v_{out}(t) = V_0 \left(\delta(t) - e^{-\frac{t}{CR}} \right)$$

Come atteso:

$$t \gg RC \rightarrow v_{out}(t) \approx 0 \text{ Derivata approx di } v_{in}(t)$$

NB Derivata di $\delta(t)$?? \rightarrow 'Doppietto di Dirac'

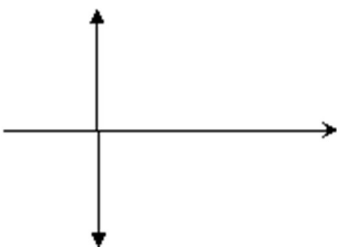

Moltiplicata per una funzione $x(t)$ e integrata produce $\frac{dx}{dt} \Big|_{t=0}$:

$$\int_{-\infty}^{+\infty} \delta'(t) x(t) dt = x(t) \delta(t) \Big|_{-\infty}^{+\infty} - \int_{-\infty}^{+\infty} \delta(t) \frac{dx}{dt} dt = \frac{dx}{dt} \Big|_{t=0}$$

Risposta a impulso rettangolare: Ampiezza V_0 , larghezza T

$$v_{in}(t) = V_0 [H(t) - H(t-T)] \rightarrow V_{in}(s) = \frac{V_0}{s} - \frac{V_0}{s} e^{-sT}$$

Variabile di uscita: tensione su R

TdL:

$$V_{out}(s) = V_{in}(s) \frac{R}{\frac{1}{sC} + R} = \frac{V_0}{s} (1 - e^{-sT}) \frac{sRC}{1 + sCR} = V_0 (1 - e^{-sT}) \left(\frac{RC}{1 + sCR} \right)$$

$$= V_0 \frac{RC}{1 + sCR} - V_0 \frac{RC}{1 + sCR} e^{-sT}$$

Anti-TdL:

$$\rightarrow v_{out}(t) = V_0 \left(e^{-\frac{t}{CR}} - e^{-\frac{t-T}{CR}} H(t-T) \right)$$

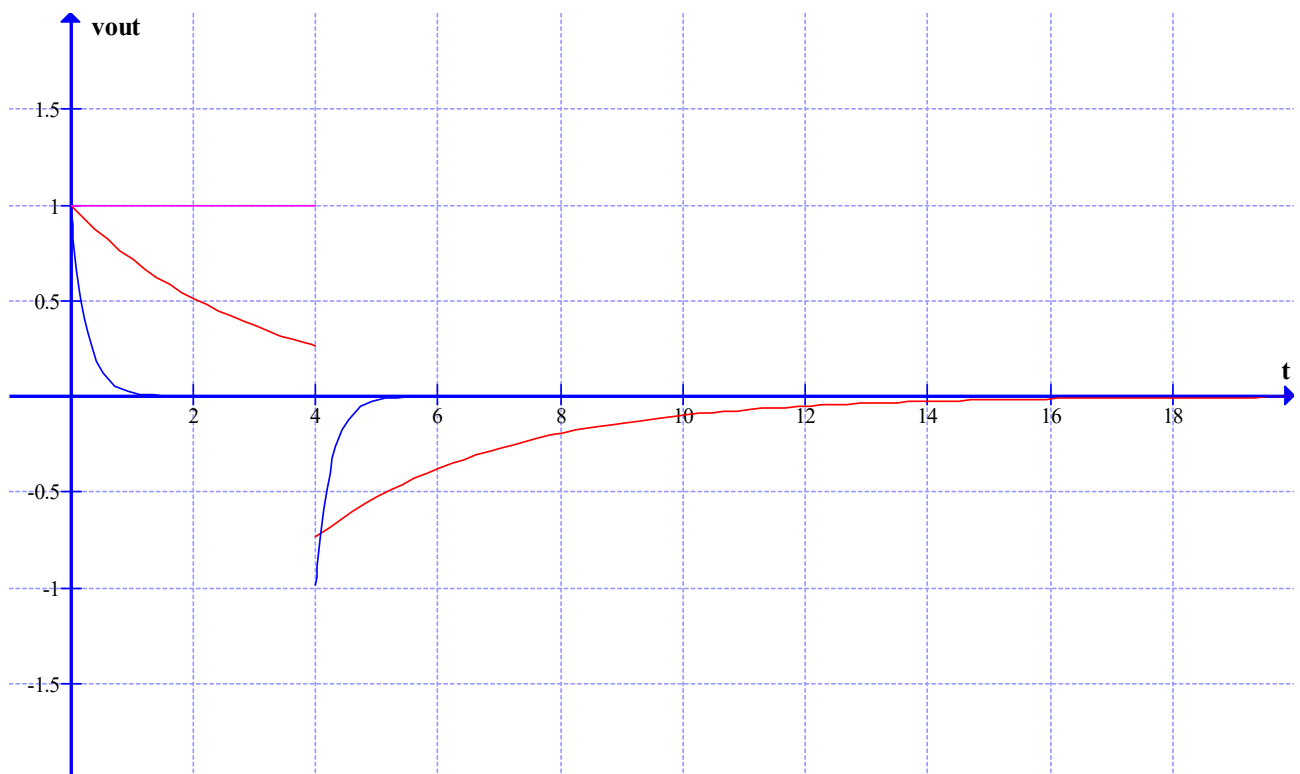

Risposta a impulso rettangolare: Ampiezza V_0 , larghezza T

$$v_{in}(t) = V_0 [H(t) - H(t-T)] \rightarrow V_{in}(s) = \frac{V_0}{s} - \frac{V_0}{s} e^{-sT}$$

Variabile di uscita: tensione su C

TdL:

$$V_{out}(s) = V_{in}(s) \frac{\frac{1}{sC}}{\frac{1}{sC} + R} = \frac{V_0}{s} (1 - e^{-sT}) \frac{1}{1 + sCR}$$

$$= \frac{V_0}{s} \frac{1}{1 + sCR} - \frac{V_0}{s} \frac{1}{1 + sCR} e^{-sT}$$

Anti-TdL:

$$\rightarrow v_{out}(t) = V_0 \left[1 - e^{-\frac{t}{CR}} - H(t-T) \left(1 - e^{-\frac{t-T}{CR}} \right) \right]$$

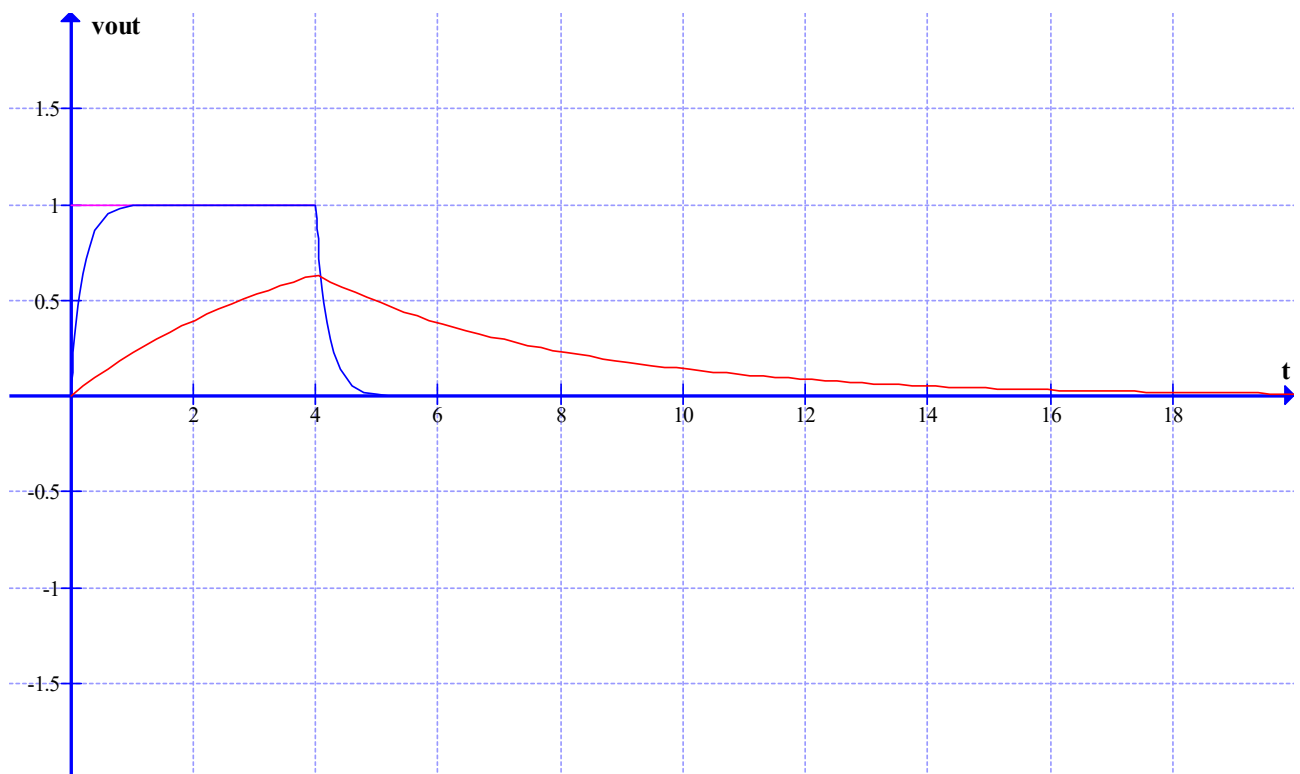

Circuito oscillante: risposta al gradino

2 elementi reattivi: circuito del II ordine

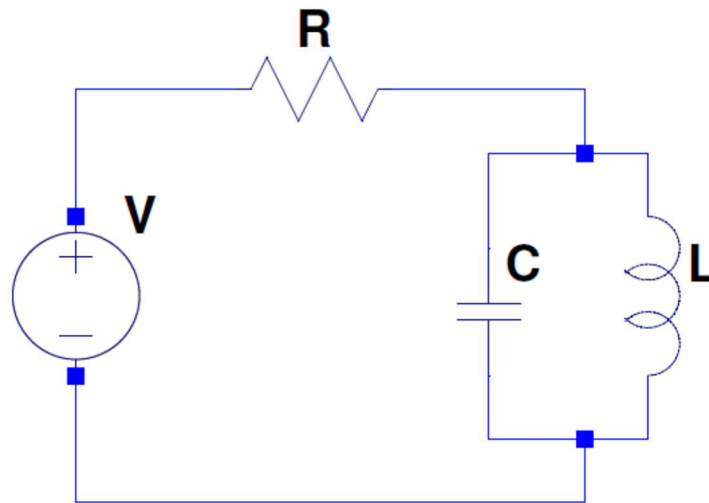

$$Z(s) = R + Z_{\parallel}(s)$$

$$Z_{\parallel}(s) = \frac{sL \frac{1}{sC}}{sL + \frac{1}{sC}} = \frac{\frac{L}{C}}{sL + \frac{1}{sC}} = \frac{sL}{s^2LC + 1}$$

$$\rightarrow Z(s) = R + \frac{sL}{s^2LC + 1}$$

$$\rightarrow V_{out}(s) = V_{in}(s) \frac{\frac{sL}{s^2LC + 1}}{R + \frac{sL}{s^2LC + 1}} = V_{in}(s) \frac{sL}{R(s^2LC + 1) + sL}$$

$$V_{in}(s) = \frac{V_0}{s} \rightarrow V_{out}(s) = V_0 \frac{L}{RLC \left(s^2 + \frac{1}{LC} + \frac{s}{RC} \right)} = V_0 \frac{1}{RC \left(s^2 + \frac{s}{RC} + \frac{1}{LC} \right)}$$

$$\omega_0 \equiv \frac{1}{\sqrt{LC}}, K \equiv \frac{1}{2R} \sqrt{\frac{L}{C}} \rightarrow 2K\omega_0 = \frac{1}{RC}$$

$$\rightarrow V_{out}(s) = V_0 \frac{1}{RC \left(s^2 + \frac{s}{RC} + \frac{1}{LC} \right)} = 2V_0 K \omega_0 \frac{1}{s^2 + 2K\omega_0 s + \omega_0^2}$$

Radici del denominatore:

$$s_{\pm} = -K\omega_0 \pm \sqrt{K^2\omega_0^2 - \omega_0^2} = -\omega_0 K \pm \omega_0 \sqrt{K^2 - 1}$$

a) $K = 1$ Smorzamento critico

$$s_+ = s_- = -\omega_0$$

$$\rightarrow V_{out}(s) = 2V_0 K \omega_0 \frac{1}{(s + \omega_0)^2} = 2V_0 \omega_0 \frac{1}{(s + \omega_0)^2}$$

$$\rightarrow v_{out}(t) = 2V_0 K \omega_0 t e^{-\omega_0 t} = 2V_0 \omega_0 t e^{-\omega_0 t}$$

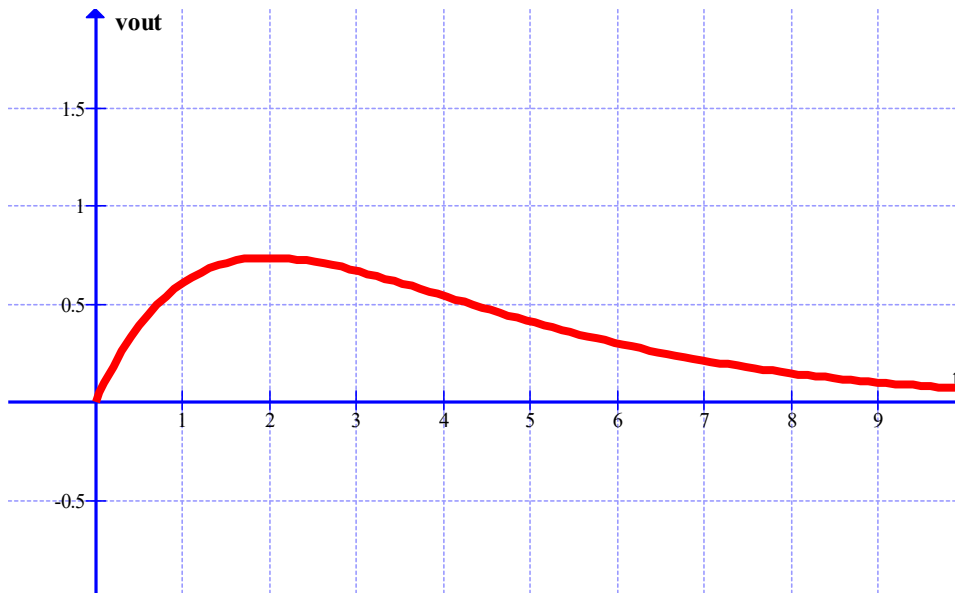

b) $K > 1$ Smorzamento

$$s_{\pm} = -K\omega_0 \pm \sqrt{K^2\omega_0^2 - \omega_0^2} = -\omega_0 \left(K \pm \sqrt{K^2 - 1} \right)$$

$$\rightarrow V_{out}(s) = 2V_0K\omega_0 \frac{1}{\left[s + \omega_0 \left(K + \sqrt{K^2 - 1} \right) \right] \left[s + \omega_0 \left(K - \sqrt{K^2 - 1} \right) \right]}$$

$$\frac{1}{\left[s + \omega_0 \left(K + \sqrt{K^2 - 1} \right) \right] \left[s + \omega_0 \left(K - \sqrt{K^2 - 1} \right) \right]} = \frac{A}{s + \omega_0 \left(K + \sqrt{K^2 - 1} \right)} + \frac{B}{s + \omega_0 \left(K - \sqrt{K^2 - 1} \right)}$$

$$A \left[s + \omega_0 \left(K - \sqrt{K^2 - 1} \right) \right] + B \left[s + \omega_0 \left(K + \sqrt{K^2 - 1} \right) \right] = 1$$

$$(A + B)s = 0 \rightarrow B = -A$$

$$\rightarrow A\omega_0 \left[K - \sqrt{K^2 - 1} - K - \sqrt{K^2 - 1} \right] = 1 \rightarrow A = -\frac{1}{2\omega_0\sqrt{K^2 - 1}}$$

$$\rightarrow V_{out}(s) = 2V_0K\omega_0 \left[\frac{-\frac{1}{\omega_0 2\sqrt{K^2 - 1}}}{s + \omega_0 \left(K + \sqrt{K^2 - 1} \right)} + \frac{\frac{1}{\omega_0 2\sqrt{K^2 - 1}}}{s + \omega_0 \left(K - \sqrt{K^2 - 1} \right)} \right]$$

$$\rightarrow V_{out}(s) = V_0 \frac{K}{\sqrt{K^2 - 1}} \left[\frac{1}{s + \omega_0 \left(K - \sqrt{K^2 - 1} \right)} - \frac{1}{s + \omega_0 \left(K + \sqrt{K^2 - 1} \right)} \right]$$

$$\rightarrow v_{out}(t) = V_0 \frac{K}{\sqrt{K^2 - 1}} \left[e^{-\omega_0 \left(K - \sqrt{K^2 - 1} \right) t} - e^{-\omega_0 \left(K + \sqrt{K^2 - 1} \right) t} \right]$$

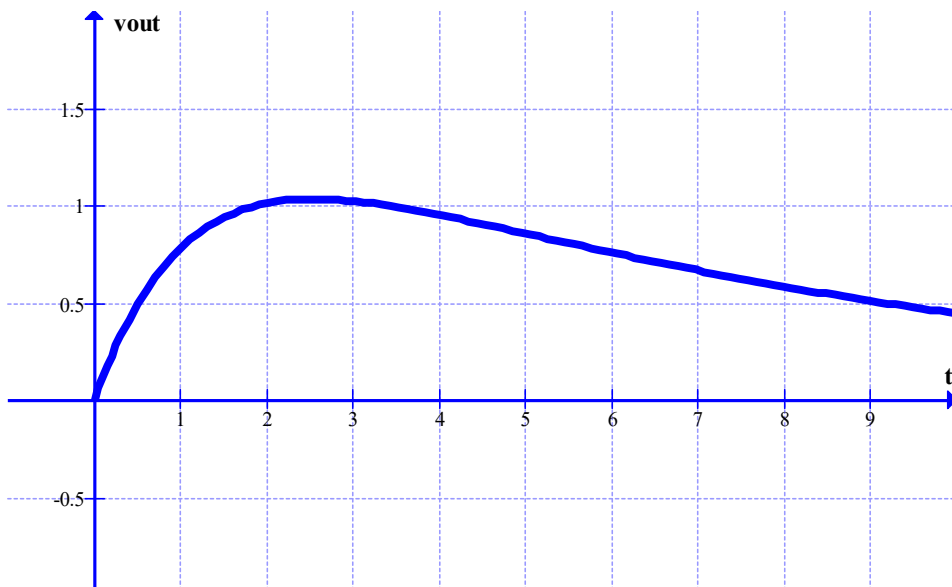

c) $K < 1$ Oscillazioni smorzate

$$s_{\pm} = -K\omega_0 \pm \sqrt{K^2\omega_0^2 - \omega_0^2} = -\omega_0 \left(K \pm i\sqrt{1-K^2} \right)$$

$$\rightarrow V_{out}(s) = 2V_0K\omega_0 \frac{1}{\left[s + \omega_0 \left(K + i\sqrt{1-K^2} \right) \right] \left[s + \omega_0 \left(K - i\sqrt{1-K^2} \right) \right]}$$

$$\frac{1}{\left[s + \omega_0 \left(K + i\sqrt{1-K^2} \right) \right] \left[s + \omega_0 \left(K - i\sqrt{1-K^2} \right) \right]} = \frac{A}{s + \omega_0 \left(K + i\sqrt{1-K^2} \right)} + \frac{B}{s + \omega_0 \left(K - i\sqrt{1-K^2} \right)}$$

$$A \left[s + \omega_0 \left(K - i\sqrt{1-K^2} \right) \right] + B \left[s + \omega_0 \left(K + i\sqrt{1-K^2} \right) \right] = 1$$

$$(A+B)s = 0 \rightarrow A+B=0 \rightarrow B=-A$$

$$\rightarrow A\omega_0 \left[K - i\sqrt{1-K^2} - K - i\sqrt{1-K^2} \right] = 1 \rightarrow A = -\frac{1}{2i\omega_0\sqrt{1-K^2}} = \frac{i}{2\omega_0\sqrt{1-K^2}}$$

$$\rightarrow V_{out}(s) = 2V_0K\omega_0 \frac{\frac{i}{2\omega_0\sqrt{1-K^2}}}{s + \omega_0 \left(K + i\sqrt{1-K^2} \right)} - 2V_0K\omega_0 \frac{\frac{i}{2\omega_0\sqrt{1-K^2}}}{s + \omega_0 \left(K - i\sqrt{1-K^2} \right)}$$

$$\rightarrow V_{out}(s) = \frac{iV_0K}{\sqrt{1-K^2}} \left[\frac{1}{s + \omega_0 \left(K - i\sqrt{1-K^2} \right)} - \frac{1}{s + \omega_0 \left(K + i\sqrt{1-K^2} \right)} \right]$$

$$\rightarrow v_{out}(t) = \frac{iV_0K}{\sqrt{1-K^2}} \left[e^{-\omega_0 \left(K - i\sqrt{1-K^2} \right) t} - e^{-\omega_0 \left(K + i\sqrt{1-K^2} \right) t} \right] = \frac{2V_0K}{\sqrt{1-K^2}} e^{-\omega_0 K t} \sin \left(\sqrt{1-K^2} \omega_0 t \right)$$

