

# Chapter 1

---

## STRUCTURE OF LIE ALGEBRAS

### 1.1 Introduction

In this Chapter ...

Goal of classifying the complexified Lie algebras. As for groups, try to single out “building blocks”, that will be (semi)-simple Lie algebras. Classification of complex simple algebras completely known, 4 families plus 5 exceptional cases. ...

#### 1.1.1 Complexified Lie algebras

A complex or complexified Lie algebra  $\mathbb{G}_c$  is a Lie algebra that as a vector space is defined over  $\mathbb{C}$ . The generators can be linearly combined with complex coefficients, and changes of basis are effected by complex matrices in  $GL(n, \mathbb{C})$ . Therefore, more sets of structure constants are related by a change of basis, and the classes of isomorphic algebras are larger.

*Example* The complexification of the Lie algebra of real matrices  $gl(n, \mathbb{R})$  is, of course, the Lie algebra of complex matrices  $gl(n, \mathbb{C})$ ; similarly the algebra of complex traceless matrices  $sl(n, \mathbb{C})$  is the complexification of  $sl(n, \mathbb{R})$ .

Consider the algebra  $sl(2, \mathbb{C})$ , whose elements are matrices of the form

$$m = m^0 L_0 + m^+ L_+ + m^- L_-, \quad m^0, m^{\pm 1} \in \mathbb{C}, \quad (1.1.1)$$

where the generators  $L_0$  and  $L_{\pm}$  were introduced in Eq. (??).

The Lie algebra  $sl(2, \mathbb{C})$  is isomorphic to the complexification of the Lie algebra  $su(2)$ , defined in Eq.s (??,??) which, in turn, was already isomorphic as a real Lie algebra to  $so(3)$ . Indeed, the generators  $L_0, L_{\pm}$  are related by a complex change of basis to the generators  $t_i = -i/2 \sigma^i$  of  $su(2)$ :

$$\begin{aligned} L_0 &= \sigma_3 = 2i t_3, \\ L_{\pm} &= \frac{\sigma^1 \pm i\sigma^2}{2} = i(t_1 \pm it_2). \end{aligned} \quad (1.1.2)$$

The inverse relation is that

$$\begin{aligned} t_3 &= -\frac{i}{2} L_0, \\ t_1 &= -\frac{i}{2} (L_+ + L_-), \end{aligned}$$

$$t_2 = -\frac{1}{2}(L_+ - L_-). \quad (1.1.3)$$

Thus the complex algebra  $\mathfrak{sl}(2, \mathbb{C})$  admits different *real sections*, namely different real Lie algebras obtained by taking *real* linear combinations of three independent generators, chosen as certain specific (in general complex) combinations of the  $L_0, L_{\pm}$  generators. If we allow only real linear combinations of  $L_0, L_{\pm}$  we obtain  $\mathfrak{sl}(2, \mathbb{R})$ ; if we allow only real combinations of the generators  $t_i$  of Eq. (??) we obtain  $\mathfrak{su}(2)$ . As an exercise, define the real section that leads to the Lie algebra  $\mathfrak{su}(1, 1)$  (the Lie algebra of the group  $SU(1, 1)$ ).

### 1.1.1.1 Real sections

... choice of an involutive automorphism.

## 1.2 Some important structures in Lie algebras

...

### 1.2.1 Subalgebras and ideals

Let us investigate the most important substructures that may appear in a Lie algebra  $\mathbb{G}$ . We will remark the relations of these substructures to substructures of the Lie group that is obtained upon exponentiation of  $\mathbb{G}$ . We will in particular introduce the notions of Lie subalgebra and of *ideal*.

#### 1.2.1.1 Lie subalgebras

Given a Lie algebra  $\mathbb{G}$ , a subspace  $\mathbb{H} \subset \mathbb{G}$  is a Lie subalgebra of  $\mathbb{G}$  iff it is by itself a Lie algebra. Namely, we must have (in symbolic notation):

$$[\mathbb{H}, \mathbb{H}] \subseteq \mathbb{H}. \quad (1.2.4)$$

Under the exponential map, a Lie subalgebra generates a Lie subgroup:

$$\mathbb{H} \subset \mathbb{G} \xrightarrow{\text{exp}} H = e^{\mathbb{H}} \subset G = e^{\mathbb{G}}, \quad (1.2.5)$$

with  $H$  a subgroup of  $G$ . Indeed,  $\forall x, y \in \mathbb{H}$ , the group product of the corresponding group elements:

$$e^x e^y = \exp \left( x + y + \frac{1}{2} [x, y] + \frac{1}{12} ([x, [x, y]] + [[x, y], y]) + \dots \right) = e^z, \quad \text{with } z \in \mathbb{H}, \quad (1.2.6)$$

where we used the Baker-Campbell-Hausdorff formula Eq. (??). Indeed, the result of all commutators above stay in  $\mathbb{H}$ , by the definition Eq. (1.2.4).

Every generator  $L$  of a Lie algebra gives rise to an abelian subalgebra  $\{\lambda L\}$ , with  $\lambda \in \mathbb{R}$ , that exponentiates to a one-parameter abelian subgroup of  $G$ .

1.2.1.2 Ideals

An ideal  $\mathcal{I} \subset \mathbb{G}$  is a subalgebra such that

$$[\mathcal{I}, \mathbb{G}] \subseteq \mathcal{I}. \tag{1.2.7}$$

That is, commuting an element of  $\mathcal{I}$  with any element of  $\mathbb{G}$  we obtain again an element of  $\mathcal{I}$  (in general a different one).

An ideal of  $\mathbb{G}$  exponentiates to an *invariant subgroup*

$$I = e^{\mathcal{I}} \subset G \tag{1.2.8}$$

of  $G$ . Indeed,  $\forall h \in \mathcal{I}, \forall x \in \mathbb{G}$ , we have

$$e^{-x}e^he^x = \exp(e^{-x}he^x) = \exp\left(h - [x, h] + \frac{1}{2}[x, [x, h]] + \dots\right) = e^{h'}, \quad \text{with } h' \in \mathcal{I}. \tag{1.2.9}$$

We used the properties Eq.s (1.2.1, 1.2.2) of the exponential map, and the fact that  $[x, h] \in \mathcal{I}$ , so that also  $[x, [x, h]] \in \mathcal{I}$ , and so on.

Let us note a couple of simple properties of ideals.

- i) If  $\mathcal{I}, \mathcal{I}'$  are ideals of  $\mathbb{G}$ , then also  $\mathcal{I} + \mathcal{I}'$  (i.e. the subspace obtained as the direct sum of the subspaces  $\mathcal{I}$  and  $\mathcal{I}'$ ) is an ideal. Indeed,  $\forall x \in \mathcal{I}, \forall x' \in \mathcal{I}'$  and  $\forall y \in \mathbb{G}$ , we have

$$[x + x', y] = [x, y] + [x', y] \in \mathcal{I} + \mathcal{I}', \tag{1.2.10}$$

since  $[x, y] \in \mathcal{I}$  and  $[x', y] \in \mathcal{I}'$ .

- ii) If  $\mathcal{I}, \mathcal{I}'$  are ideals of  $\mathbb{G}$ , then also  $[\mathcal{I}, \mathcal{I}']$  (namely the subspace spanned by all commutators between elements of the two ideals) is an ideal. Indeed,  $\forall x \in \mathcal{I}, \forall x' \in \mathcal{I}'$  and  $\forall y \in \mathbb{G}$ , we have, using the Jacobi identity,

$$[[x, x'], y] = -[[x', y], x] - [[y, x], x'] \in [\mathcal{I}, \mathcal{I}'], \tag{1.2.11}$$

since  $[x, y] \in \mathcal{I}$  and  $[x', y] \in \mathcal{I}'$ .

1.2.1.3 Center of a Lie algebra

The center  $Z(\mathbb{G})$  of a Lie algebra  $\mathbb{G}$  is the subalgebra such that

$$[Z(\mathbb{G}), \mathbb{G}] = 0. \tag{1.2.12}$$

Elements of the center of the Lie algebra exponentiate to elements in the center of the Lie group  $G$ :  $\forall z \in Z(\mathbb{G}), \forall y \in \mathbb{G}$ ,

$$e^{-y}e^ze^y = \exp(e^{-y}ze^y) = \exp\left(z - [z, y] + \frac{1}{2}[y, [y, z]] + \dots\right) = e^z, \tag{1.2.13}$$

all the commutator terms vanish because of Eq. (1.2.12).

1.2.1.4 The derived algebra

The derived algebra  $D\mathbb{G}$  of a Lie algebra  $\mathbb{G}$  is the subspace spanned by all commutators:

$$D\mathbb{G} = [\mathbb{G}, \mathbb{G}] . \tag{1.2.14}$$

The derived algebra exponentiates to the derived group  $DG$ , namely the group generated by all group commutators. In fact, every group commutator in  $G$  can be written as follows:

$$e^x e^y e^{-x} e^{-y} = \exp(e^x y e^{-x}) e^{-y} = \exp(y + \text{comm.s}) e^{-y} = \exp(\text{comm.s}) = e^z , \quad z \in D\mathbb{G} . \tag{1.2.15}$$

The derived algebra  $D\mathbb{G}$  is clearly an ideal of  $\mathbb{G}$ , as  $[D\mathbb{G}, \mathbb{G}] \subseteq D\mathbb{G}$  by the definition Eq. (1.2.14). Let us further notice the following simple facts.

- i) If  $\mathbb{G}$  is Abelian, we obviously have  $D\mathbb{G} = 0$ ;
- ii) At the opposite, there are many instances of Lie algebras such that  $D\mathbb{G} = \mathbb{G}$ , namely, all elements can be written as commutators. For instance, in the  $\text{su}(2)$  algebra we have

$$t_1 = [t_2, t_3] , \quad t_2 = [t_3, t_1] , \quad t_3 = [t_1, t_2] . \tag{1.2.16}$$

1.2.1.5 Normalizer

The normalizer  $\mathcal{N}(K)$  of a subspace  $K \subset \mathbb{G}$  is the subspace of  $\mathbb{G}$  for which  $K$  behaves like an ideal:

$$\mathcal{N}(K) = \{x \in \mathbb{G} : [K, x] \subseteq K\} . \tag{1.2.17}$$

The normalizer  $\mathcal{N}(K)$  is a subalgebra of  $\mathbb{G}$ . Indeed, using the Jacobi identity we have,  $\forall x, y \in \mathcal{N}(K)$ ,

$$[K, [x, y]] = -[x, [y, K]] - [y, [K, x]] \in K , \tag{1.2.18}$$

since in the r.h.s. the commutators  $[y, K]$  and  $[K, x]$  belong to  $K$  because of the definition Eq. (1.2.17), and so do then the double commutators.

A normalizer in the Lie algebra  $\mathbb{G}$  exponentiates to a normalizer in the Lie group  $G$ .

1.2.1.6 Centralizer

The centralizer  $\mathcal{C}(K)$  of a subspace  $K \subset \mathbb{G}$  is the subspace of  $\mathbb{G}$  for which  $K$  behaves like the centre:

$$\mathcal{C}(K) = \{x \in \mathbb{G} : [K, x] = 0\} . \tag{1.2.19}$$

The normalizer  $\mathcal{C}(K)$  is a subalgebra of  $\mathbb{G}$ . Indeed, using the Jacobi identity we have,  $\forall x, y \in \mathcal{C}(K)$ ,

$$[K, [x, y]] = -[x, [y, K]] - [y, [K, x]] = 0 , \tag{1.2.20}$$

as it follows from immediately using in the r.h.s. the Eq. (1.2.17), and so do then the double commutators.

A Lie algebra centralizer exponentiates to a centralizer in the Lie group  $G$ .

### 1.2.2 Quotient Lie algebras

The quotient space

$$\mathbb{G}/\mathcal{I} \tag{1.2.21}$$

of a Lie algebra  $\mathbb{G}$  by an ideal  $\mathcal{I} \subset \mathbb{G}$  is again a Lie algebra. In Eq. (1.2.21)  $\mathbb{G}/\mathcal{I}$ , as a vector space, is just the usual quotient space with respect to the equivalence relation

$$\forall x, x' \in \mathbb{G}, \quad x \sim x' \Leftrightarrow x' = x + u, \quad \text{for some } u \in \mathcal{I}. \tag{1.2.22}$$

The elements of  $\mathbb{G}/\mathcal{I}$  are the equivalence classes with respect to Eq. (1.2.22), which we may denote as  $[x] \equiv x + \mathcal{I}$ . The dimension of  $\mathbb{G}/\mathcal{I}$  is

$$\dim \mathbb{G}/\mathcal{I} = \dim \mathbb{G} - \dim \mathcal{I}. \tag{1.2.23}$$

The Lie product of the classes is simply defined as

$$[x + \mathcal{I}, y + \mathcal{I}] \equiv [x, y] + \mathcal{I}. \tag{1.2.24}$$

This is a good definition, namely it is independent of the choice of representatives  $x, y$  precisely because  $\mathcal{I}$  is in ideal. Indeed, choosing any other representatives  $x' = x + u$ ,  $y' = y + v$ , with  $u, v \in \mathcal{I}$ , we have

$$[x', y'] = [x + u, y + v] = [x, y] + w, \quad \text{with } w = [u, y] + [x, v] + [u, v] \in \mathcal{I}. \tag{1.2.25}$$

Therefore we find

$$[x' + \mathcal{I}, y' + \mathcal{I}] = [x, y] + \mathcal{I} = [x + \mathcal{I}, y + \mathcal{I}]. \tag{1.2.26}$$

Equipped with the Lie product Eq. (1.2.24) the quotient space is thus a Lie algebra.

Upon exponentiation, the quotient algebra gives rise to a factor group:

$$\mathbb{G}/\mathcal{I} \xrightarrow{\text{exp}} \exp(\mathbb{G}/\mathcal{I}) = G/I, \tag{1.2.27}$$

where  $I$  is the normal subgroup of  $G = \exp \mathbb{G}$  obtained exponentiating the ideal  $\mathcal{I}$ . Indeed, the equivalence relation Eq. (1.2.22) gives rise to the (left) equivalence relation in the group, see Eq. (??) which is used to define  $G/I$ : if  $x' \sim x$ , namely if  $x' = x + u$  for some  $u \in \mathcal{I}$ , then

$$e^{x+u} = e^x \exp\left(u - \frac{1}{2}[x, u] + \dots\right) = e^x h \quad \text{with } h' = e^{u'} \in I, \tag{1.2.28}$$

since  $u' \in \mathcal{I}$  as all the commutators in the exponent belong to  $\mathcal{I}$  by the definition of ideal. Thus the classes  $x + \mathcal{I}$  exponentiate to the classes  $e^x I$ , namely the elements of  $G/I$ . Since  $I$  is a normal subgroup,  $G/I$  is a group.

#### 1.2.2.1 First homomorphism theorem

The first homomorphism theorem for groups, discussed in Sec. ?? has a counterpart for Lie algebras. Let

$$\phi : \mathbb{G} \longrightarrow \mathbb{G}' \tag{1.2.29}$$

be a Lie algebra homomorphism.

i)  $\ker \phi$  is an ideal of  $\mathbb{G}$ . Indeed,  $\forall x \in \ker \phi, \forall y \in \mathbb{G}$ ,

$$\phi([x, y]) = [\phi(x), \phi(y)] = [0, \phi(y)] = 0, \tag{1.2.30}$$

so that  $[x, y]$  belongs to  $\ker \phi$  as well.

ii) We can thus form the quotient algebra  $\mathbb{G}/\ker \phi$ . When restricted to the quotient algebra,  $\phi$  becomes an isomorphism:

$$\phi : \mathbb{G}/\ker \phi \longleftrightarrow \mathbb{G}'. \tag{1.2.31}$$

The above is an example of the more general relation between homomorphisms (and isomorphisms) at the group and algebra level. The main idea (which we state without discussion) is the following. Let  $G_1, G_2$  be two Lie groups, and  $\mathbb{G}_1, \mathbb{G}_2$  their Lie algebras. In general, the group of group homomorphisms  $\text{Hom}(G_1, G_2)$  is mapped *homomorphically* onto the group of Lie algebra homomorphisms  $\text{hom}(\mathbb{G}_1, \mathbb{G}_2)$ . The map is an isomorphism only when  $G_1$  and  $G_2$  are simply-connected.

### 1.2.3 Adjoint action and adjoint map (or representation)

#### 1.2.3.1 Adjoint action of the group on the algebra

Every element  $g$  of a Lie group  $G$  determines an automorphism  $\text{Ad}_g$  of the associated Lie algebra  $\mathbb{G}$ , given as follows:

$$\forall x \in \mathbb{G}, \quad \text{Ad}_g : x \mapsto g^{-1}xg \in \mathbb{G}. \tag{1.2.32}$$

Indeed, writing  $g = e^y$ , with  $y \in \mathbb{G}$ , we see that

$$e^{-y}xe^y = x - [y, x] + \frac{1}{2}[y, [y, x]] + \dots \in \mathbb{G}. \tag{1.2.33}$$

The map  $\text{Ad}_g$  is an homomorphism since,  $\forall x, y \in \mathbb{G}$ ,

$$[g^{-1}xg, g^{-1}yg] = g^{-1}xgg^{-1}yg - (x \leftrightarrow y) = g^{-1}[x, y]g. \tag{1.2.34}$$

It is in fact also an isomorphism, as the kernel coincides with 0: asking that  $g^{-1}xg = 0$  implies that  $x = 0$ .

We made use of the adjoint action of the group in Sec. ?? when we discussed the homomorphic relation between  $\text{SU}(2)$  and  $\text{SO}(3)$ .

#### 1.2.3.2 The adjoint map (or adjoint representation) of a Lie algebra

The adjoint map  $\text{ad}$  associates to every element  $x$  in a Lie algebra  $\mathbb{G}$  a linear operator  $\text{ad}_x \in \text{End}(\mathbb{G})$  acting on  $\mathbb{G}$  itself, defined as follows:

$$\text{ad}_x : y \in \mathbb{G} \mapsto \text{ad}_x y = [x, y]. \tag{1.2.35}$$

This map is an homomorphism of the Lie algebra into itself, namely we have

$$[\text{ad}_x, \text{ad}_y] = \text{ad}_{[x, y]}, \tag{1.2.36}$$

where the commutator in the l.h.s. is a commutator of linear operators. Indeed,  $\forall z \in \mathbb{G}$ ,

$$\begin{aligned} [\text{ad}_x, \text{ad}_y]z &= \text{ad}_x [y, z] - \text{ad}_y [x, z] = [x, [y, z]] - [y, [x, z]] = -[x, [z, y]] - [y, [x, z]] \\ &= [z, [y, x]] = [x, [y, z]] = \text{ad}_{[x, y]}z. \end{aligned} \tag{1.2.37}$$

Thus the adjoint map gives in fact a  $d$ -dimensional representation of the Lie algebra  $\mathbb{G}$ , where  $d = \dim \mathbb{G}$ . The explicit matrix representatives can be written choosing a basis  $\{t_i\}$  of generators. One has then

$$\text{ad}_{t_i} t_j = [t_i, t_j] = c_{ij}^k t_k, \tag{1.2.38}$$

namely the generators in this representation are given by

$$(T_i)_j^k \equiv (\text{ad}_{t_i})_j^k = c_{ij}^k. \tag{1.2.39}$$

This is nothing else but the definition of the adjoint representation given in Sec. ??.

The kernel of the adjoint map is the center of the algebra:  $x \in \ker \text{ad}$  iff  $\text{ad}_x y = [x, y] = 0$  for every  $y \in \mathbb{G}$ , namely iff  $x \in Z(\mathbb{G})$ . Thus the adjoint representation is faithful only if  $\mathbb{G}$  has a trivial center.

### 1.2.3.3 Derivations of a Lie algebra

A derivation of a Lie algebra is an operator  $\partial : \mathbb{G} \rightarrow \mathbb{G}$  satisfying the following properties.

- i) Linearity:  $\partial(\alpha x + \beta y) = \alpha \partial x + \beta \partial y$ , where  $x, y \in \mathbb{G}$  and  $\alpha, \beta$  are scalar coefficients.
- ii) Leibnitz rule:

$$\partial [x, y] = [\partial x, y] + [x, \partial y]. \tag{1.2.40}$$

This concept is perfectly analogous to the concept of derivation of an algebra, discussed in the mathematical Appendix, Sec. ??, around Eq. (??), where we regarded tangent vectors and vector fields as derivations of the algebra of locally and globally defined functions respectively. We remarked that the space  $\partial \mathcal{A}$  of derivations of an algebra  $\mathcal{A}$  is a Lie algebra, see Eq. (??). The fact that the vector fields form a Lie algebra played an important role in our discussion of the relation between Lie groups and Lie algebras in Sec. ?. Similarly, the space  $\partial \mathbb{G}$  of derivations of a Lie algebra forms a Lie algebra. Show this directly as an exercise.

The adjoint operators  $\text{ad}_x$  are derivations of  $\mathbb{G}$ :  $\forall x \in \mathbb{G}, \text{ad}_x \in \mathbb{G}$  (so  $\partial \mathbb{G}$  is at least as big as  $\mathbb{G}$ ). Indeed, linearity is immediate, and the Leibnitz rule follows from the Jacobi identity:

$$\text{ad}_x [y, z] = [x, [y, z]] = -[y, [z, x]] - [z, [x, y]] = [[x, y], z] + [[y, x], z] = [\text{ad}_x y, z] + [y, \text{ad}_x z]. \tag{1.2.41}$$

## 1.2.4 Direct and semi-direct sums of Lie algebras

### 1.2.4.1 Direct sum of Lie algebras

We say that  $\mathbb{G}$  is the direct sum of  $\mathbb{G}_1$  and  $\mathbb{G}_2$ , and we denote it as

$$\mathbb{G} = \mathbb{G}_1 \oplus \mathbb{G}_2, \tag{1.2.42}$$

if the following is true:

- i)  $\mathbb{G}$  as a vector space is the direct sum of  $\mathbb{G}_1$  and  $\mathbb{G}_2$ ;
- ii)  $\mathbb{G}_1$  and  $\mathbb{G}_2$  are both ideals of  $\mathbb{G}$ :

$$\begin{aligned} [\mathbb{G}_1, \mathbb{G}_1 \oplus \mathbb{G}_2] &\subseteq \mathbb{G}_1, \\ [\mathbb{G}_2, \mathbb{G}_1 \oplus \mathbb{G}_2] &\subseteq \mathbb{G}_2 \end{aligned} \tag{1.2.43}$$

from which it follows that all the “mixed” commutators vanish:  $[\mathbb{G}_1, \mathbb{G}_2] = 0$ .

## 1.2.4.2 Semi-direct sum of Lie algebras

Let  $\mathbb{K}$  and  $\mathbb{H}$  be Lie algebras. Suppose that  $\mathbb{K}$  admits a representation  $\sigma$  by means of linear operators acting on  $\mathbb{H}$ :

$$\forall k \in \mathbb{K}, \quad \sigma : k \longrightarrow \sigma(k) \in \mathbb{H}. \quad (1.2.44)$$

Suppose moreover that all these operators  $\sigma(k)$  be derivations of  $\mathbb{H}$ . We define then the semi-direct sum Lie algebra

$$\mathbb{G} = \mathbb{K} \oplus_{\sigma} \mathbb{H} \quad (1.2.45)$$

as the Lie which

- i) as a vector space is simply the direct sum of  $\mathbb{K}$  and  $\mathbb{H}$ , so that its elements can be simply denoted as  $k + h$ , with  $k \in \mathbb{K}$  and  $h \in \mathbb{H}$ ;
- ii) is endowed with the Lie product

$$[k + h, k' + h'] \equiv [k, k'] + [h, h'] + \sigma(k)h' - \sigma(k')h. \quad (1.2.46)$$

Notice that the first term in the r.h.s. is in  $\mathbb{K}$ , all the remaining ones on  $\mathbb{H}$ . Eq. (1.2.46) is a good definition of a Lie product, as it satisfies the necessary properties: linearity and Jacobi identity. Linearity is immediate, Jacobi identity is left as an exercise (it is in verifying the Jacobi identity that the fact that  $\sigma(k)$  is a derivation comes into play).

In the reverse direction, when can we assert that a Lie algebra  $\mathbb{G}$  decomposes into a semidirect sum? It must be the case that  $\mathbb{G}$  decomposes as a vector space as  $\mathbb{G} = \mathbb{K} \oplus \mathbb{H}$  and

- i)  $\mathbb{K} \cap \mathbb{H} = 0$ , so that any element  $g \in \mathbb{G}$  is uniquely written as  $g = k + h$ , with  $k \in \mathbb{K}$  and  $h \in \mathbb{H}$ ;
- ii)  $\mathbb{H}$  is an ideal of  $\mathbb{G}$ .

This being the case, we have  $\mathbb{G} = \mathbb{K} \oplus_{\sigma} \mathbb{H}$ , with the original Lie product in  $\mathbb{G}$ . Indeed, we have

$$[k + h, k' + h'] = [k, k'] + [h, h'] + [k, h'] - [k', h] \quad (1.2.47)$$

which agrees with Eq. (1.2.46) with the representation  $\sigma$  of  $\mathbb{K}$  being provided by the adjoint map:  $\sigma(k) = \text{ad}_k$ . Indeed, since  $\mathbb{H}$  is an ideal, we have in particular  $[\mathbb{K}, \mathbb{H}] \subseteq \mathbb{H}$ , so that every  $\text{ad}_k$  is a linear operator acting on  $\mathbb{H}$

Under the exponential map, a semidirect sum maps to a semi-direct product of Lie groups:

$$\mathbb{G} = \mathbb{K} \oplus_{\sigma} \mathbb{H} \xrightarrow{\text{exp}} G = K \ltimes H, \quad (1.2.48)$$

where  $H = \exp \mathbb{H}$  is an invariant subgroup of  $G$ . The unicity of the decomposition at the algebra level maps into the unicity of the decomposition  $g \in G = \hat{g}\tilde{g}$ , with  $\hat{g} \in K$ ,  $\tilde{g} \in H$ , and the derivation  $\sigma$  defines upon exponentiation the ‘‘adjoint’’ action of  $K$  on  $H$  which is inherent to the definition of the semi-direct product of groups, see Eq. (??).

*Example of a direct sum Lie algebra:*  $\text{so}(4) \sim \text{so}(3) \oplus \text{so}(3)$  We defined in Eq. (??) a basis of generators  $L_{ab} = -L_{ba}$  ( $a < b$ ) for the  $\text{so}(n)$  algebra. The six  $\text{so}(4)$  generators  $L_{ab}$ , with  $a, b, = 1, 2, 3, 4$  satisfy the algebra Eq. (??), for  $n = 4$ :

$$[L_{ab}, L_{cd}] = \delta_{ad}L_{bc} + \delta_{bc}L_{ad} - \delta_{ac}L_{bd} - \delta_{bd}L_{ac}. \quad (1.2.49)$$



We can immediately individuate a  $\mathfrak{so}(3)$  subalgebra spanned by the three generators  $L_{ij}$ , where  $i, j$  run only up to 3. Viewing the  $L_{ab}$  as  $4 \times 4$  matrices, the  $L_{ij}$  are nothing else but the usual  $3 \times 3$  generators of  $\mathfrak{so}(3)$  placed in the upper left  $3 \times 3$  block. As usual for  $\mathfrak{so}(3)$  let us rename these generators as

$$M_i = \frac{1}{2} \epsilon_{ijk} L_{jk} \quad (i, j = 1, 2, 3). \quad (1.2.50)$$

These generators close evidently a  $\mathfrak{so}(3)$  subalgebra:

$$[M_i, M_j] = \epsilon_{ijk} M_k. \quad (1.2.51)$$

The remaining set of three generators we denote as follows:

$$N_i = L_{i4} \quad (i = 1, 2, 3). \quad (1.2.52)$$

From Eq. (1.2.49), beside Eq. (1.2.52), the following commutation relations arise (check it):

$$\begin{aligned} [N_i, N_j] &= -\epsilon_{ijk} M_k; \\ [M_i, N_j] &= \epsilon_{ijk} N_k. \end{aligned} \quad (1.2.53)$$

With the following *real* change of basis:

$$\begin{aligned} J_i &= \frac{M_i + N_i}{2}, \\ K_i &= \frac{M_i - N_i}{2}, \end{aligned} \quad (1.2.54)$$

it is possible to disentangle the commutation relations Eq.s (1.2.52,1.2.53); the Lie algebra  $\mathfrak{so}(4)$ , expressed in the basis of generators  $J_i, K_i$ , exhibits a direct product structure (check it):

$$\begin{aligned} [J_i, J_j] &= \epsilon_{ijk} J_k; \\ [K_i, K_j] &= \epsilon_{ijk} K_k. \end{aligned} \quad (1.2.55)$$

thus we have  $\mathfrak{so}(4) = \mathfrak{so}(3) \oplus \mathfrak{so}(3)$ , the two  $\mathfrak{so}(3)$  factors being generated respectively from the  $m_a$  and the  $N_a$ .

### 1.3 The main types of Lie algebras

The basic insight in trying to study and classify the possible Lie algebras is to analyze first their possible structure of ideals; as we have seen, when non-trivial ideals are present, this indicates that the algebra can be seen as being obtained as an “extension” by means e.g. of direct or semidirect sums from simpler algebras.

Let us start from some definitions that are appropriate to this task.

#### 1.3.1 Simple Lie algebras

A Lie algebra  $\mathbb{G}$  is *simple* iff

- i)  $\mathbb{G}$  admits no ideals;
- ii) the derived algebra  $D\mathbb{G} \equiv [\mathbb{G}, \mathbb{G}]$  is non trivial.

The requirement ii) excludes the Abelian algebras from the class of simple Lie algebras, which by requirement i) are defined indeed as the “simplest” Lie algebras, not admitting any substructure from which they could be determined as direct or semi-direct extensions.

Notice that if  $\mathbb{G}$  is simple, then

$$D\mathbb{G} = \mathbb{G} \tag{1.3.56}$$

as otherwise  $\mathbb{G}$  would contain a proper ideal  $D\mathbb{G}$ . Also, if  $\mathbb{G}$  is simple, its center  $Z(\mathbb{G})$  must be trivial, for the same reason.

The exponential of a simple Lie algebra  $\mathbb{G}$  gives a simple group  $G = \exp \mathbb{G}$  (if with  $G$  we denote the unique simply-connected group obtained upon exponentiation).

### 1.3.2 Nilpotent and solvable algebras

Simple Lie algebra have the property Eq. (1.3.56) that the derived algebra coincides with the algebra, namely that all elements can be expressed as commutators. We now introduce classes of algebras (nilpotent and solvable Lie algebras) that have in a way the opposite behaviour. The concepts of nilpotent and solvable algebras, and the contrasting one of semi-simple algebras we will introduce after, are basically extensions to entire Lie algebras of well known concepts for endomorphisms, that are very briefly summarized in Sec. ?? of the appendix.

#### 1.3.2.1 Nilpotent Lie algebras

A Lie algebra  $\mathbb{G}$  is a nilpotent Lie algebra if it possesses a terminating *central descending series* of ideals:

$$\mathbb{G} \equiv \mathbb{G}^1 \supset \mathbb{G}^2 \equiv [\mathbb{G}^1, \mathbb{G}^1] \supset \mathbb{G}^3 \equiv [\mathbb{G}^1, \mathbb{G}^2] \supset \dots \supset \mathbb{G}^k = \{0\}, \tag{1.3.57}$$

for some  $k \in \mathbb{N}$ .

The typical example of a nilpotent Lie algebra is the Lie algebra  $\mathfrak{N}(k, \mathbb{R})$  of strictly upper triangular  $N \times N$  matrices:  $\forall m \in \mathfrak{N}(N, \mathbb{R}), m_{ij} \neq 0 \Rightarrow j > i$ . It is then clear that in the product of any such matrices (and thus also in their commutator) also all the elements immediatly above the diagonal vanish:  $(mn)_{ij} \neq 0 \Rightarrow j > i + 1$ , and so on. Thus the subspaces of matrices  $\mathfrak{N}^i(k, \mathbb{R})$  which are non-zero only from  $i$  lines above the diagonal on form a terminating chain of ideals as in Eq. (1.3.57) with  $k = N$ , since

$$[\mathfrak{N}(N, \mathbb{R}), \mathfrak{N}^i(N, \mathbb{R})] = \mathfrak{N}^{i+1}(N, \mathbb{R}) \tag{1.3.58}$$

and clearly  $\mathfrak{N}^N(N, \mathbb{R})$  contains only the null matrix.

Notice however that it is *not* necessary that  $\mathbb{G}$  to be made of nilpotent operators for it to be a nilpotent algebra. Indeed, a simple counterexample is the Lie algebra of diagonal  $k \times k$  matrices,  $\mathfrak{D}(N, \mathbb{R})$  which is clearly Abelian (and isomorphic to  $\mathbb{R}^N$ ):

$$[\mathfrak{D}(N, \mathbb{R}), \mathfrak{D}(N, \mathbb{R})] = 0, \tag{1.3.59}$$

and thus exhibits the property Eq. (1.3.57) with  $k = 0$ .

The point is that the property Eq. (1.3.57) actually concerns the *adjoint* representation of the Lie algebra  $\mathbb{G}$ .

*Engel's theorem* Indeed, the definition Eq. (1.3.57) has the following meaning. For some  $k$ , that depends only on the algebra  $\mathbb{G}$ , we have

$$\text{ad}_{x_1} \text{ad}_{x_2} \dots \text{ad}_{x_k}(y) = 0 \quad \forall x_i, y \in \mathbb{G}. \quad (1.3.60)$$

In particular, as an operator,

$$(\text{ad}_x)^k = 0 \quad \forall x \in \mathbb{G}, \quad (1.3.61)$$

that is, all the *adjoint* operators  $\text{ad}_x$  are nilpotent endomorphisms, The converse (if all the adjoint operators  $\text{ad}_x$  are nilpotent then the algebra  $\mathbb{G}$  has the property Eq. (1.3.57)) turns also out to be true, so we have the so-called Engel's theorem:

$$\mathbb{G} \text{ nilpotent} \Leftrightarrow \forall x \in \mathbb{G}, \text{ad}_x \in \text{End}(\mathbb{G}) \text{ is nilpotent.} \quad (1.3.62)$$

*The chain property* Being nilpotent, all operators  $\text{ad}_x$  admit a common null eigenvector, and with an appropriate choice of basis  $\{t_i\}$  of  $\mathbb{G}$  they are represented by strictly upper triangular matrices. In this basis,  $\mathbb{G}$  admits a *chain of ideals* of codimension 1:

$$\mathbb{G}^1 \equiv \mathbb{G} \supset \mathbb{G}^2 \supset \dots \supset \mathbb{G}^d = \{0\}, \quad (1.3.63)$$

where  $d = \dim \mathbb{G}$ ,  $\mathbb{G} = \mathbb{G}^1$  is spanned by the generators  $\{t_i\}$ , with  $i = 1, \dots, d$ ,  $\mathbb{G}^2$  is spanned by  $\{t_i\}$  with  $i = 1, \dots, d - 1$  and so forth. We have  $\dim \mathbb{G}^n = d - n - 1$  and (by the same reasoning we used to obtain Eq. (1.3.58))

$$\forall x \in \mathbb{G}, \text{ad}_x : \mathbb{G}^k \longrightarrow \mathbb{G}^{k+1}, \text{ i.e., } [\mathbb{G}, \mathbb{G}^k] \subset \mathbb{G}^{k+1}. \quad (1.3.64)$$

The chain of ideals Eq. (1.3.63) “majorizes” the central descending series Eq. (1.3.57).

#### *Some properties of nilpotent Lie algebras*

- i) If  $\mathbb{G}$  is nilpotent, all subalgebras and homomorphic images of  $\mathbb{G}$  are nilpotent as well.
- ii) If  $\mathbb{G}/Z$  ( $\mathbb{G}$  is nilpotent, then  $\mathbb{G}$  is nilpotent (show this as an exercise).
- iii) If  $\mathbb{G}$  is nilpotent (and non-trivial), then it has a non-trivial center. Indeed, the last term in the central descending series Eq. (1.3.57) is central:  $[\mathbb{G}, \mathbb{G}^{k-1}] = 0$ .

#### *1.3.2.2 Solvable Lie algebras*

Nilpotent algebras are defined by the property Eq. (1.3.57). We have seen that this implies the chain property Eq. (1.3.63), but is in fact a stronger condition the reverse implication does not hold).

Now we extend our attention to the most general Lie algebras that admit a chain of codimension 1 ideals as in Eq. (1.3.63) (or, briefly. “have the chain property”). Such algebras are named *solvable* Lie algebras.

The name is due to the fact that under the exponential map, a solvable Lie algebra gives rise to a solvable Lie group. Indeed, referring to the chain Eq. (1.3.63), the quotient algebra  $\mathbb{G}^k/\mathbb{G}^{k+1}$  has dimension 1, hence it is Abelian. For the Lie group  $G = \exp \mathbb{G}$  we obtain a chain of invariant subgroups:

$$G^1 \equiv G \supset G^2 \supset \dots \supset G^d = \{e\} \quad (1.3.65)$$

with all the factor groups  $G^k/G^{k+1}$  having dimension 1, and hence being Abelian. According to the definition given in Sec. ??,  $G$  is solvable.

It is possible to define the solvability in a different way, by means of a property similar to (but less restrictive than) the property Eq. (1.3.57) that defines the nilpotent algebras. An algebra  $\mathbb{G}$  is solvable iff it possesses a *terminating derivative series*:

$$\mathbb{G} \supset D\mathbb{G} \supset D^2\mathbb{G} \supset \dots \supset D^k\mathbb{G} = \{0\}, \tag{1.3.66}$$

for some  $k \in \mathbb{N}$ . The properties Eq. (1.3.65) and Eq. (1.3.66) are equivalent. Assume Eq. (1.3.65). Since  $\mathbb{G}$  admits a proper ideal  $\mathbb{G}^2$ , it can be shown that  $D\mathbb{G} \neq \mathbb{G}$ : the algebra is not simple. The dimension of  $D\mathbb{G}$  must therefore be at least 1 less than the dimension of  $\mathbb{G}$ , so  $D\mathbb{G} \subseteq \mathbb{G}^2$ . The reasoning can be repeated for  $\mathbb{G}^2$ , which admits the proper ideal  $\mathbb{G}^3$ , so that  $D\mathbb{G}^2 = D^2\mathbb{G} \subseteq \mathbb{G}^3$ , and so on. Thus the chain Eq. (1.3.65) majorizes the derivative series Eq. (1.3.66); since the former stops at some point, so does the second. In the reverse direction, assume Eq. (1.3.66). Since  $D\mathbb{G} \subset \mathbb{G}$  is a proper ideal, there is a subset of generators of  $\mathbb{G}$ ,  $\{t_i\}$  with  $i = 1, \dots, p$ , which are outside  $D\mathbb{G}$ . Let us adjoin all these generators but one to  $D\mathbb{G}$ , namely let us construct  $\mathbb{G} \oplus \text{Span}(t_1, \dots, t_{p-1})$ . This subspace is an ideal since it contains  $D\mathbb{G}$ , and has codimension 1. The argument can be repeated, so that the series Eq. (1.3.65) can be constructed.

The solvable Lie algebras are characterized by the fact that

- i) all the adjoint operators  $\text{ad}_x, \forall x \in \mathbb{G}$  admit a common eigenvector (in general, a non-null one);
- ii) there exists a basis of  $\mathbb{G}$  in which all the matrices  $\text{ad}_x$  have an upper (not strictly upper, in general) triangular form. This is true at the level of complexified algebras, the change to such a basis is in general complex.

Some important properties of solvable algebras are listed below.

- i) If  $\mathbb{G}$  is solvable,  $D\mathbb{G}$  is nilpotent.
- ii) If  $\mathbb{G}$  is solvable, so are all its subalgebras and homomorphic images.
- iii) If  $\mathcal{I} \subset \mathbb{G}$  is a solvable ideal and  $\mathbb{G}/\mathcal{I}$  is solvable, then  $\mathbb{G}$  is solvable.
- iv) If  $\mathcal{I}$  and  $\mathcal{I}'$  are solvable ideals of some Lie algebra  $\mathbb{G}$ , then  $\mathcal{I} + \mathcal{I}'$  is a solvable ideal of  $\mathbb{G}$ .

The typical model of a solvable Lie algebra is the Lie algebra  $\mathfrak{M}(N, \mathbb{R})$  of  $N \times N$  upper triangular matrices:  $\forall m \in \mathfrak{M}(N, \mathbb{R}), m_{ij} \neq 0 \Leftrightarrow j \geq i$ . The product of two such matrices is still upper triangular, but any commutator  $[m, n]$  is strictly upper triangular (the terms on the diagonal cancel):

$$[\mathfrak{M}(N, \mathbb{R}), \mathfrak{M}(N, \mathbb{R})] = \mathfrak{N}(N, \mathbb{R}) \tag{1.3.67}$$

where  $\mathfrak{N}(N, \mathbb{R})$  is the *nilpotent* Lie algebra of strictly upper triangular matrices described after Eq. (1.3.57). The central descending series Eq. (1.3.57) for  $\mathfrak{M}(N, \mathbb{R})$  does not terminate, since if we now commute an element  $m$  of  $\mathfrak{M}(N, \mathbb{R}), m_{ij} \neq 0 \Leftrightarrow j \geq i$ , with a strictly upper triangular matrix  $n \in \mathfrak{N}(N, \mathbb{R}), n_{ij} \neq 0 \Leftrightarrow j > i$ , we get  $[m, n]_{ij} \neq 0 \Leftrightarrow j > i$ , i.e.

$$[\mathfrak{M}(N, \mathbb{R}), \mathfrak{N}(N, \mathbb{R})] = \mathfrak{N}(N, \mathbb{R}), \tag{1.3.68}$$

and the descending series does not proceed further. However, the derivative series Eq. (1.3.66) does terminate: the commutators of commutators become “more and more upper-triangular”.

*Example* A simple example of a solvable Lie algebra is given by the Lie algebra  $\text{iso}(2)$  of the inhomogeneous proper rotation group  $\text{ISO}(2)$ , that we discussed in Sec. ???. The group  $\text{ISO}(2)$  is the group of transformations of the space  $\mathbb{R}^2$  described by Eq. (??):  $\mathbf{x} \mapsto \mathcal{R}(\theta)\mathbf{x} + \mathbf{v}$ , where  $\mathcal{R}(\theta) \in \text{SO}(2)$  and  $\mathbf{x} \equiv (x^1, x^2) \in \mathbb{R}^2$ . It is a 3-dimensional Lie group, parametrized by the three

coordinates  $\theta \in [0, 2\pi]$  and  $v^i \in \mathbb{R}$ ,  $i = 1, 2$ . The generators of infinitesimal transformations  $T_1$  and  $T_2$ , associated to infinitesimal transformations  $\delta v^1$  and  $\delta v^2$  respectively, and  $T_3$ , associated to  $\delta\theta$ , accordingly to Eq. (??) are immediately found to be given by

$$T_1 = \frac{\partial}{\partial x^1}, \quad T_2 = \frac{\partial}{\partial x^2}, \quad T_3 = x^2 \frac{\partial}{\partial x^1} - x^1 \frac{\partial}{\partial x^2}. \quad (1.3.69)$$

$T_3$  is indeed ( $-i$  times) the angular momentum in the  $x^1, x^2$  plane, see Eq. (??), while  $T_{1,2}$  are ( $i$  times) the momenta in the two directions. Their commutators are easily found:

$$[T_1, T_2] = 0, \quad [T_3, T_1] = T_2, \quad [T_3, T_2] = -T_1. \quad (1.3.70)$$

The subalgebra spanned by  $T_{1,2}$  is just the algebra of infinitesimal two-dimensional translations  $\mathcal{T}_2 \sim \mathbb{R}^2$ , which is Abelian.

Changing basis by introducing  $T_{\pm} = T_2 \pm iT_1$ , the commutation relations become

$$[T_+, T_-] = 0, \quad [T_3, T_{\pm}] = \pm iT_{\pm}. \quad (1.3.71)$$

The commutations define the form of the adjoint endomorphisms:

$$\text{ad}_{T_i} T_j \equiv [T_i, T_j] = (\text{ad}_{T_i})_j^k T_k. \quad (1.3.72)$$

With the basis ordering  $(T_3, T_+, T_-)$  Eq. (1.3.71) implies thus

$$\text{ad}_{T_3} = \begin{pmatrix} 0 & 0 & 0 \\ 0 & i & 0 \\ 0 & 0 & i \end{pmatrix}, \quad \text{ad}_{T_+} = \begin{pmatrix} 0 & -i & 0 \\ 0 & 0 & 0 \\ 0 & 0 & 0 \end{pmatrix}, \quad \text{ad}_{T_-} = \begin{pmatrix} 0 & 0 & i \\ 0 & 0 & 0 \\ 0 & 0 & 0 \end{pmatrix}. \quad (1.3.73)$$

All the adjoint matrices are upper triangular. On the other hand, the algebra  $\text{iso}(2)$  is immediately seen to be solvable according to the definition Eq. (1.3.66). The central descending series is

$$\text{iso}(2) \supset \text{Diso}(2) \equiv [\text{iso}(2), \text{iso}(2)] = \mathcal{T}_2 \supset D^2 \text{iso}(2) \equiv [\mathcal{T}_2, \mathcal{T}_2] = 0. \quad (1.3.74)$$

Indeed, it follows from Eq. (1.3.69) that only the generators  $T_{1,2}$  are expressible as commutators, so  $\text{Diso}(2) = \mathcal{T}_2$ . However,  $\mathcal{T}_2$  is abelian, so the series stops at the second step.

### 1.3.3 Semi-simple Lie algebras and the Levi decomposition

#### 1.3.3.1 The radical of a Lie algebra

The radical of a Lie algebra  $\mathbb{G}$ , denoted as  $\text{Rad } \mathbb{G}$ , is the maximal solvable ideal of  $\mathbb{G}$ . Being maximal means that  $\text{Rad } \mathbb{G}$  is not strictly contained in any other solvable ideal.

The definition makes sense, because  $\text{Rad } \mathbb{G}$  is unique. Indeed, if  $\mathcal{S}$  is any other solvable ideal,  $\mathcal{S} + \text{Rad } \mathbb{G}$  is a solvable ideal. Since  $\text{Rad } \mathbb{G}$  is maximal, we must have  $\mathcal{S} + \text{Rad } \mathbb{G} = \text{Rad } \mathbb{G}$ . But this means that  $\mathcal{S} \subset \text{Rad } \mathbb{G}$ , so  $\text{Rad } \mathbb{G}$  contains all solvable ideals and is unique.

#### 1.3.3.2 Semi-simple Lie algebras

A semi-simple algebra is a Lie algebra that contains no solvable ideals:

$$\mathbb{G} \text{ semisimple} \Leftrightarrow \text{Rad } \mathbb{G} = \{0\}. \quad (1.3.75)$$

An equivalent definition is that

$$\mathbb{G} \text{ semisimple} \Leftrightarrow \mathbb{G} \text{ has no Abelian ideal.} \quad (1.3.76)$$

Indeed, if  $\mathbb{G}$  has an Abelian ideal  $\mathcal{A}$ , this ideal is of course also solvable (even nilpotent):  $[\mathcal{A}, \mathcal{A}] = 0$ . In the other direction, if  $\mathbb{G}$  admits a solvable ideal  $\mathcal{S}$ , then  $D^k \mathcal{S} = \{0\}$  for some  $k$ , namely  $[D^{k-1} \mathcal{S}, D^{k-1} \mathcal{S}] = \{0\}$ , i.e.,  $D^{k-1} \mathcal{S}$  is an Abelian ideal.

We see that with respect to the definition of simple Lie algebras in Sec. 1.3.1, the definition of semi-simple Lie algebras is much less restrictive: they can have ideals, only these ideals cannot be Abelian. What is the relation between semi-simple and simple Lie algebras? It turns out (we will not prove it here) that if  $\mathbb{G}$  is semi-simple, then generically it decomposes into a direct sum of simple Lie algebras:

$$\mathbb{G} = \oplus_i \mathbb{G}_i, \quad (1.3.77)$$

with  $\mathbb{G}_i$  simple.

An important observation is that for any Lie algebra  $\mathbb{G}$  the quotient algebra  $\mathbb{G}/\text{Rad } \mathbb{G}$  is semi-simple: we factor out the maximal solvable ideal, so that no solvable ideal remains. In fact, this statement can be made more precise, and we have the Levi's theorem.

### 1.3.3.3 Levi decomposition

Every Lie algebra  $\mathbb{G}$  can be written as

$$\mathbb{G} = \mathbb{L} \oplus_{\mathfrak{s}} \text{Rad } \mathbb{G}, \quad (1.3.78)$$

where the Lie algebra  $\mathbb{L}$ , called the Levi subalgebra of  $\mathbb{G}$ , is semi-simple.

*Example: the Galileian algebra* The invariance group of classical non relativistic mechanics is the *Galilei group* which consists of the following transformations on the space-time manifold whose points are labeled by the three space coordinates  $x^i$  and by the instant of time  $t$ :

$$\begin{pmatrix} x^i \\ t \end{pmatrix} \mapsto \begin{pmatrix} x^{i'} \\ t' \end{pmatrix} \quad (1.3.79)$$

where

$$\begin{cases} x^{i'} &= R^i_j x^j + v^i t + c^i \\ t' &= t + T \end{cases} \quad (1.3.80)$$

and

$$\begin{aligned} R^i_j &= \text{rotation matrix } RR^T = 1 \\ x^i &\mapsto x^i + c^i \text{ is a translation} \\ x^i &\mapsto x^i + v^i t \text{ corresponds to a special Galilei transformation} \\ t &\mapsto t + T \text{ corresponds to a time translation} \end{aligned} \quad (1.3.81)$$

The total number of parameters is 10 just as for the relativistic Poincaré group. Let us write the corresponding Lie algebra. For the rotations we have the *angular momentum* generators:

$$J_{ij} = x_i \partial_j - x_j \partial_i \quad \rightarrow \quad J_i = \epsilon_{ijk} x_j \partial_k \quad (1.3.82)$$

for the space translations we have the *momentum generators*

$$P_i = \partial_i \quad (1.3.83)$$

while the *galileian boosts* are generated by:

$$K_i = t \partial_i \tag{1.3.84}$$

Finally the *hamiltonian* generates time translations:

$$H = \partial_t \tag{1.3.85}$$

By explicit evaluation of the commutators we find that the Galilei Lie algebra has the following structure:

$$\begin{aligned} [J_i, J_j] &= \epsilon_{ijk} J_k & ; & & [J_i, P_j] &= -\epsilon_{ijk} P_k \\ [J_i, K_j] &= -\epsilon_{ijk} K_k & ; & & [J_i, H] &= 0 \\ [P_i, H] &= 0 & ; & & [P_i, P_j] &= 0 \\ [K_i, H] &= -P_i & ; & & [K_i, K_j] &= 0 \\ [P_i, K_j] &= 0 & & & & \end{aligned} \tag{1.3.86}$$

We can ask the question whether the Galilei algebra  $\mathbb{G}$  is *semisimple*. The answer is no. Indeed  $P_i$  ( $i = 1, 2, 3$ ) generate an abelian ideal since we easily verify that  $[P, X] \subset P, \forall X \in \mathbb{G}$ , so that  $P$  is an ideal. Next we inquiry whether  $\mathbb{G}$  is *solvable*. The derivative algebra  $D\mathbb{G}$  is made by  $J_i, P_i, K_i$ . We easily verify, however, that  $D^2\mathbb{G} = D\mathbb{G}$  so that  $\mathbb{G}$  is not solvable. On the other hand if we consider the subalgebra  $S^{(0)}$  generated by  $\{P, K, H\}$  we see that:

$$DS^{(0)} = S^{(1)} = \{P\} \quad ; \quad DS^{(1)} = \{0\} \tag{1.3.87}$$

so that  $S^{(0)}$  is solvable. The algebra generated by  $J_i$  is instead semisimple. Hence the Galilei algebra is, according to Levi's theorem, the direct product of a semisimple algebra with a solvable one.

### 1.3.4 The Killing form

The Killing form  $\kappa$  is a bilinear form on  $\mathbb{G}$ :

$$\kappa : \mathbb{G} \times \mathbb{G} \longrightarrow \mathbb{C}, \tag{1.3.88}$$

explicitly defined as follows:

$$\forall x, y \in \mathbb{G}, \quad \kappa(x, y) = \text{tr}(\text{ad}_x \text{ad}_y) . \tag{1.3.89}$$

It enjoys, beyond its bilinearity, which is immediate from Eq. (1.3.89), the following properties.

- i) It is symmetric:  $\kappa(x, y) = \kappa(y, x)$ , as follows immediately from the cyclic property of the trace.
- ii)  $\kappa([x, y], z) = \kappa(z, [y, z])$ . This follows from the homomorphicity of the ad map and the cyclicity of the trace. Indeed, ...

#### 1.3.4.1 The Killing metric

Being a bilinear form, the Killing form is determined by its value on any pair of basis vector of  $\mathbb{G}$ , namely by the *Killing metric*

$$\kappa_{ab} = \kappa(t_a, t_b) = \text{tr}(\text{ad}_{t_a} \text{ad}_{t_b}), \tag{1.3.90}$$

where  $\{t_a\}$  is a basis of generators. Expliciting the adjoint actions in Eq. (1.3.90), the Killing metric can be expressed in terms of the structure constants of the Lie algebra:

$$\kappa_{ab} = c_{ac}^d c_{bd}^c . \tag{1.3.91}$$

Indeed, ...

1.3.4.2 A completely antisymmetric tensor

The Killing metric can be used to “lower” the upper index of the structure constants, defining a tensor

$$c_{abc} = c_{ab}^f \kappa_{fc}. \tag{1.3.92}$$

The tensor  $c_{abc}$  is now totally *antisymmetric* with respect to the exchange of any indices. Indeed, ...

1.3.5 Cartan's criteria

The definition of solvable Lie algebras (and thus, of consequence, of semi-simple Lie algebras) refers to properties of the adjoint representation. Cartan has recast these definitions in terms of properties of traces in the adjoint representation, namely of properties of the Killing metric.

1.3.5.1 Cartan's criterion of solvability

$$\mathbb{G} \text{ solvable} \Leftrightarrow \forall x, y, z, \kappa(x, [y, z]) = 0. \tag{1.3.93}$$

This is the application of a trace criterion to establish the nilpotency of an endomorphism, applied in order to establish the nilpotency of  $D\mathbb{G}$ , and thus the solvability of  $\mathbb{G}$ .

1.3.5.2 Cartan's criterion of semi-simplicity

According to this criterion, a Lie algebra  $\mathbb{G}$  is semi-simple iff its Killing form is non-degenerate:

$$\mathbb{G} \text{ semi-simple} \Leftrightarrow \det(\kappa_{ab}) \neq 0. \tag{1.3.94}$$

*Example: the Killing form of su(2)* From the su(2) algebra Eq. (??) and

1.3.6 The Casimir operator

The 2-nd order Casimir operator  $C$  for a semi-simple Lie algebra is an operator quadratic in the generators, defined using the inverse of the Killing metric:

$$C = (\kappa^{-1})^{ab} t_a t_b. \tag{1.3.95}$$

it has the remarkable property of commuting with all generators:

$$[C, t_a] = 0, \quad \forall a = 1, \dots, \dim \mathbb{G}. \tag{1.3.96}$$

To prove this, ...

1.4 Cartan's canonical form of semi-simple Lie algebras

1.4.1 Cartan subalgebra and roots

...

1.4.1.1 Cartan decomposition and its properties

...



1.4.1.2 Canonical form of a semi-simple Lie algebra

...

Example:  $\mathfrak{sl}(2, \mathbb{C})$  ...

1.4.2 Properties of the root systems

Let us now consider the properties of a root system associated with a semisimple Lie algebra. We have the

*Theorem 1.4.1.* If  $\alpha, \beta \in \Phi$  are two roots, then the following two statements are true:

- (i)  $2 \frac{(\alpha, \beta)}{(\alpha, \alpha)} \in \mathbb{Z}$
- (ii)  $\beta - 2\alpha \frac{(\alpha, \beta)}{(\alpha, \alpha)} \in \Phi$  is also a root.

1.4.2.1 The Weyl group

...

1.4.2.2 Possible angles between the roots

It is convenient to introduce the following notation of a *hook product*

$$\langle \beta, \alpha \rangle \equiv 2 \frac{(\beta, \alpha)}{(\alpha, \alpha)} \tag{1.4.97}$$

From theorem 1.4.1 we have learned that  $\langle \beta, \alpha \rangle \in \mathbb{Z}$ , but at the same time also  $\langle \alpha, \beta \rangle \in \mathbb{Z}$ . Hence we conclude that

$$\langle \beta, \alpha \rangle \langle \alpha, \beta \rangle = 4 \cos^2 \theta_{\alpha\beta} \in \mathbb{Z} \tag{1.4.98}$$

where  $\theta_{\alpha\beta}$  is the angle between the two roots.

Explicitly, the table of possible ...

$\theta_{\alpha\beta}$	$\cos \theta_{\alpha\beta}$	$\cos^2 \theta_{\alpha\beta}$	$ \beta ^2/ \alpha ^2$	$\langle \alpha, \beta \rangle$	$\langle \beta, \alpha \rangle$
$\pi/6$	$\sqrt{3}/2$	$3/4$	3	1	3
$\pi/4$	$\sqrt{2}/2$	$1/2$	2	1	2
$\pi/3$	$1/2$	$1/4$	1	1	1
$\pi/2$	0	0	undet.	0	0
$2\pi/3$	$-1/2$	$1/4$	1	-1	-1
$3\pi/4$	$-\sqrt{2}/2$	$1/2$	2	-1	-2
$5\pi/6$	$-\sqrt{3}/2$	$3/4$	3	-1	-3

**Table 1.1.** Possible angles and ratio of norms between pairs of roots.

1.4.2.3 Root systems in rank 1 and 2

...

### 1.4.3 Simple root systems and the Cartan matrix

...

#### 1.4.3.1 Decomposable root systems

...

#### 1.4.3.2 Simple root systems

..

#### 1.4.3.3 The Cartan matrix

The Cartan matrix associated to a simple root system  $\Delta = \{\alpha_i\}$ ,  $i = 1, \dots, r$ , of a simple Lie algebra of rank  $r$  is defined by

$$C_{ij} = \langle \alpha_i, \alpha_j \rangle = 2 \frac{(\alpha_i, \alpha_j)}{(\alpha_j, \alpha_j)}. \quad (1.4.99)$$

According to Eq. (??), there are only the following possibilities

$$\begin{aligned} C_{ii} &= 2, \quad \forall i, \\ C_{ij} &= 0, -1, -2, -3, \quad \forall i \neq j. \end{aligned} \quad (1.4.100)$$

Notice that the Cartan matrix is in general not symmetric:  $\langle \alpha_i, \alpha_j \rangle \neq \langle \alpha_j, \alpha_i \rangle$  unless the two roots have the same length. So the Cartan matrix is symmetric only if all the simple roots have the same length (in which case the algebra is said to be a *simply-laced* Lie algebra).

*Example* For instance, consider the root system  $B_2$  of Fig. ???. We have  $\langle \alpha_1, \alpha_2 \rangle = -1$  and  $\langle \alpha_2, \alpha_1 \rangle = -2$ , so that the corresponding Cartan matrix is

$$C = \begin{pmatrix} 2 & -1 \\ -2 & 2 \end{pmatrix}. \quad (1.4.101)$$

*Example: the Lie algebra  $A_2 \sim \mathfrak{sl}(3, \mathbb{C})$  ...*

*Example: the  $G_2$  algebra ...*

### 1.4.4 Dynkin diagrams and the classification of simple Lie algebras

Having established that all possible irreducible root systems  $\Phi$  are uniquely determined (up to isomorphisms) by the Cartan matrix:

$$C_{ij} = \langle \alpha_i, \alpha_j \rangle \equiv 2 \frac{(\alpha_i, \alpha_j)}{(\alpha_j, \alpha_j)} \quad (1.4.102)$$

we can classify *all the complex simple Lie algebras* by classifying all possible Cartan matrices.

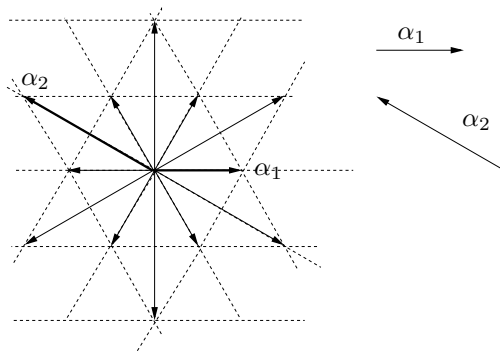

**Figure 1.1.** The root system  $G_2$ .

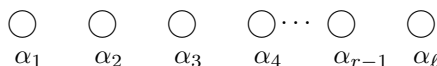

**Figure 1.2.** The simple roots  $\alpha_i$  are represented by circles

1.4.4.1 *Dynkin diagrams*

Each Cartan matrix can be given a graphical representation in the following way. To each simple root  $\alpha_i$  we associate a circle  $\bigcirc$  as in fig.1.2 and then we link the  $i$ -th circle with the  $j$ -th circle by means of a line which is *simple*, *double* or *triple* depending on whether

$$\langle \alpha_i, \alpha_j \rangle \langle \alpha_j, \alpha_i \rangle = 4 \cos^2 \theta_{ij} = \begin{cases} 1 \\ 2 \\ 3 \end{cases} \quad (1.4.103)$$

having denoted  $\theta_{ij}$  the angle between the two simple roots  $\alpha_i$  and  $\alpha_j$ . The corresponding graph is named a **Coxeter graph**.

If we consider the simplest case of two-dimensional Cartan matrices we have the four possible Coxeter graphs depicted in fig. 1.3 Given a Coxeter graph if it is *simply laced*, namely if there

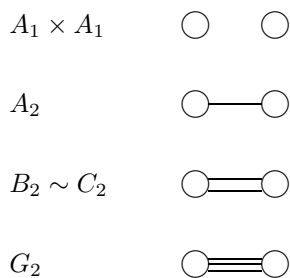

**Figure 1.3.** The four possible Coxeter graphs with two vertices

are only simple lines, then all the simple roots appearing in such a graph have the same *length* and the corresponding Cartan matrix is completely identified. On the other hand if the Coxeter

graph involves double or triple lines, then, in order to identify the corresponding Cartan matrix, we need to specify which of the two roots sitting at the end points of each multiple line is the *long* root and which is the *short* one. This can be done by associating an arrow to each multiple line. By convention we decide that this *arrow points* in the direction of the *short root*. A Coxeter graph equipped with the necessary arrows is named a **Dynkin diagram**. Applying this convention to the case of the Coxeter graphs of fig. 1.3 we obtain the result displayed in fig. 1.4. The one-to-one

$$\begin{array}{lll}
 A_1 \times A_1 & \circ \quad \circ & = \begin{pmatrix} 2 & 0 \\ 0 & 2 \end{pmatrix} \\
 A_2 & \circ \text{---} \circ & = \begin{pmatrix} 2 & -1 \\ -1 & 2 \end{pmatrix} \\
 B_2 & \circ \text{---} \Rightarrow \circ & = \begin{pmatrix} 2 & -2 \\ -1 & 2 \end{pmatrix} \\
 C_2 & \circ \text{---} \Leftarrow \circ & = \begin{pmatrix} 2 & -1 \\ -2 & 2 \end{pmatrix} \\
 G_2 & \circ \text{---} \Leftarrow \Leftarrow \circ & = \begin{pmatrix} 2 & -3 \\ -1 & 2 \end{pmatrix}
 \end{array}$$

**Figure 1.4.** The distinct Cartan matrices in two dimensions (and therefore the simple Algebras in rank two) correspond to the Dynkin diagrams displayed above. We have distinguished a  $B_2$  and a  $C_2$  matrix since they are the limiting case for  $\ell = 2$  of two series of Cartan matrices the  $B_\ell$  and the  $C_\ell$  series that for  $\ell > 2$  are truly different. However  $B_2$  is the transposed of  $C_2$  so that they correspond to isomorphic algebras obtained one from the other by renaming the two simple roots  $\alpha_1 \leftrightarrow \alpha_2$

correspondence between the Dynkin diagram and the associated Cartan matrix is illustrated by considering in some detail the case  $B_2$  of fig. 1.4. By definition of the Cartan matrix we have:

$$\begin{aligned}
 2 \frac{(\alpha_1, \alpha_2)}{(\alpha_2, \alpha_2)} &= 2 \frac{|\alpha_1|}{|\alpha_2|} \cos \theta = -2 \\
 2 \frac{(\alpha_2, \alpha_1)}{(\alpha_1, \alpha_1)} &= 2 \frac{|\alpha_2|}{|\alpha_1|} \cos \theta = -1
 \end{aligned} \tag{1.4.104}$$

so that we conclude:

$$|\alpha_1|^2 = 2|\alpha_2|^2 \tag{1.4.105}$$

which shows that  $\alpha_1$  is a long root, while  $\alpha_2$  is a short one. Hence the arrow in the Dynkin diagram pointing towards the short root  $\alpha_2$  tells us that the matrix elements  $C_{12}$  is  $-2$  while the matrix element  $C_{21}$  is  $-1$ . It happens the opposite in the example  $C_2$ .

#### 1.4.4.2 The classification theorem

Having clarified the notation of Dynkin diagrams the basic classification theorem of *complex simple Lie algebras* is the following:

*Theorem 1.4.2.* If  $\Phi$  is an irreducible system of roots of rank  $\ell$  then its Dynkin diagram is either one of those shown in fig.1.5 or for special values of  $\ell$  is one of those shown in fig.1.6. There are no other irreducible root systems besides these ones.

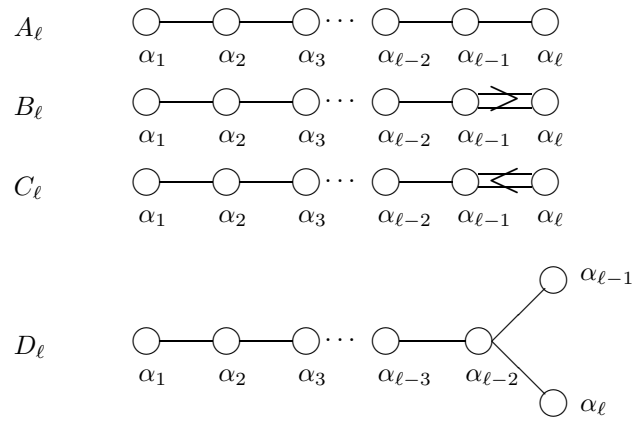

Figure 1.5. The Dynkin diagrams of the four infinite families of classical simple algebras

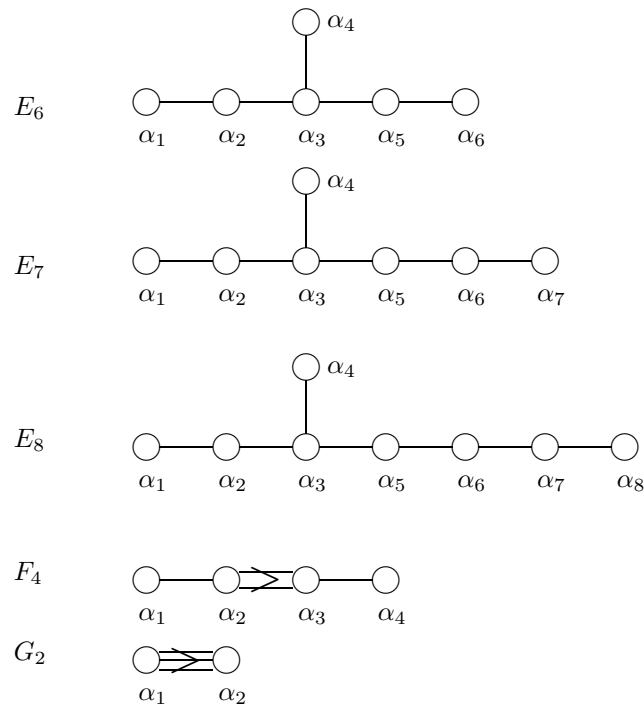

Figure 1.6. The Dynkin diagrams of the five exceptional algebras

### 1.4.5 The classical Lie algebras

The four families of simple Lie algebras  $A_r, B_r, C_r, D_r$  are named “classical Lie algebras” and represent the complexification of families of matrix Lie algebras, the rank  $r$  being related to the size of the matrices. Let us discuss some more details about these algebras and their root systems.

#### 1.4.5.1 The $A_r$ algebras

...

#### 1.4.5.2 The $B_r$ algebras

...

#### 1.4.5.3 The $C_r$ algebras

...

#### 1.4.5.4 The $D_r$ algebras

...